

# Industrial Shredders

Electric and Hydraulic Drives

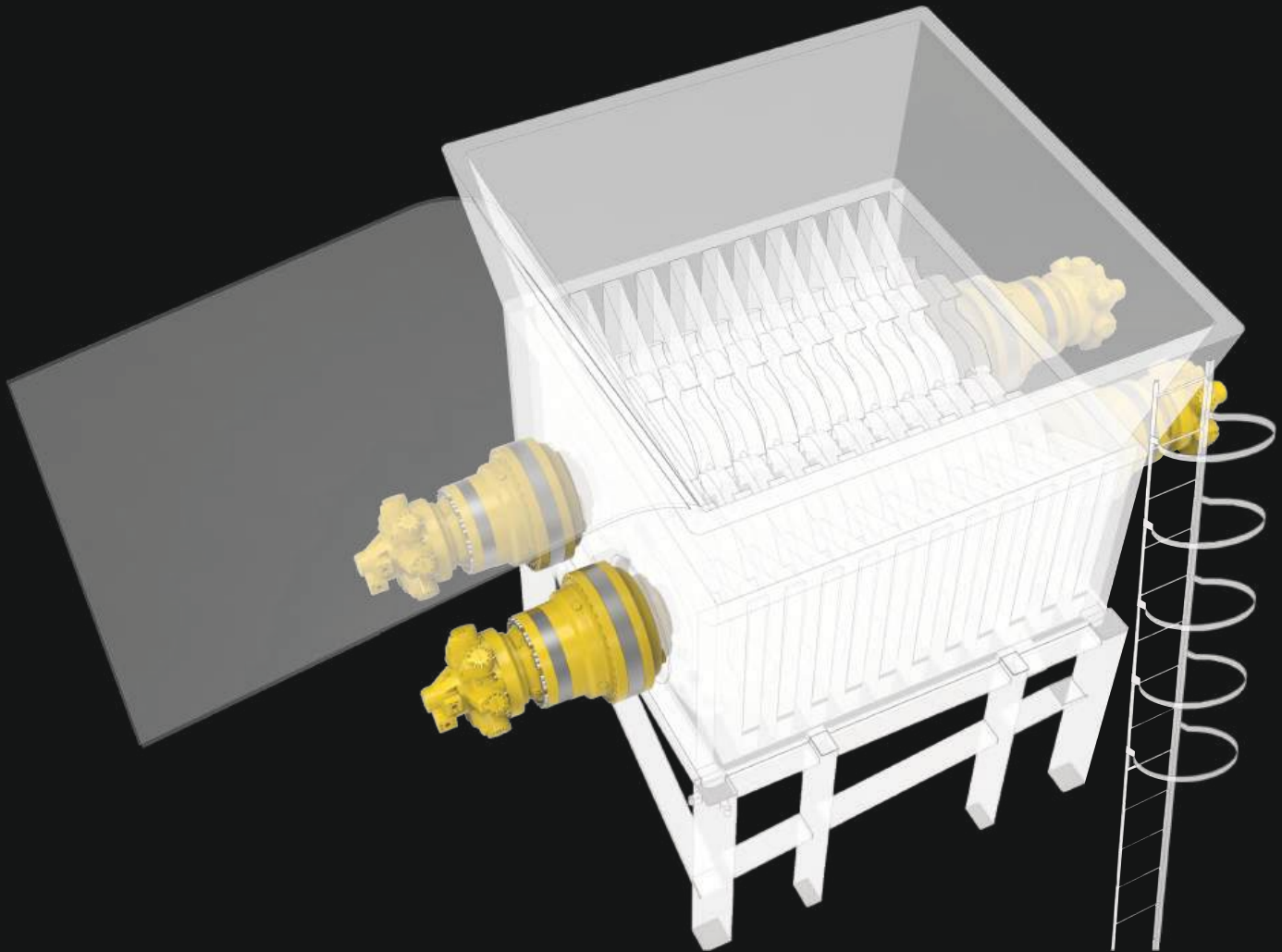

# BRANCHES

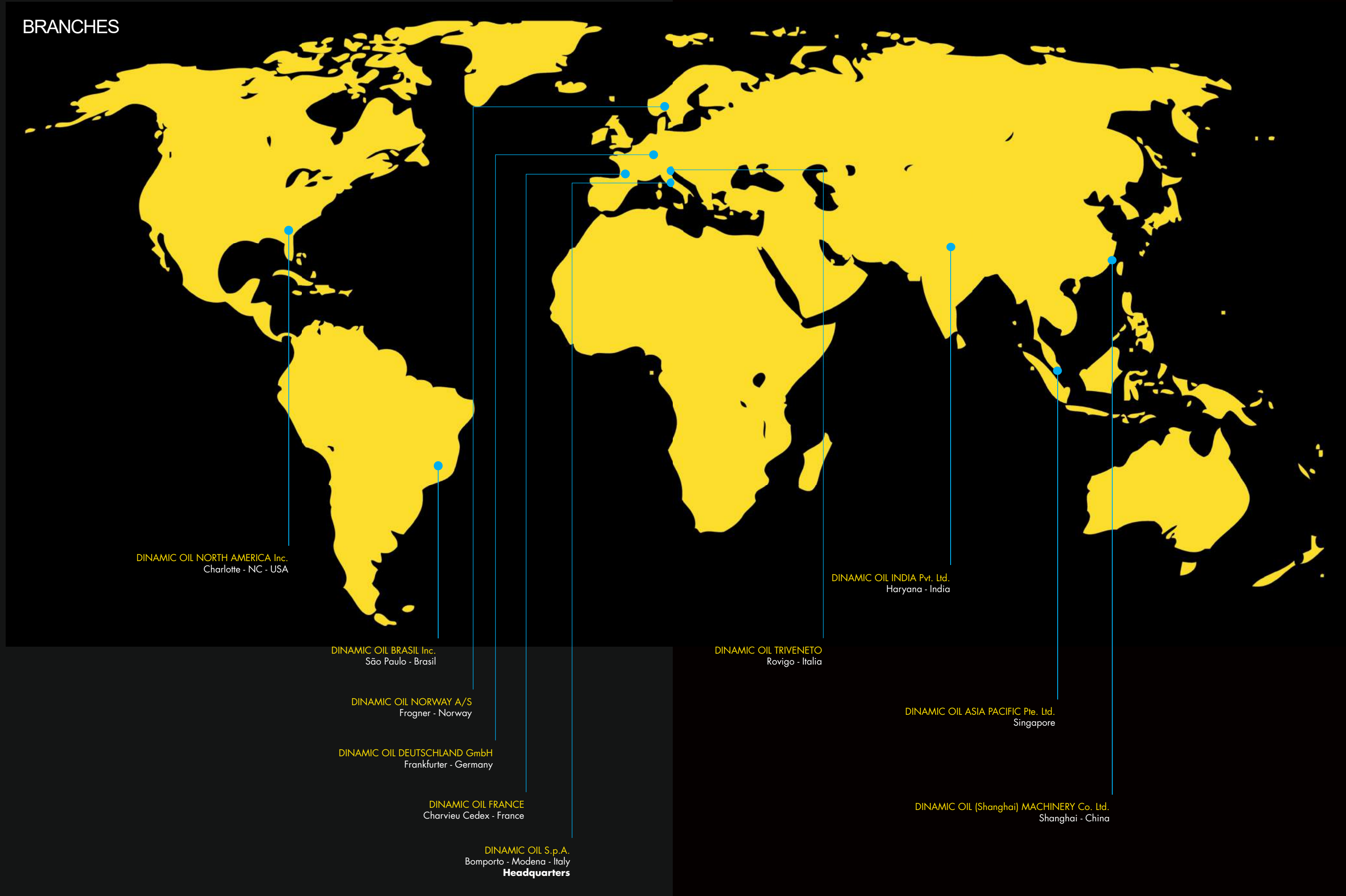

DINAMIC OIL NORTH AMERICA Inc.  
Charlotte - NC - USA

DINAMIC OIL BRASIL Inc.  
São Paulo - Brasil

DINAMIC OIL NORWAY A/S  
Frogner - Norway

DINAMIC OIL DEUTSCHLAND GmbH  
Frankfurter - Germany

DINAMIC OIL FRANCE  
Charvieu Cedex - France

DINAMIC OIL S.p.A.  
Bompoto - Modena - Italy  
**Headquarters**

DINAMIC OIL TRIVENETO  
Rovigo - Italia

DINAMIC OIL INDIA Pvt. Ltd.  
Haryana - India

DINAMIC OIL ASIA PACIFIC Pte. Ltd.  
Singapore

DINAMIC OIL (Shanghai) MACHINERY Co. Ltd.  
Shanghai - China

# INDUSTRIAL SHREDDERS

Material Separation & Volume Reduction

Great versatility, low energy consumption, and low level of noise and dust are the main advantages of low speed industrial shear shredders. The product to be shredded can go from bales to a consistent size waste product.

Dinamic Oil's planetary gearbox design is engineered to meet the demanding requirements of shredding applications, offering compatibility with multiple shaft geometries, drive interfaces, and drivetrain configurations catered to your application.

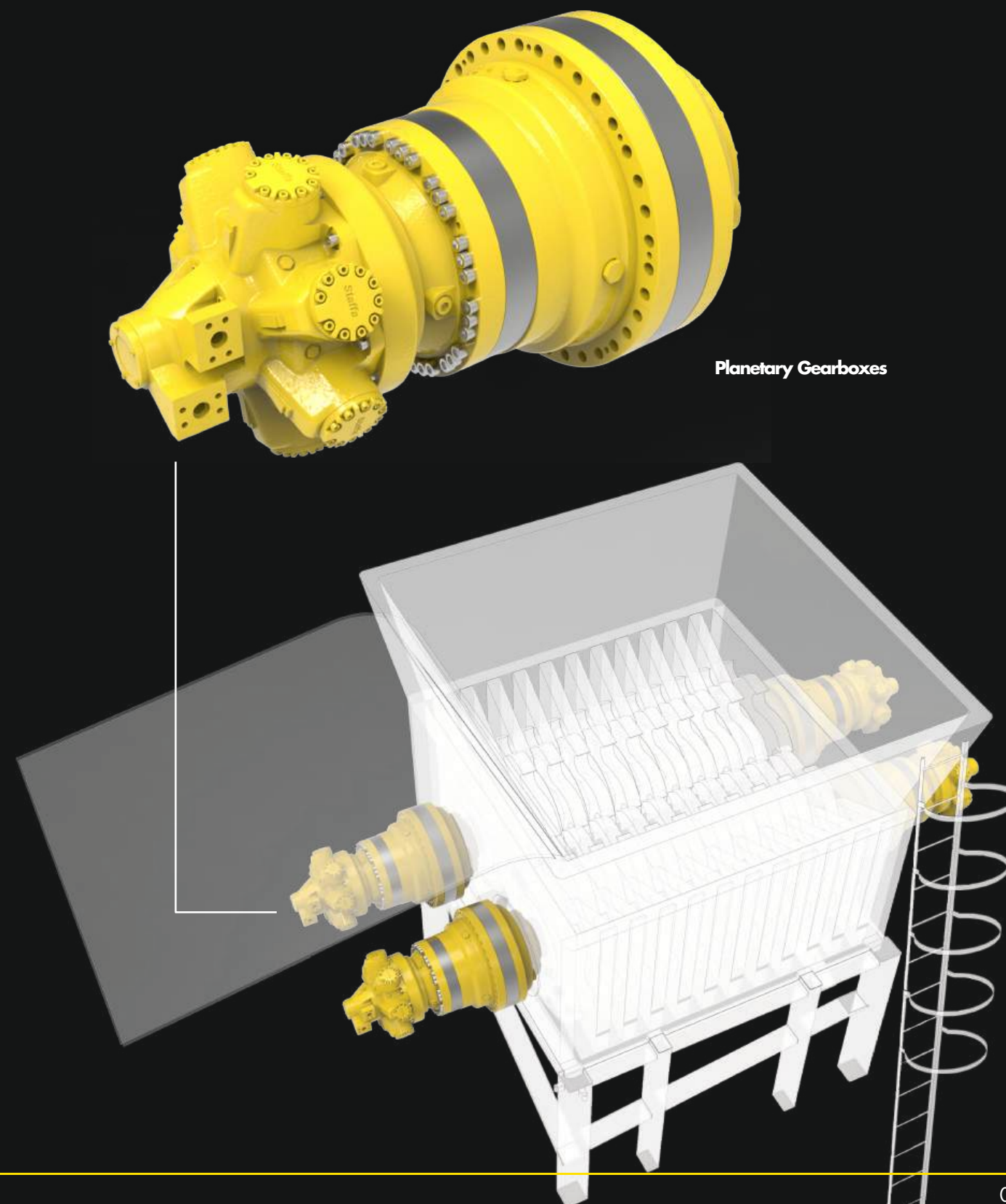



# RE SERIES

$T_{2max}$

## Torque Range

800 - 198,000 Nm  
7,000 - 1,752,447 in-lbs  
*Female-splined output ratings listed.*

i

## Ratio Range

3.48 - 3,164\*



RE	ie	RA	ie	$T_{2max}$ [Nm]
110	3.48-2153.35	110	11.14-1194.39	1780
210	3.48-2153.35	210	11.14-1194.39	3600
240	3.82-1658.88	240	12.22-900.53	4000
310	3.60-1990.66	310	10.03-1244.16	5630
510	3.60-1990.66	510	10.03-1244.16	11600
610	4.00-1416.08	610	11.14-629.37	14900
810	3.56-2264.19	810	10.41-1184.91	18600
1020	3.56-2264.19	1020	10.41-1184.91	27200
1520	4.09-2041.20	1520	12.56-1076.68	39000
2000	3.83-1451.52	2000	11.77-907.20	44100
2520	4.00-1925.49	2520	12.29-1091.91	50100
3000	4.00-1742.52	3000	12.29-968.07	78800
3510	3.84-2392.62	3510	12.48-1118.57	96500
4800	3.84-1741.68	4800	12.48-967.60	111000
6000	4.14-1435.91	6000	13.46-1009.38	135000
8000	4.00-3164.84	8000	13.00-800.00	198000



# GB SERIES

$T_{2max}$

## Torque Range

130,000 - 3,620,000 Nm  
1,150,596 - 32,039,699 in-lbs  
*Female-splined output ratings listed.*

i

## Ratio Range

4.09 - 3,554\*



GB	ie	GBA	ie	$T_{2max}$ [Nm]
12010	4.09-3544.35	12010	48.55-3161.48	281000
16000	3.83-3172.87	16000	47.84-3544.35	357000
21000	3.68-3129.84	21000	49.55-3065.78	406000
26000	3.68-3532.80	26000	55.81-2527.69	540000
31000	3.43-3559.02	31000	172.32-5011.04	650000
40000	3.43-3559.02	40000	172.32-5011.04	650000
45000	3.83-3554.59	45000	210.50-2211.75	650000
53000	3.84-3103.82	53000	248.00-4278.67	1191000
61000	3.84-2943.14	61000	190.27-11772.58	1131000
85000	3.84-2448.10	85000	214.32-11429.12	1131000
110000	4.32-3553.28	110000	744.42-21647.68	2250000
130000	4.32-2350.11	130000	909.34-10967.19	2720000
150000	4.07-2344.94			2720000
205000	4.14-3259.83			3620000
235000	4.14-2902.95			3620000

\*Standard ratios listed. Other ratio's may be available upon request.



# INPUTS\*

# OUTPUTS\*

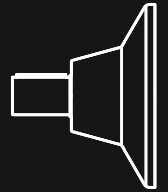
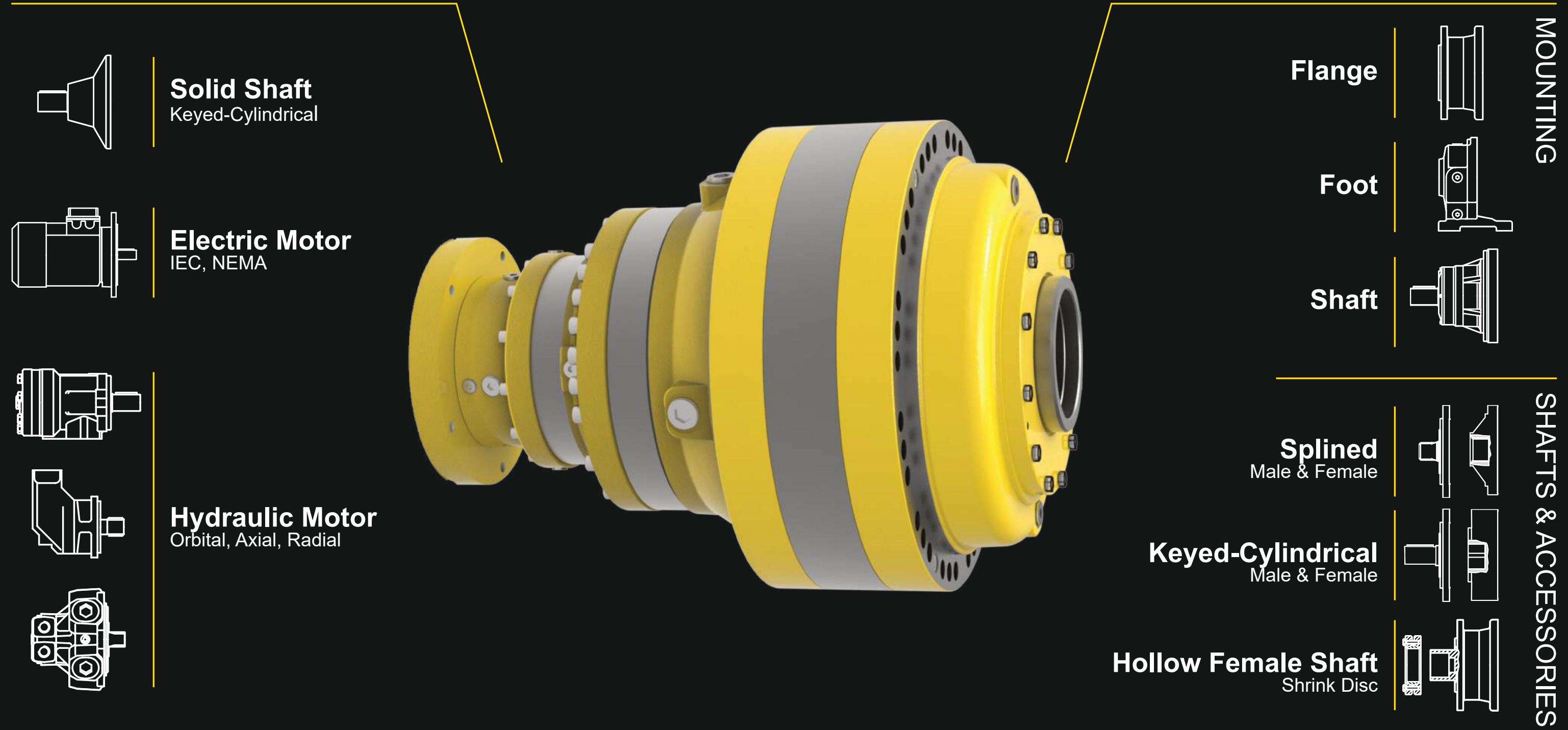

**Solid Shaft**  
Keyed-Cylindrical

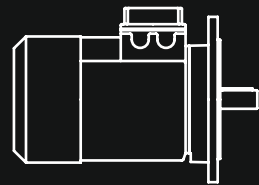

**Electric Motor**  
IEC, NEMA

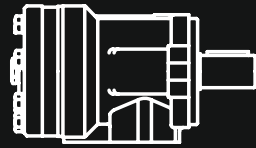

**Hydraulic Motor**  
Orbital, Axial, Radial

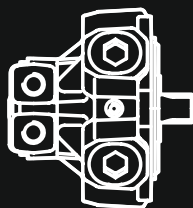
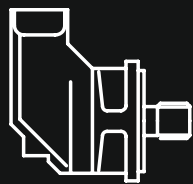

**Flange**

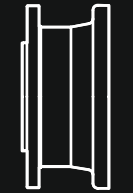

**Foot**

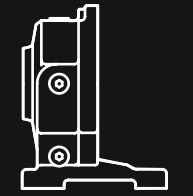

**Shaft**

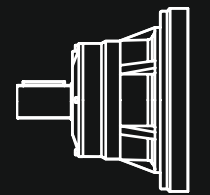

MOUNTING

**Splined**  
Male & Female

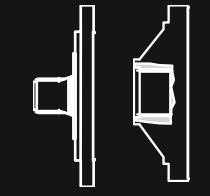

**Keyed-Cylindrical**  
Male & Female

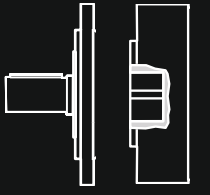

**Hollow Female Shaft**  
Shrink Disc

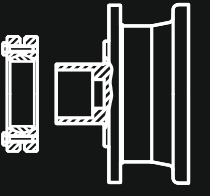

SHAFTS & ACCESSORIES

Torque-Arm



Pinion



Flange



Bushing



End-Plate



Splined-Bar



\*Customized solutions may be available upon request.

# OPTIONS\*



**Coatings\***  
C3, C4, C5  
RAL 9005 Black (Standard)



**Lubrication\***  
Expansion Tank  
Mechanical Oil Pump  
Sight-Glass Plug



**Sealing\***  
NBR  
VITON  
ROTO GLYD



**Thermal Devices\***  
Thermistor  
Water Jacket  
Thermocouple  
Fanned Input



**Modified Center Distance\***  
For Multi-Drive Shredders



# COOLING UNITS\*

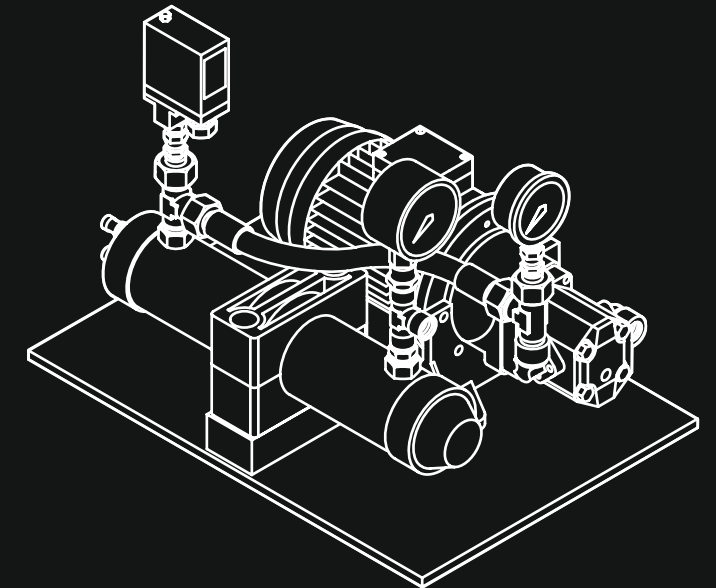

OIL / WATER

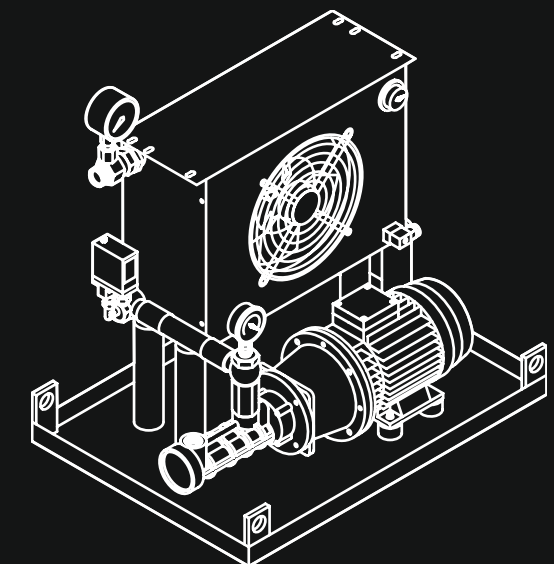

OIL / AIR

\*Customized solutions may be available upon request.

# “Catered to Your Application”

Great versatility from single-shaft  
to multi-shaft shredders,  
Dinamic Oil delivers  
Gearbox solutions that are  
catered to your application.

