

# Planetary Gearboxes

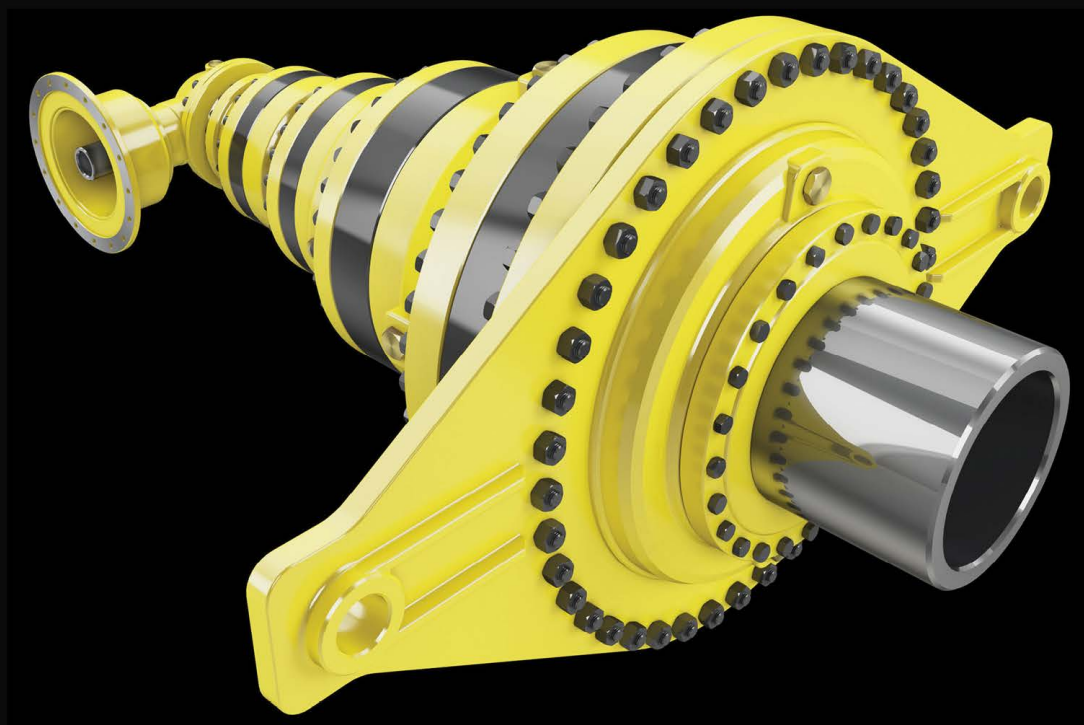

## RE / GB Series



**C7**

© 2020 Dinamic Oil S.P.A. All Rights Reserved

 **dinamic oil**

To meet the needs of an increasingly demanding and selective market Dinamic Oil have completely updated their RE and GB ranges of planetary gearboxes. With the introduction of new sizes the already comprehensive product lines have been extended and enhanced in line with feedback from the power transmission market.

Planetary gearboxes are suited to a broad range of applications covering the high overload characteristics found in the mobile industry to the longevity and reliability requirements of the industrial sector.

In the mobile market Dinamic Oil products can be found in machinery for lifting & transportation, building and construction, agriculture & marine; specific applications include concrete pumps, excavators, cranes and aerial platforms, in fact anywhere rotational movement is required. The use of planetary gearboxes for industrial applications is growing rapidly and they are now common in sheet metal, steel, plastics water treatment, chemical, energy mining and process industries.

The new 2012 catalogue facilitates quick & easy preliminary gearbox selection based on the transmissible power adjusted by the appropriate service factors. However, the Dinamic Oil Technical Sales Department is at your disposal providing a wealth of experience backed by the latest technology to provide confirmation and ensure the most cost effective solution in accordance with relevant standards.

The catalogue illustrates the range of gearboxes in production at the time of going to press with maximum torque capacity between 1000Nm and 3,000,000Nm. If your requirements fall outside this range please contact us.

The renowned versatility of Dinamic Oil gearboxes has been further expanded with the introduction of new input and output adaptors and accessories to make this the most comprehensive transmission system on the market

A large, white, stylized letter 'B' is positioned on the left side of the page, set against a black background. The letter is bold and has a modern, rounded design.

## Contents









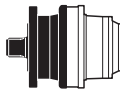
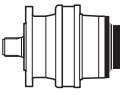
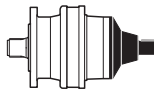

<b>1.0</b>	<b>Symbols and Unit of Measurement</b>	3
<b>2.0</b>	<b>Construction Options</b>	4
<b>3.0</b>	<b>Technical Definitions</b>	6
<b>4.0</b>	<b>Gearbox selection</b>	9
	4.1 Selection	9
	4.2 Verification	9
<b>5.0</b>	<b>Order Code</b>	10
<b>6.0</b>	<b>Negative Hydraulic Brakes</b>	12
	6.1 Negative Hydraulic Multi disk Brakes	12
	6.2 Brake Selection	12
<b>7.0</b>	<b>Assembly Positions</b>	12
<b>8.0</b>	<b>Installation Instructions</b>	13
	8.1 Installation	13
	8.2 Lubrication	14
	8.3 Paint	14
	8.4 Assembling Flanged Motors	14
	8.5 Assembling Motors with Connection Couplings	14
	8.6 Gearbox Weight	14
<b>9.0</b>	<b>Storage</b>	15
<b>10.0</b>	<b>Lubrication</b>	15
	10.1 Type of Lubrication	15
	10.2 Selecting an oil	15
	10.3 Changing the oil	15
	10.4 Oil quantity	15
	10.5 Recommended lubricants	16
	10.6 Temperature	16
<b>11.0</b>	<b>Independent Cooling Units</b>	17
	11.1 Independent oil/water cooling units, standard and customized composition (URO/W)	17
	11.2 Independent oil/air cooling units, standard and customized composition (URO/A)	18

## List of tables

<b>Table 1</b>	Service factors	6
<b>Table 2</b>	Thermal factors	7
<b>Table 3</b>	Values indicating durations required for different applications	8
<b>Table 4</b>	Torque and corresponding axial forces exerted by screws large pitch	14
<b>Table 5</b>	Recommended viscosity	16
<b>Table 6</b>	Recommended lubricants	16

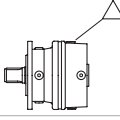
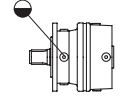
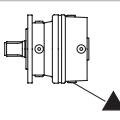
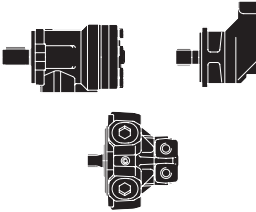
## 1.0 Symbols and Unit of Measurement

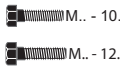
Symbol	Unit of measurement	Description
-1		Input value
-2		Output value
<b>bu</b>	mm	Height of toothed set
<b>de</b>	mm	External diameter
<b>dp</b>	mm	Theoretical primitive diameter
<b>fa</b>	N	Axial load
<b>f<sub>amax</sub></b>	N	Maximum axial load
<b>f<sub>r</sub></b>	N	Radial load
<b>H</b>	mm	Pinion height
<b>i<sub>e</sub></b>	-	Effective reduction ratio
<b>m</b>	mm	Module
<b>n</b>	RPM	Speed
<b>n<sub>max</sub></b>	RPM	Maximum speed
<b>nxh</b>	RPMxh	Duration index
<b>P<sub>1</sub></b>	kW	Rated power
<b>pb</b>	bar	Brake opening pressure
<b>pmax</b>	bar	Maximum brake pressure
<b>P<sub>t</sub></b>	kW	Thermal power
<b>T</b>	Nm	Torque
<b>T<sub>b</sub></b>	Nm	Braking torque
<b>T<sub>max</sub></b>	Nm	Maximum torque
<b>X</b>	mm	Load application distance
<b>x</b>	-	Tooth correction
<b>z</b>	-	Number of teeth

Symbol	Description
	Support at output
	Input
	Support at input
 ...Nm	Tightening torque [Nm]
	Oil quantity [liters]
	Weight [kg]
	Oil fill / breather plug
	Oil level
	Oil drain
	Hydraulic motors
	Electrical motors
	Wormgearbox
 M.. - 10.9  M.. - 12.9	Recommended screw
	Reference page

## 2.0 Construction Options

### USABLE MOTORS

- 1 Electric motor
- 2 Orbital hydraulic motor
- 3 Hydraulic motor with axial pistons
- 4 Hydraulic motor with radial pistons
- 5 Orbital hydraulic motor "MLR"

### TYPES OF INPUT

- 9 Preparation for motor connection
- 10 Input shaft
- 11 Direct electric motor adapter
- 12 Direct orbital motor adapter
- 13 Negative brake "F1../F2.."
- 14 Negative brake "F5../F6../F8../F9"
- 15 Standard flange
- 16 Adaptor "MZ"
- 17 Adaptor "MD"

### REDUCTION STAGES

- 18 Angular gearbox with direct input
- 19 One reduction stage
- 20 Two reduction stages
- 21 Three reduction stages
- 22 Four reduction stages
- 23 Five reduction stages

### SUPPORTS AND OUTPUT SHAFTS

- 24 Output support "N"
- 25 Output support "P"
- 26 Output support "T"
- 27 Output support "TR"
- 28 Output support "TL"
- 29 Output support "H"
- 30 Output support "F"
- 31 Output support "NQ"
- 32 Cylindrical output shaft
- 33 Splined output support
- 34 Female splined output shaft
- 35 Hexagonal output shaft
- 36 Female cylindrical output shaft

### ACCESSORIES

- 37 Pinion "P"
- 38 Flange "FL"
- 39 Splined bushing "BS"
- 40 Hexagonal bushing "ES"
- 41 Splined bar "BF"
- 42 Shrink disk "GA"
- 43 End plate "EP"
- 44 Oil expansion tank "VE"

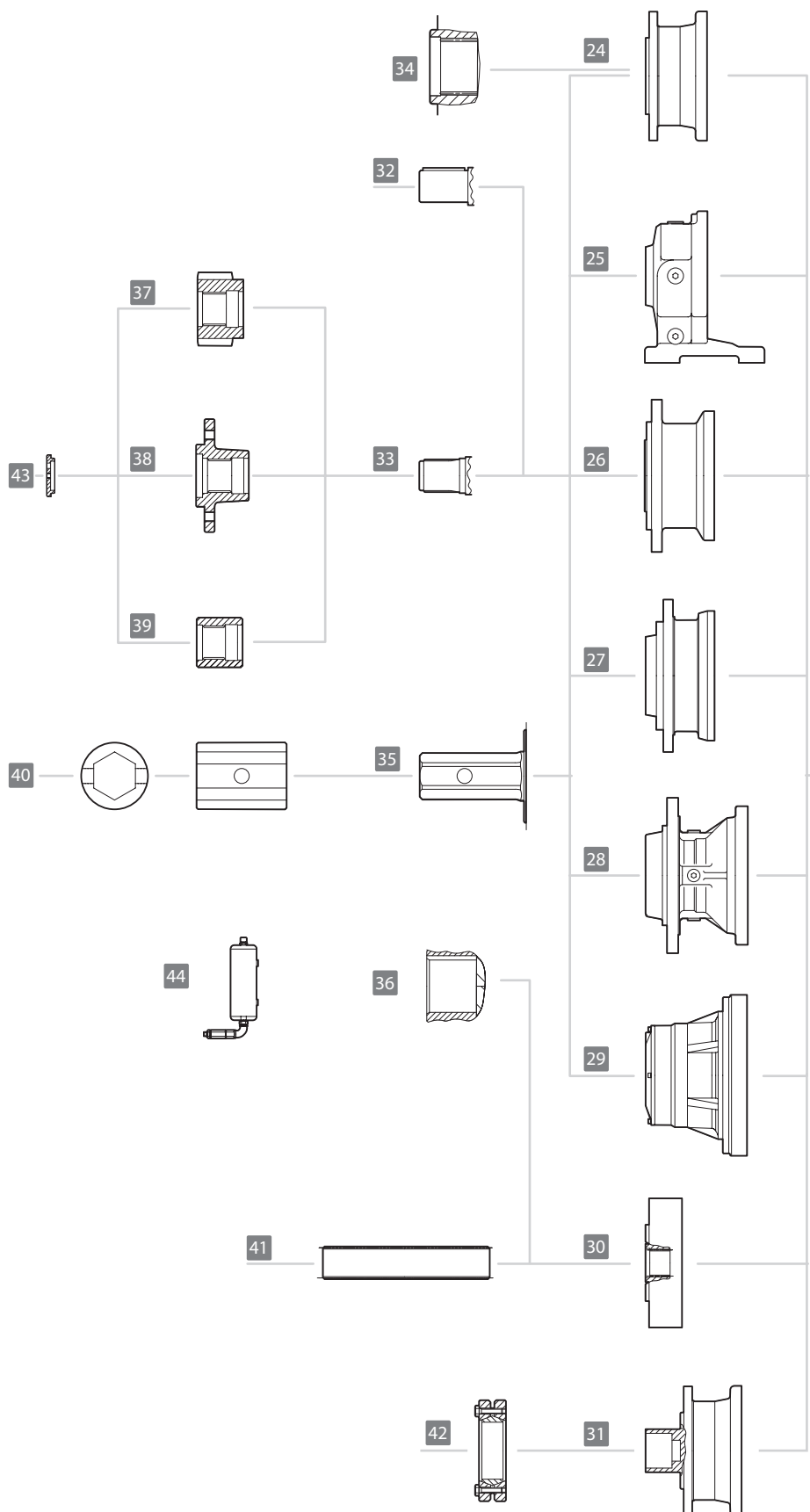

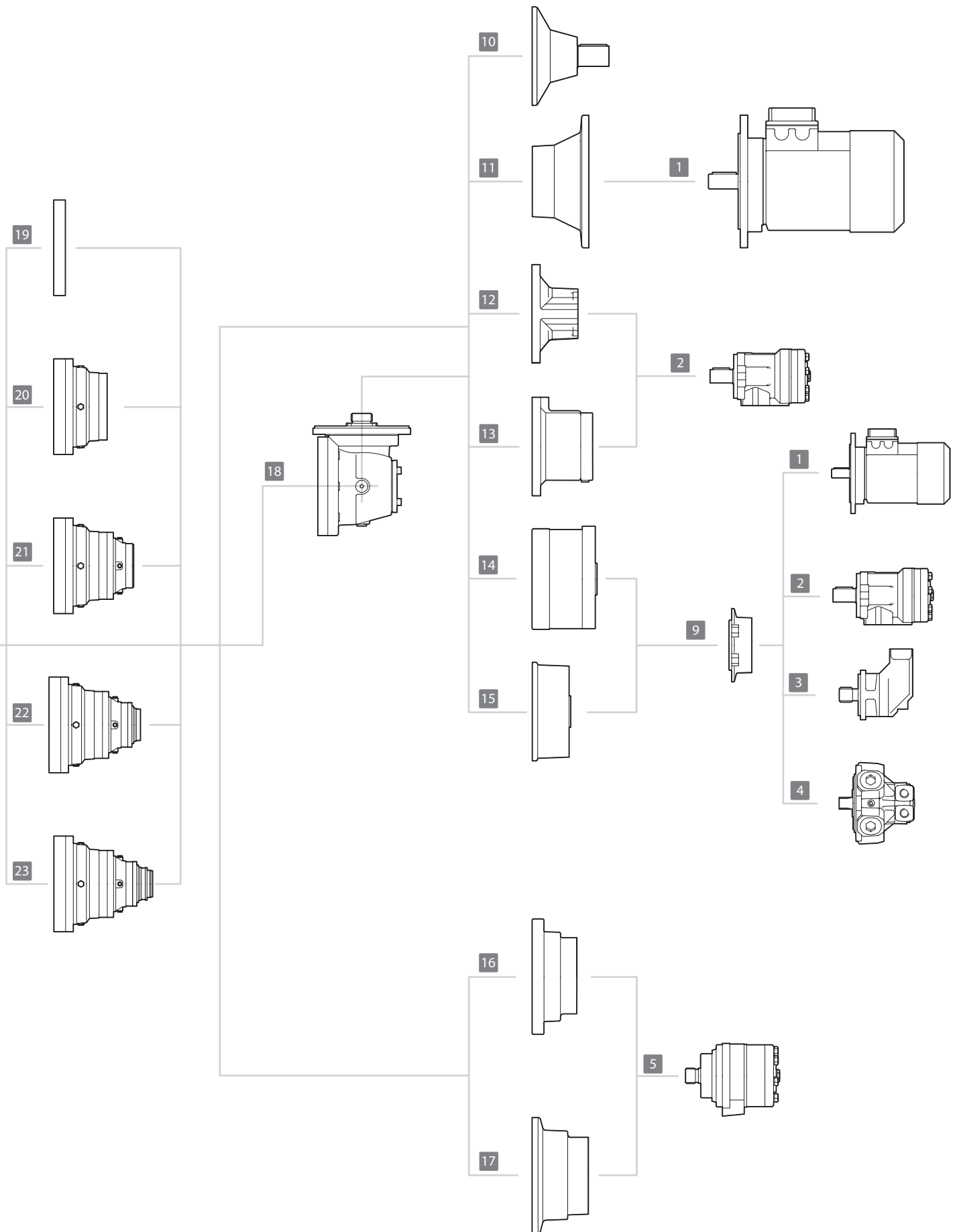

### 3.0 Technical Definitions

All values specified in this catalogue were calculated using the ISO 6336 and ISO 281 standards, but may not meet additional requirements set by the internal regulations of certifying bodies.

To select products that comply with these regulations, contact Dinamic Oil's sales team.

#### $f_s$ - Service Factor

this factor represents the application's industrial rating; it depends on operating conditions, type of drive and frequency of start-up.

The information provided in this catalog is calculated for  $f_s = 1$ . The service factor value of a gearbox may be calculated by dividing its nominal power by its absorbed power.

Service factors (tab. 1)

hours / day	OPERATING CONDITIONS								
	Uniform <b>U</b>			With moderate shocks <b>M</b>			With heavy shocks <b>H</b>		
	START-UPS / HOUR								
	< 16	16 - 63	64 - 250	< 16	16 - 63	64 - 250	< 16	16 - 63	64 - 250
< 0.5	0.9	1.3	1.5	0.9	1.3	1.5	1.2	1.5	1.8
0.5 - 3	0.9	1.3	1.5	1.2	1.5	1.8	1.7	2.0	2.3
3 - 8	1.2	1.5	1.8	1.4	1.8	2.0	1.9	2.3	2.8
8 - 24	1.4	1.8	2.0	1.7	2.0	2.5	2.4	2.8	3.0

#### $P_1$ - Nominal Power [kW]

the mechanical power transmitted by the gearbox, related to input. At  $f_s = 1$  the gearbox has a theoretical lifetime of 10000 hours under the ISO 6336 standard. This value does not take into account any limits on the gearbox's thermal capacity, as it is exclusively based on mechanical resistance in accordance with the speed of use.

#### $P_a$ - Absorbed Power [kW]

relates to installed or available power, the amount of power actually absorbed by the application, at the gearbox input

#### $P_t$ - Thermal Power [kW]

the maximum mechanical power the gearbox can transmit while in continuous operation, with splash lubrication, without going beyond its maximum temperature level (oil temperature below 90°C). More power may be transmitted using a Viton seal and synthetic oils or special cooling devices. The values indicated for various gearbox sizes refer to continuous operation with input speeds of 1500 RPM, at an ambient temperature of 20°C and an altitude of 0 / 500 m, for indoor applications.

Under different conditions of use, thermal power must be multiplied by the thermal factors identified in the tables below. For limited periods of operation, followed by periods of rest long enough to guarantee sufficient cooling of the gearbox, thermal power loses its significance and may be neglected.

**Thermal Factors (tab. 2)**

Ambient Temperature	Operating Time [%]				
	100%	80%	60%	40%	20%
10°	1.2	1.3	1.4	1.6	1.8
20°	1.0	1.1	1.3	1.4	1.6
30°	0.8	1.0	1.1	1.3	1.4
40°	0.7	0.8	1.0	1.1	1.3
50°	0.5	0.7	0.8	1.0	1.1

Altitude [m]	Input Speed [RPM]				
	400	800	1000	1500	2000
0	1.2	1.1	1.1	1.0	0.7
500	1.2	1.1	1.1	1.0	0.7
1000	1.1	1.0	1.0	0.9	0.6
1500	1.1	1.0	1.0	0.9	0.6
2000	1.1	1.0	1.0	0.9	0.6

**$P_d$  - Power to be Dissipated [kW]**

the power that a cooling system must dissipate if the power to be transmitted exceeds the gearbox's thermal power.

**$\eta_m$  - Mechanical Efficiency**

The ratio between mechanical power output and input; normally considered equal to 0.97 ÷ 0.98 for each epicycloidal reduction stage in the gearbox, and equal to 0.94 ÷ 0.95 for bevel gear; the actual value depends on a number of factors including speed, torque, ratio, assembly position and lubrication.

**$T_2$  - Torque Transmitted [Nm]**

this value represents torque continuously applied at a speed of  $n_1$ , at which the gearbox has a theoretical lifetime of 10000 h for gears, or 5000 h ( $L_{h10}$ ) for the bearings in gear mechanisms.

**$T_{max}$  - Maximum Transmissible torque [Nm]**

the maximum torque transmitted by the accessory supplied with the gearbox, if applicable. This value may limit the maximum transmissible torque of the gearbox.

**$T_{2max}$  - Maximum Torque [Nm]**

the maximum admissible output torque, as a peak value or for brief periods of time (calculated at 90% Rs of the weakest component).

For drives with a high number of start-ups or inversions, appropriately reduced maximum torque values should be considered.

The value specified refers to the version with a splined female shaft (FS); different versions may have lower values.

**$T_b$  - Braking Torque [Nm]**

the value of braking torque that may be conveyed statically by the negative brake.

**$n_1$  - Input Speed [RPM]**

the speed on the fast side of the gearbox.

**$n_2$  - Output Speed [RPM]**

the speed on the slow side of the gearbox.

**$n_{1max}$  - Maximum Speed [RPM]**

the maximum input speed at the brake. For applications with higher values, contact Dinamic Oil's sales service to determine application compatibility.

**$i_e$  - Effective Reduction Ratio**

the actual reduction ratio, meaning the ratio between the gearbox's input and output speeds.

**$n_xh$  - Duration Index [RPMxh]**

the value of the product between speed and duration of theoretical lifetime in hours. This value is expressed as  $n_2xh$  when used with output speed,  $n_1xh$  with used with input speed.

**Duration Values Required for Different Applications (tab. 3)**

Application	Required Lifetime
Agricultural machinery	300 - 3000
Machines operated intermittently or for short periods of time (construction machines)	3000 - 8000
Machines operated intermittently or for short periods of time with high operational reliability (freight lifts)	8000 - 12000
Machines operated 8 hours a day but not all the time (various industrial machines, rotary mills)	10000 - 25000
Machines operated 8 hours a day all the time (various industrial machines, conveyor belts)	20000 - 30000
Machines operated continuously (rolling mills, textiles machines)	40000 - 50000

**$k_f$  - Correction Factor**

the factor applied to calculate the theoretical lifetime of bearings with male shafts for values of  $n_xh$  other than those shown in catalog diagrams. External load curves are calculated for all gearboxes as:

- $n_2xh = 100000$  for output supports
- $n_1xh = 1500000$  for input supports

**$L_{min}$  - Minimum Length of Torque Arm [mm]**

the minimum length recommended for the torque arm, applied to pendular applications.

## 4.0 Gearbox selection

### 4.1 Selection

Gearbox selection is based on the service factor required by the application and the required output speed. Once the electric motor has been determined (in terms of nominal speed and power), select the gearbox with the reduction ratio required to reach the required output speed and nominal power needed to ensure that the ratio between its value and the value of the motor's rated power is higher than the service factor.

$$i_e = n_1 / n_2$$

$$P_1 \geq P_a \times f_s$$

Confirm the selection with other parameters such as thermal power, impulse torque and any radial or axial loads acting on the male input and output shafts.

If the drive is not electric, apply the same method for the output torque required by the application rather than the nominal power.

### 4.2 Verification

#### **Gearbox input and output supports:**

these must be verified based on any radial and axial loads present. For each model, the catalog provides diagrams representing the dynamic radial loads that may be supported in accordance with the ISO 281 standard with a duration of  $L_{10}$  corresponding to  $n_x h = 100000$ . For different durations, an applicable radial load can be calculated by multiplying the values in the diagrams by the corrective factor  $k_f$ .

The radial load cannot in any case exceed the maximum value on the curve in the diagram.

Make sure that if there are axial loads, they do not exceed the maximum permitted value.

#### **Output torque:**

this must never exceed the maximum transmissible torque of the selected gearbox. Carefully check that this value is higher than the maximum torque deliverable by the motor installed, shown at the gearbox output (that is, multiplied by the actual reduction ratio and the gearbox's mechanical yield).

#### **Input speed:**

for speeds other than those shown in the table, please contact the sales office.

#### **Thermal power:**

if installed power exceeds the gearbox's thermal power, select a larger gearbox and use synthetic oil with Viton seals or use a cooling circuit.

If you use Viton seals and synthetic oil, you may consider the thermal factor equivalent to an ambient temperature lower than 20°C with respect to the actual temperature, in order to consider the fact that the gearbox can withstand overheating 20°C over the projected data.

If you use a cooling system, the power to be dissipated is

$$P_d = (P_a - P_t) \cdot (1 - \eta_m)$$

## 5.0 Order code

<b>RA</b>	<b>21</b>	<b>3</b>	<b>P</b>	<b>S</b>		<b>78.7</b>	
-----------	-----------	----------	----------	----------	--	-------------	--

**OUTPUT VERSION** G-2

**OUTPUT SHAFT** G-2

- S** = Male spline
- F** = Female spline
- C** = Cylindrical shaft
- K** = Extended cylindrical shaft
- E** = Hexagonal shaft
- Q** = Hollow female shaft
- FS** = Female spline
- FC** = Female cylindrical shaft
- U** = Female cylindrical shaft

**NUMBER OF STAGES** F-2

1 - 2 - 3 - 4 - 5 - 6

**REDUCTION RATIO** F-2

Please write the exact ratio as shown on the selection table

**GEARBOX FRAME SIZE** F-1

RE - RA	RE - RA	GB - GBA	GB - GBA
<b>110</b>	<b>1520</b>	<b>12010</b>	<b>61000</b>
<b>210</b>	<b>2000</b>	<b>16000</b>	<b>85000</b>
<b>240</b>	<b>2520</b>	<b>21000</b>	<b>110000</b>
<b>310</b>	<b>3000</b>	<b>26000</b>	<b>130000</b>
<b>510</b>	<b>3510</b>	<b>31000</b>	GB
<b>610</b>	<b>4800</b>	<b>40000</b>	<b>150000</b>
<b>810</b>	<b>6000</b>	<b>45000</b>	<b>205000</b>
<b>1020</b>	<b>8000</b>	<b>53000</b>	<b>235000</b>

**COMPOSITION** F-2

- /** = Standard
- L** = Light
- R** = Reinforced
- S** = Special

**EXECUTION** F-1

**RE - GB** = Linear      **RA - GBA** = Angular

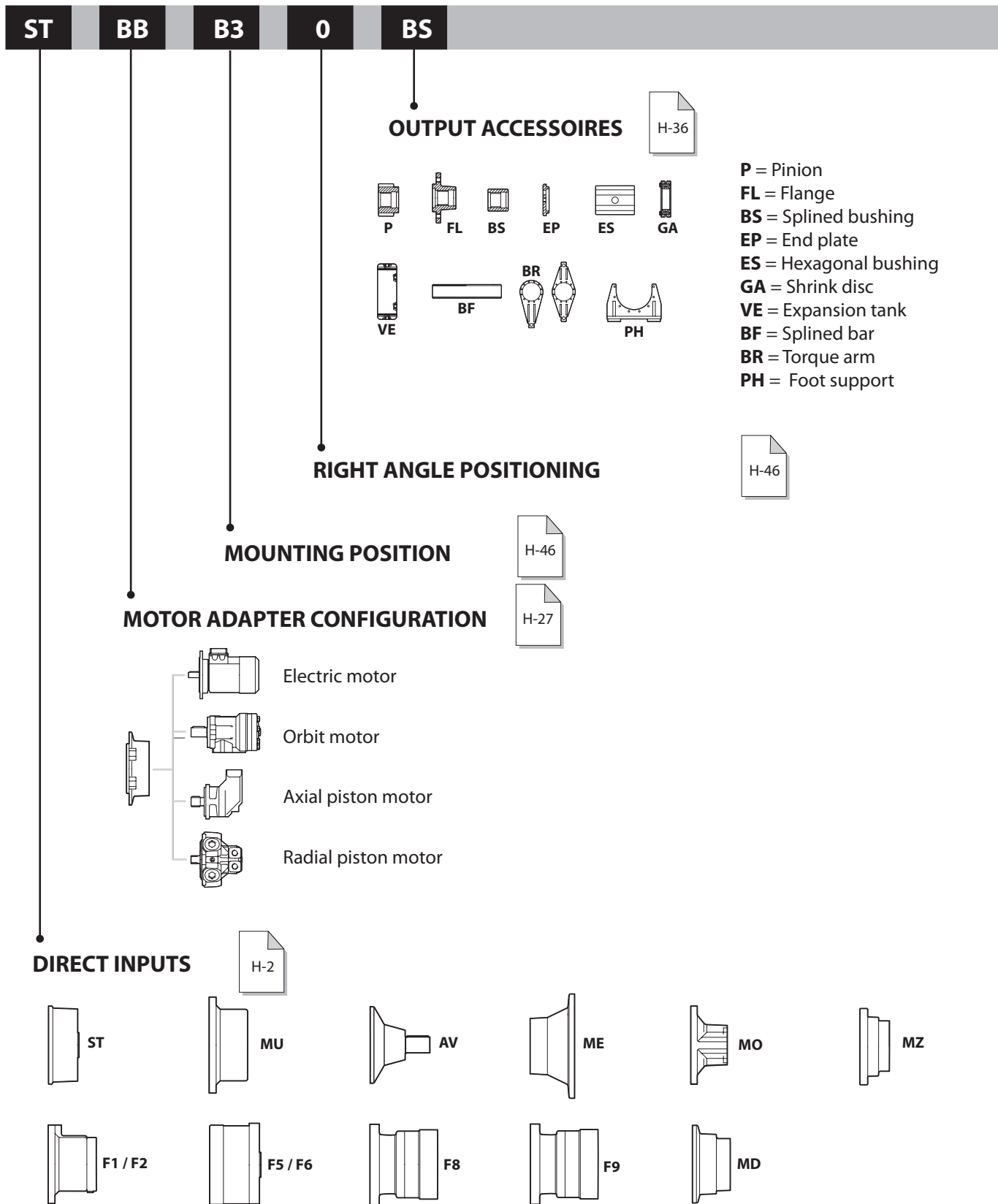

The example shows the ordering code for a right angle planetary gearbox frame 210, with 3 reduction stages a foot mounted output support and a male splined shaft, and 78.7 reduction ratio, with a "ST" input and "SAE B", 16/32 15 teeth motor adapter flange. Horizontal mounting position and standard right angle positioning, and a splined bushing output accessory.

## 6.0 Negative Hydraulic Brakes

### 6.1 1.1 Negative Hydraulic Multi disk Brakes

Dinamic Oil gearboxes may have a static negative multi disk brakes and hydraulic control.

The brakes on models **F1** through **F2** are designed for direct assembly of orbital hydraulic motors with flanging, compliant with the SAE A Standard.

The brakes on models **F5** through **F6** reach greater braking torques and have an ST universal for connection to wide range of motors available on the market.

The brakes on model **F8** reach braking torques of up to 3000 Nm and have an MU input for connection to a wide range of motors available on the market.

The brakes on model **F9** reach braking torques of up to 1500 Nm. An optional sprag clutch mechanism with a torque of up to 1200 Nm can also be mounted. They have a "SAE C" or "SAE D" input and or optional universal ST input. These can be used for connection to a wide range of motors available on the market.

The **MD** brake is assembled with a direct flange connection for MLR motors on reduction stages RE 110-240.

Braking is generated by springs which compress fixed tempered steel disks alternating with bronze disks; friction transforms this thrust into a braking torque.

The brakes open when hydraulic oil pressurizes the brake release port; the pressure acts on a piston which compresses the spring so that the disks can turn freely. These are parking brakes which act by creating static braking torque when hydraulic release pressure is zero. The action stops when hydraulic pressure reaches the minimum release value.

For the following brakes F1, F2 and standard versions of F5, F6 and F8, circa 0.1 liter of mineral oil, with an ISO VG 32 viscosity is required.

Several brake models - F5, F6, F8 and F9 - are available in special versions with a higher maximum velocity.

### 6.2 Brake Selection

The following criteria must be considered:

- Braking torques are calculated under zero release pressure; if there is counter-pressure in the hydraulic circuit the actual braking values will be reduced as follows:

Actual torque = Theoretical torque x (Opening pressure – Counter-pressure) / Pressure at the start of opening.

- Brake torque multiplied by the reduction ratio and divided by gearbox efficiency must be greater than or equal to the required output torque:

$$T_b \times i_e / \eta_m \geq T_2$$

- Except in particular cases, brake torque multiplied by the reduction ratio and divided by gearbox efficiency must not exceed the maximum gearbox torque:

$$T_b \times i_e / \eta_m \leq T_{2max}$$

## 7.0 Assembly Positions

For a complete definition of gearbox order code, it is necessary to determine the assembly position. This position defines the location of the oil filling caps, levels and drainage plugs.

See page H46 - H48.

## 8.0 Installation Instructions

The information in this chapter is indicative: it provides a partial summary of the installation and maintenance manual, which users should always refer to for more detailed information.

### 8.1 Installation

#### Gearboxes with flange and male shaft:

the coupling frame must have an unpainted, flat surface for the gearbox to rest on. The surface should be processed with machine tools and perpendicular to the axis of rotation. The table below shows the tolerance for centering on couplings. For the RE series, the centering has a tolerance of H8.

Diameter	[mm]	<b>80 - 120</b>	<b>120 - 180</b>	<b>180 - 250</b>
Tolerance	[mm]	+0.054 0	+0.063 0	+0.072 0
Diameter	[mm]	<b>250 - 315</b>	<b>315 - 400</b>	<b>400 - 500</b>
Tolerance	[mm]	+0.081 0	+0.089 0	+0.097 0

The gearboxes sized from RE1520 to RE8000 with output H have two pilot diameters. It is sufficient to use 1 pilot when the radial loads on the output shaft are not present or are less than 50% of the maximum permitted loads. For the GB line, the pilot diameter has a tolerance of F8.

Diameter	[mm]	<b>80 - 120</b>	<b>120 - 180</b>	<b>180 - 250</b>
Tolerance	[mm]	+0.186 +0.076	+0.205 +0.080	+0.226 +0.086

#### Gearboxes with a female splined shaft:

gearboxes with a female splined output shaft are not suitable for supporting radial loads on the output; it is therefore very important to carefully align the gearbox and the drive shaft. It is also necessary to check that the drive shaft does not bend while operating.

#### Gearboxes with Foot Support:

the gearbox foot support must be anchored to a flat surface and be aligned with the drive machine; it is important to align and level it very carefully. Incorrect support or alignment will affect the gearbox's lifetime.

#### Gearboxes with Pendular Assembly:

anchor the torque arm so that it is not constrained in the direction of the gearbox axis. The anchor point must have appropriate shock absorption.

The dimensional tables for each gearbox show the minimum length of the torque arm.

**Torques and corresponding axial forces exerted by large pitch screws (tab. 4)**

	Class 8.8		Class 10.9		Class 12.9	
	Torque [Nm]	Force [N]	Torque [Nm]	Force [N]	Torque [Nm]	Force [N]
<b>M10</b>	44	26000	62	37000	74.5	44000
<b>M12</b>	77	37800	108	53000	130	64000
<b>M14</b>	122	51500	172	72000	207	87000
<b>M16</b>	191	70400	269	99000	323	119000
<b>M18</b>	263	86000	370	121000	444	145000
<b>M20</b>	373	110000	525	154000	630	185000
<b>M22</b>	507	138000	714	191000	857	229000
<b>M24</b>	645	158000	908	222000	1090	267000
<b>M27</b>	944	206000	1330	289000	1590	347000
<b>M30</b>	1280	251000	1800	353000	2160	424000
<b>M33</b>	1740	311000	2460	437000	2940	525000
<b>M36</b>	2240	366000	3150	515000	3780	618000
<b>M39</b>	2900	437000	4080	615000	4890	738000
<b>M42</b>	3580	502000	5040	706000	6050	847000

## 8.2 Lubrication

### **Gearboxes are supplied without oil.**

Before use, the gearbox should be filled up to the specified level with a recommended lubricant oil. The choice and quantity of oil will be determined by the installer / user based on the type of application.

## 8.3 Paint

Gearboxes are supplied unpainted. Some parts are treated with a water-soluble base coat of red epoxy paint. The customer should paint them using a paint compatible with the base coat. Oil seals must be protected during painting

## 8.4 Assembling Flanged Motors

Assembling motors on the coupling flanges supplied by Dinamic Oil is easy, but these important recommendations should be followed:

- lubricate the coupling with a light layer of anti-seizure grease or lubricant;
- make sure the motor runs freely but snugly on the flange, anchoring the gearbox in place, without forcing the shaft or the pilot;
- tighten screws.

Refer to the installation and maintenance manual for additional information.

## 8.5 Assembling Motors with Connection Couplings

When connection couplings are used between the motor and the gearbox, ensure that the alignment is compatible with the type of coupling used. Couplings are widely used in industrial applications for a variety of functions, such as:

- limiting input torque,
- absorbing vibrations from the motor,
- compensating for small misalignments.

When using connection couplings, refer to the instruction manuals supplied by the suppliers of the component.

## 8.6 Gearbox Weight

For your information, the indicative weights of various gearboxes are provided on page H52.

## 9.0 Storage

The information in this chapter is indicative: it provides a partial summary of the installation and maintenance manual, which users should always refer to for more detailed information.

Gearboxes must not be stored outdoors or in direct contact with the ground or sun. For long-term storage they must be filled with oil, and all external parts covered with grease; coupling surfaces must be protected with rust proof agents, breather plugs replaced by closed plugs and the gearbox should be operated under no load at least once every two months (one complete turn of the output shaft is sufficient).

Refer to the installation and maintenance manual for additional information on storage.

## 10.0 Lubrication

### 10.1 Type of Lubrication

Gearboxes are lubricated in oil baths; before operating the gearbox, fill it with oil and look through the level cap to see if the oil is at the correct level; this operation requires special attention, and you must check the level again after a few minutes of operation. The oil quantities identified in the catalog are approximate and vary according to the reduction ratio and the type of gearbox input and output.

### 10.2 Selecting an Oil

You may use any mechanical transmission oil with EP additives in viscosity classes ISO VG220 to ISO VG320 under ISO 3448. In special cases, oils with different viscosities may be used; for more information on these exceptions, contact Dinamic Oil's Technical Assistance Service. Oil viscosity must be selected based on ambient temperature and the actual operating temperature of the gearbox. If the gearboxes are being operated at very high ambient temperatures, synthetic oil is recommended. Oil may suddenly overheat in gearboxes assembled vertically and continuously functioning; in these cases it is necessary to use an external expansion tank (which Dinamic Oil may supply) to allow the oil to expand through thermal dilation.

### 10.3 Changing the oil

Oil must be changed after the first 150 hours of operation, and then according to the following table, or least every 2 years.

#### Average operating duration to oil type

Operating temperature [°C]	Oil type		
	Mineraloil [h]	Syntheticoil [h]	
		Polyalfaolefins (PAO)	Polyglycols (PG)
70°	7000	15000	16000
80°	5000	10000	12000
90°	3000	7500	9000

### 10.4 Oil quantity

Information on the quantity of oil required for proper gearbox lubrication is provided on page H49.

## 10.5 Recommended lubricants

Recommended viscosity (tab. 5)

ISO VG 3448	OPERATING TEMPERATURE [C°]												
	Ambient Temperature [C°]												
	-20°	-10°	0	10°	20°	30°	40°	50°	60°	70°	80°	90°	100°
220													
320													

Recommended lubricants (tab. 6)

Lubricants for general use

Manufacturer	Mineral Oil	Synthetic Oil	
		Poly-Alpha-Olefin (PAO)	Polyglycol (PG)
AGIP	Blasia	Blasia SX	Blasia S
ARAL	Degol BG		Degol GS
BP	Energol GR-XP	Energol EPX	Energol HTX
CASTROL	Alpha SP	Alphasyn EP	Alphasyn PG
CHEVRON	Ultra Gear	Tegra Synthetic	HiPerSYN
DEA	Falcon CLP		
ELF	Reductelf SP	Elf Syntherma	Elf Syntherma
ESSO	Spartan EP	Spartan S EP	Glycolube
FINA	Giran		
IP	Mellana		Telesia Oil
KLÜBER	Kluberoil GEM 1	Klubersynt EG4	Klubersynt GH6
MOBIL	Mobilgear XMP	Mobilgear SHC	Glygoile
OPTIMOL	Ultra		
Q8	Goya	El Greco	El Greco
SHELL	Omala S2 G	Omala S4 GX	Omala S4 WE
TOTAL	Carter EP	Carter SH	Carter SY

Lubricants for food use

Manufacturer	Gear Oils
AGIP	Rocol Foodlube Hi-Torque
ESSO	Gear Oil FM
KLÜBER	Kluberoil 4 UH1 N
MOBIL	DTE FM
SHELL	Cassida Fluid GL

## 10.6 Temperature

The recommended ambient temperature for use of standard gearboxes is from -15°C to +40°C.

## 11.0 Independent Cooling Units

When transmitted power exceeds the thermal power that may be dissipated by the reducer, it is necessary to use a cooling unit to dispose of excessive thermal power.

Dinamic Oil offers a series of independent oil/water and oil/air cooling units which can dissipate up to 50 kW. For greater power levels, contact our technical office.

### 11.1 Independent oil/water cooling units, standard and customized composition.

Standard series URO/W cooling units are composed of:

- A water/oil heat exchanger.
- A motor-driven pump (motor/pump connection with joint and support; pump with viton seals) composed of a 4 pole B5 motor, standard three-phase 230/400V 50Hz power supply and gear pump.
- 0-16 bar manometer assembled between pump and heat exchanger.
- Analogue 0-120 °C thermometer mounted at the exchanger exit.
- Filter for installation on the tank delivery for cleaning the oil released (recommended option).

Units in customized installations may be equipped with the following options:

- Minimum pressure switch with exchange contacts, for assembly between the pump and the heat exchanger. (In this case the hydraulic system is already prepared).
- Electric flow switch for total control of oil flow. .

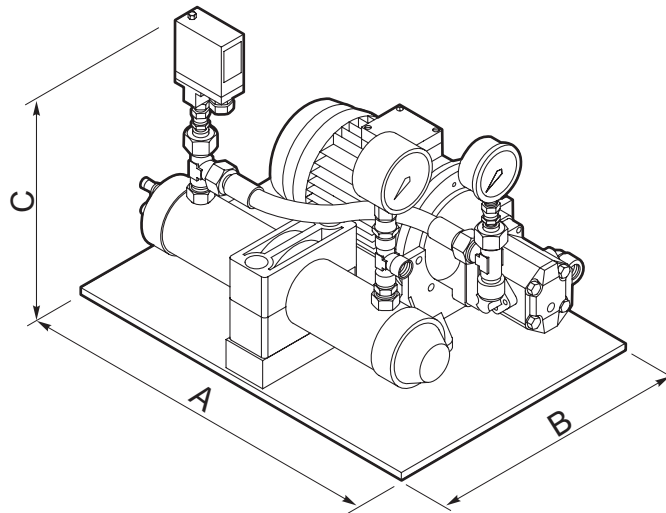

Unit	Capacity [kW]*	Motor-driven oil pump		Water quantity [l/min]*	A	B	C
		[kW]	[l/min]				
URO/W 4	4	0.37	16	8	500	350	400
URO/W 6	6	0.37	16	10	500	350	400
URO/W 9	9	0.55	16	16	500	350	400
URO/W 13	13	1.1	30	25	500	350	400
URO/W 21	21	1.5	30	40	500	400	450
URO/W 31	31	2.2	56	50	720	510	520
URO/W 50	50	3.0	80	80	730	520	520

\* The values appearing in the table are for a water temperature of 20° C..

## 11.2 Independent oil/air cooling units, standard and customized composition

Standard series URO/A cooling units are composed of:

- An air/oil heat exchanger complete with a fan and an adjustable 0-90 ° C thermostat, already wired.
- A motor-driven pump (motor/pump connection with joint and support; pump with viton seals) composed of a 4 pole B3/ B5 motor, standard 230/400V - 50Hz power supply and screw pump.
- 0-16 bar manometer assembled between pump and heat exchanger.
- Analogue 0-120 ° C thermometer mounted at the exchanger exit.
- Filter for installation on the tank delivery for cleaning the oil released (recommended option).

Units in customized installations may be equipped with the following options:

- Minimum pressure switch with exchange contacts, for assembly between the pump and the heat exchanger. (In this case the hydraulic system is already prepared).
- Electric flow switch for total control of oil flow.
- Filter for installation on the tank delivery for cleaning the oil released (recommended option).

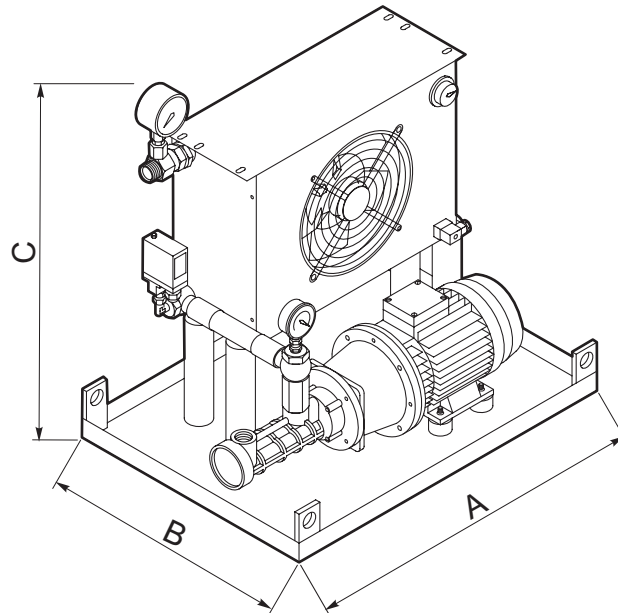

Unit	Capacity [kW]*	Motor-driven oil pump		Motor-driven fan		A	B	C
		[kW]	[l/min]	[kW]	[m <sup>3</sup> /h]			
URO/A 5	5	1.5	30	0.12	900	660	430	700
URO/A 7	7	1.5	30	0.12	1300	710	510	700
URO/A 10	10	1.5	30	0.18	2750	710	510	830
URO/A 13	13	1.5	30	0.23	2750	710	510	830
URO/A 16	16	2.2	56	0.23	3500	710	510	1010
URO/A 21	21	2.2	56	0.56	6300	800	500	1200
URO/A 26	26	3	56	0.56	7450	800	500	1265
URO/A 30	30	3	80	0.56	7450	800	500	1265
URO/A 40	40	2.2	56	0.9	9500	1010	600	1350
URO/A 46	46	3	80	0.9	9500	1010	600	1350

\* The values appearing in the table are for a air temperature of 20° C.

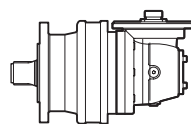
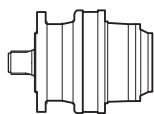

RE	ie	RA	ie	T <sub>2max</sub> [Nm]	
<b>110</b>	3.48 - 2153.35	<b>110</b>	11.14 - 1194.39	<b>1780</b>	<b>F-2</b>
<b>210</b>	3.48 - 2153.35	<b>210</b>	11.14 - 1194.39	<b>3600</b>	<b>F-4</b>
<b>240</b>	3.82 - 1658.88	<b>240</b>	12.22 - 900.53	<b>4000</b>	<b>F-6</b>
<b>310</b>	3.60 - 1990.66	<b>310</b>	10.03 - 1244.16	<b>5630</b>	<b>F-8</b>
<b>510</b>	3.60 - 1990.66	<b>510</b>	10.03 - 1244.16	<b>11600</b>	<b>F-10</b>
<b>610</b>	4.00 - 1416.08	<b>610</b>	11.14 - 629.37	<b>14900</b>	<b>F-12</b>
<b>810</b>	3.56 - 2264.19	<b>810</b>	10.41 - 1184.91	<b>18600</b>	<b>F-14</b>
<b>1020</b>	3.56 - 2264.19	<b>1020</b>	10.41 - 1184.91	<b>27200</b>	<b>F-16</b>
<b>1520</b>	4.09 - 2041.20	<b>1520</b>	12.56 - 1076.68	<b>39000</b>	<b>F-18</b>
<b>2000</b>	3.83 - 1451.52	<b>2000</b>	11.77 - 907.20	<b>44100</b>	<b>F-20</b>
<b>2520</b>	4.00 - 1925.49	<b>2520</b>	12.29 - 1091.91	<b>50100</b>	<b>F-22</b>
<b>3000</b>	4.00 - 1742.52	<b>3000</b>	12.29 - 968.07	<b>78800</b>	<b>F-24</b>
<b>3510</b>	3.84 - 2392.62	<b>3510</b>	12.48 - 1118.57	<b>96500</b>	<b>F-26</b>
<b>4800</b>	3.84 - 1741.68	<b>4800</b>	12.48 - 967.60	<b>111000</b>	<b>F-28</b>
<b>6000</b>	4.14 - 1435.91	<b>6000</b>	13.46 - 1009.38	<b>135000</b>	<b>F-30</b>
<b>8000</b>	4.00 - 3164.84	<b>8000</b>	13.00 - 800.00	<b>198000</b>	<b>F-32</b>

GB	ie	GBA	ie	T <sub>2max</sub> [Nm]	
<b>12010</b>	4.09 - 3544.35	<b>12010</b>	48.55 - 3161.48	<b>281000</b>	<b>F-34</b>
<b>16000</b>	3.83 - 3172.87	<b>16000</b>	47.84 - 3544.35	<b>357000</b>	<b>F-36</b>
<b>21000</b>	3.68 - 3129.84	<b>21000</b>	49.55 - 3065.78	<b>406000</b>	<b>F-38</b>
<b>26000</b>	3.68 - 3532.80	<b>26000</b>	55.81 - 2527.69	<b>540000</b>	<b>F-40</b>
<b>31000</b>	3.43 - 3559.02	<b>31000</b>	172.32 - 5011.04	<b>650000</b>	<b>F-42</b>
<b>40000</b>	3.43 - 3559.02	<b>40000</b>	172.32 - 5011.04	<b>650000</b>	<b>F-44</b>
<b>45000</b>	3.83 - 3554.59	<b>45000</b>	210.50 - 2211.75	<b>650000</b>	<b>F-46</b>
<b>53000</b>	3.84 - 3103.82	<b>53000</b>	248.00 - 4278.67	<b>1191000</b>	<b>F-48</b>
<b>61000</b>	3.84 - 2943.14	<b>61000</b>	190.27 - 11772.58	<b>1131000</b>	<b>F-50</b>
<b>85000</b>	3.84 - 2448.10	<b>85000</b>	214.32 - 11429.12	<b>1131000</b>	<b>F-52</b>
<b>110000</b>	4.32 - 3553.28	<b>110000</b>	744.42 - 21647.68	<b>2250000</b>	<b>F-54</b>
<b>130000</b>	4.32 - 2350.11	<b>130000</b>	909.34 - 10967.19	<b>2720000</b>	<b>F-56</b>
<b>150000</b>	4.07 - 2344.94			<b>2720000</b>	<b>F-58</b>
<b>205000</b>	4.14 - 3259.83			<b>3620000</b>	<b>F-59</b>
<b>235000</b>	4.14 - 2902.95			<b>3620000</b>	<b>F-60</b>

**Carichi radiali e assiali**  
**Radial and Axial loads**

**F-61**



	ie	n <sub>1</sub> = 750 RPM			n <sub>1</sub> = 900 RPM			n <sub>1</sub> = 1450 RPM			n <sub>1</sub> = 2900 RPM			T <sub>2max</sub> [Nm]	P <sub>t</sub> [kW]
		n <sub>2</sub> [RPM]	P <sub>1</sub> [kW]	T <sub>2</sub> [Nm]	n <sub>2</sub> [RPM]	P <sub>1</sub> [kW]	T <sub>2</sub> [Nm]	n <sub>2</sub> [RPM]	P <sub>1</sub> [kW]	T <sub>2</sub> [Nm]	n <sub>2</sub> [RPM]	P <sub>1</sub> [kW]	T <sub>2</sub> [Nm]		
RE 111	3.48	216	14.7	630	259	16.8	610	417	23.5	530	833	38.2	430	1730	11 (N) 13 (T) 8 (F) 21 (P)
	4.26	176	12.2	650	211	14.4	640	340	20.1	550	680	32.7	450	1780	
	5.77	130	6.7	480	156	7.9	470	251	12.4	460	503	23.9	440	1320	
	7.20	104	3.8	340	125	4.6	340	201	7.1	330	403	13.7	320	950	
RE 112	12.11	62	4.6	680	74	5.5	670	120	8.6	660	239	16.4	620	1730	7 (N) 8 (T) 5 (F) 13 (P)
	14.84	51	3.8	690	61	4.6	680	98	7.1	660	195	13.7	640	1730	
	18.17	41.3	3.2	700	49.5	3.8	700	80	6.0	680	160	11.4	650	1780	
	20.08	37.4	2.9	700	44.8	3.4	690	72	5.4	670	144	10.3	650	1730	
	24.60	30.5	2.4	720	36.6	2.9	710	59	4.5	690	118	8.6	660	1780	
	30.69	24.4	2.0	720	29.3	2.3	720	47.2	3.6	700	94	7.0	670	1780	
	33.28	22.5	1.3	530	27.0	1.6	520	43.6	2.4	510	87	4.7	490	1320	
	41.54	18.1	1.1	530	21.7	1.3	530	34.9	2.0	510	70	3.8	490	1320	
51.84	14.5	0.61	380	17.4	0.73	380	28.0	1.1	370	56	2.2	350	950		
RE 113	51.63	14.5	1.2	750	17.4	1.5	740	28.1	2.3	720	56	4.4	690	1730	5 (N) 6 (T) 4 (F) 10 (P)
	63.25	11.9	1.0	760	14.2	1.2	750	22.9	1.9	730	45.9	3.6	700	1780	
	69.87	10.7	0.92	750	12.9	1.1	740	20.8	1.7	720	41.5	3.3	700	1730	
	77.48	9.7	0.84	760	11.6	0.99	760	18.7	1.6	740	37.4	3.0	710	1780	
	85.59	8.8	0.76	770	10.5	0.90	760	16.9	1.4	740	33.9	2.7	710	1780	
	104.85	7.2	0.64	790	8.6	0.75	770	13.8	1.2	750	27.7	2.2	720	1780	
	106.82	7.0	0.63	790	8.4	0.73	770	13.6	1.1	750	27.1	2.2	720	1780	
	130.86	5.7	0.53	820	6.9	0.62	800	11.1	0.95	760	22.2	1.8	730	1780	
	141.90	5.3	0.49	830	6.3	0.58	810	10.2	0.88	760	20.4	1.7	730	1780	
	144.55	5.2	0.49	840	6.2	0.58	820	10.0	0.86	760	20.1	1.6	730	1730	
	177.09	4.2	0.41	860	5.1	0.48	830	8.2	0.72	770	16.4	1.4	740	1780	
	180.40	4.2	0.41	870	5.0	0.48	850	8.0	0.72	790	16.1	1.3	730	1730	
	221.00	3.4	0.34	880	4.1	0.40	860	6.6	0.59	800	13.1	1.1	750	1780	
	239.64	3.1	0.22	630	3.8	0.26	610	6.1	0.39	570	12.1	0.75	550	1320	
299.08	2.5	0.18	650	3.0	0.21	630	4.8	0.32	590	9.7	0.61	550	1320		
RE 114	220.10	3.4	0.35	880	4.1	0.41	860	6.6	0.61	800	13.2	1.1	750	1780	4 (N) 5 (T) 4 (F) 8 (P)
	243.14	3.1	0.33	910	3.7	0.38	890	6.0	0.57	830	11.9	1.0	750	1730	
	269.63	2.8	0.29	910	3.3	0.34	890	5.4	0.51	830	10.8	0.95	760	1780	
	303.44	2.5	0.27	940	3.0	0.32	920	4.8	0.47	850	9.6	0.85	770	1730	
	364.89	2.1	0.23	950	2.5	0.27	930	4.0	0.40	860	7.9	0.72	780	1780	
	403.08	1.9	0.21	980	2.2	0.25	960	3.6	0.37	890	7.2	0.67	800	1730	
	447.00	1.7	0.19	980	2.0	0.22	960	3.2	0.33	890	6.5	0.60	800	1780	
	493.79	1.5	0.18	1000	1.8	0.21	970	2.9	0.31	900	5.9	0.55	810	1780	
	557.86	1.3	0.16	1020	1.6	0.19	990	2.6	0.28	920	5.2	0.50	830	1780	
	627.80	1.2	0.15	1050	1.4	0.17	1020	2.3	0.25	950	4.6	0.46	860	1730	
	818.63	0.92	0.11	1080	1.1	0.13	1050	1.8	0.20	980	3.5	0.36	880	1780	
	942.17	0.80	0.10	1100	0.96	0.12	1070	1.5	0.18	1000	3.1	0.32	900	1780	
	1021.64	0.73	0.09	1120	0.88	0.11	1090	1.4	0.17	1010	2.8	0.30	910	1780	
	1275.01	0.59	0.08	1150	0.71	0.09	1120	1.1	0.14	1040	2.3	0.25	940	1780	
	1591.22	0.47	0.07	1190	0.57	0.08	1160	0.91	0.11	1080	1.8	0.21	970	1780	
	1725.44	0.43	0.04	840	0.52	0.05	820	0.84	0.07	760	1.7	0.13	690	1320	
	2153.35	0.35	0.04	870	0.42	0.04	850	0.67	0.06	790	1.3	0.11	710	1320	

	ie	n <sub>1</sub> = 750 RPM			n <sub>1</sub> = 900 RPM			n <sub>1</sub> = 1450 RPM			n <sub>1</sub> = 2900 RPM			T <sub>2max</sub> [Nm]	P <sub>t</sub> [kW]
		n <sub>2</sub> [RPM]	P <sub>1</sub> [kW]	T <sub>2</sub> [Nm]	n <sub>2</sub> [RPM]	P <sub>1</sub> [kW]	T <sub>2</sub> [Nm]	n <sub>2</sub> [RPM]	P <sub>1</sub> [kW]	T <sub>2</sub> [Nm]	n <sub>2</sub> [RPM]	P <sub>1</sub> [kW]	T <sub>2</sub> [Nm]		
RA 112	11.14	67.3	5.1	680	81	6.1	670	130	9.5	650	260	16.4	560	1730	5 (N) 5 (T) 4 (F) 9 (P)
	13.64	55.0	4.3	690	66	5.1	680	106	7.9	670	213	15.1	630	1780	
	18.46	40.6	2.3	510	48.8	2.8	500	79	4.3	490	157	8.3	470	1320	
	23.04	32.6	1.3	370	39.1	1.6	360	63	2.5	350	126	4.8	340	950	
RA 113	38.75	19.4	1.6	730	23.2	1.9	720	37.4	3.0	700	75	5.8	670	1730	4 (N) 5 (T) 3 (F) 8 (P)
	47.47	15.8	1.3	740	19.0	1.6	740	30.5	2.5	720	61	4.8	690	1780	
	58.16	12.9	1.1	750	15.5	1.3	740	24.9	2.1	720	49.9	4.0	700	1780	
	64.25	11.7	1.0	750	14.0	1.2	740	22.6	1.9	720	45.1	3.6	690	1730	
	78.70	9.5	0.84	770	11.4	0.99	760	18.4	1.6	740	36.8	3.0	710	1780	
	98.22	7.6	0.69	780	9.2	0.81	770	14.8	1.3	750	29.5	2.4	720	1780	
	106.51	7.0	0.46	560	8.5	0.54	560	13.6	0.85	540	27.2	1.6	520	1320	
	132.92	5.6	0.37	570	6.8	0.44	570	10.9	0.69	550	21.8	1.3	530	1320	
	165.89	4.5	0.21	410	5.4	0.25	410	8.7	0.40	390	17.5	0.76	380	950	
RA 114	134.86	5.6	0.55	830	6.7	0.64	810	10.8	0.95	750	21.5	1.8	720	1730	4 (N) 4 (T) 3 (F) 8 (P)
	165.21	4.5	0.45	850	5.4	0.53	820	8.8	0.79	770	17.6	1.5	740	1780	
	202.39	3.7	0.38	870	4.4	0.44	850	7.2	0.67	790	14.3	1.3	750	1780	
	223.58	3.4	0.36	900	4.0	0.41	880	6.5	0.62	810	13.0	1.1	740	1730	
	247.94	3.0	0.32	900	3.6	0.37	880	5.8	0.56	810	11.7	1.0	760	1780	
	273.89	2.7	0.29	910	3.3	0.34	890	5.3	0.52	830	10.6	0.95	760	1780	
	335.53	2.2	0.25	940	2.7	0.29	920	4.3	0.43	850	8.6	0.78	770	1780	
	341.82	2.2	0.24	950	2.6	0.28	920	4.2	0.43	860	8.5	0.77	770	1780	
	418.74	1.8	0.21	970	2.1	0.24	950	3.5	0.36	880	6.9	0.65	790	1780	
	454.06	1.7	0.19	990	2.0	0.22	960	3.2	0.34	890	6.4	0.60	800	1780	
	566.67	1.3	0.16	1020	1.6	0.19	990	2.6	0.28	920	5.1	0.50	830	1780	
	614.47	1.2	0.10	720	1.5	0.12	700	2.4	0.18	650	4.7	0.33	590	1320	
	707.21	1.1	0.13	1060	1.3	0.15	1030	2.1	0.23	960	4.1	0.41	860	1780	
	766.86	0.98	0.09	750	1.2	0.10	730	1.9	0.15	680	3.8	0.27	610	1320	
	957.05	0.78	0.07	770	0.94	0.08	750	1.5	0.12	700	3.0	0.22	630	1320	
	1194.39	0.63	0.04	550	0.75	0.05	540	1.2	0.07	500	2.4	0.13	450	950	

# RE 210



	ie	n <sub>1</sub> = 750 RPM			n <sub>1</sub> = 900 RPM			n <sub>1</sub> = 1450 RPM			n <sub>1</sub> = 2900 RPM			T <sub>2max</sub> [Nm]	P <sub>t</sub> [kW]
		n <sub>2</sub> [RPM]	P <sub>1</sub> [kW]	T <sub>2</sub> [Nm]	n <sub>2</sub> [RPM]	P <sub>1</sub> [kW]	T <sub>2</sub> [Nm]	n <sub>2</sub> [RPM]	P <sub>1</sub> [kW]	T <sub>2</sub> [Nm]	n <sub>2</sub> [RPM]	P <sub>1</sub> [kW]	T <sub>2</sub> [Nm]		
RE 211	3.48	216	26.5	1140	259	30.1	1080	417	42.0	940	833	68	760	2420	11 (N) 13 (T) 9 (F) 22 (P)
	4.26	176	22.7	1200	211	25.7	1140	340	36.0	980	680	58	800	3550	
	5.77	130	13.4	960	156	16.0	950	251	25.0	930	503	45.8	850	2650	
	7.20	104	7.8	690	125	9.2	690	201	14.4	670	403	27.8	640	1920	
RE 212	12.11	62	9.7	1410	74	11.5	1400	120	18.0	1360	239	29.3	1110	2420	7 (N) 8 (T) 5 (F) 13 (P)
	14.84	51	7.7	1390	61	9.2	1380	98	14.4	1340	195	25.0	1160	3550	
	18.17	41.3	6.4	1410	49.5	7.6	1390	80	11.9	1360	160	21.7	1240	3550	
	20.08	37.4	6.0	1460	44.8	7.1	1440	72	11.2	1400	144	20.5	1290	2420	
	24.60	30.5	4.8	1430	36.6	5.7	1420	59	9.0	1380	118	17.2	1330	3550	
	30.69	24.4	3.9	1450	29.3	4.6	1430	47.2	7.3	1400	94	14.0	1340	3550	
	33.28	22.5	2.6	1060	27.0	3.1	1050	43.6	4.9	1030	87	9.5	990	2650	
	41.54	18.1	2.1	1080	21.7	2.5	1070	34.9	4.0	1040	70	7.7	1000	2650	
51.84	14.5	1.2	780	17.4	1.5	770	28.0	2.3	750	56	4.4	720	1920		
RE 213	51.63	14.5	2.5	1490	17.4	2.9	1480	28.1	4.6	1440	56	8.8	1380	3550	5 (N) 6 (T) 4 (F) 10 (P)
	63.25	11.9	2.0	1510	14.2	2.4	1500	22.9	3.8	1460	45.9	7.2	1400	3550	
	69.87	10.7	1.9	1570	12.9	2.3	1550	20.8	3.5	1510	41.5	6.8	1450	2420	
	77.48	9.7	1.7	1530	11.6	2.0	1510	18.7	3.1	1470	37.4	6.0	1420	3550	
	85.59	8.8	1.5	1540	10.5	1.8	1520	16.9	2.8	1480	33.9	5.4	1420	3550	
	104.85	7.2	1.3	1580	8.6	1.5	1540	13.8	2.3	1500	27.7	4.5	1440	3550	
	106.82	7.0	1.3	1590	8.4	1.5	1540	13.6	2.3	1500	27.1	4.4	1440	3550	
	130.86	5.7	1.1	1630	6.9	1.2	1590	11.1	1.9	1520	22.2	3.7	1460	3550	
	141.90	5.3	1.0	1660	6.3	1.2	1610	10.2	1.8	1520	20.4	3.4	1460	3550	
	144.55	5.2	1.0	1750	6.2	1.2	1700	10.0	1.8	1590	20.1	3.4	1510	2420	
	177.09	4.2	0.82	1710	5.1	1.0	1660	8.2	1.4	1550	16.4	2.7	1480	3550	
	180.40	4.2	0.63	1330	5.0	0.74	1320	8.0	1.2	1290	16.1	2.2	1240	3290	
	221.00	3.4	0.63	1630	4.1	0.74	1620	6.6	1.2	1570	13.1	2.2	1500	3550	
239.64	3.1	0.45	1260	3.8	0.52	1230	6.1	0.78	1150	12.1	1.5	1100	2650		
299.08	2.5	0.37	1310	3.0	0.43	1270	4.8	0.65	1180	9.7	1.2	1120	2650		
RE 214	220.10	3.4	0.70	1770	4.1	0.82	1720	6.6	1.22	1600	13.2	2.3	1500	3550	5 (N) 5 (T) 4 (F) 8 (P)
	243.14	3.1	0.68	1900	3.7	0.79	1840	6.0	1.19	1720	11.9	2.1	1550	2420	
	269.63	2.8	0.59	1820	3.3	0.69	1770	5.4	1.03	1650	10.8	1.9	1520	3550	
	303.44	2.5	0.56	1960	3.0	0.66	1910	4.8	0.98	1770	9.6	1.8	1600	2420	
	364.89	2.1	0.45	1910	2.5	0.53	1860	4.0	0.80	1730	7.9	1.4	1560	3550	
	403.08	1.9	0.43	1970	2.2	0.50	1950	3.6	0.77	1850	7.2	1.4	1670	2420	
	447.00	1.7	0.38	1970	2.0	0.45	1920	3.2	0.67	1780	6.5	1.2	1600	3550	
	493.79	1.5	0.35	2000	1.8	0.41	1940	2.9	0.62	1810	5.9	1.1	1630	3550	
	557.86	1.3	0.32	2040	1.6	0.37	1980	2.6	0.55	1840	5.2	1.0	1660	3550	
	627.80	1.2	0.30	2190	1.4	0.35	2130	2.3	0.53	1980	4.6	0.95	1780	2420	
	818.63	0.92	0.23	2160	1.1	0.27	2100	1.8	0.40	1950	3.5	0.72	1760	3550	
	942.17	0.80	0.20	2200	0.96	0.24	2140	1.5	0.36	1990	3.1	0.64	1800	3550	
	1021.64	0.73	0.19	2230	0.88	0.22	2170	1.4	0.33	2020	2.8	0.60	1820	3550	
	1275.01	0.59	0.16	2310	0.71	0.18	2240	1.1	0.28	2090	2.3	0.50	1880	3550	
	1591.22	0.47	0.11	1970	0.57	0.13	1920	0.91	0.19	1790	1.8	0.36	1690	3550	
	1725.44	0.43	0.09	1700	0.52	0.10	1660	0.84	0.15	1540	1.7	0.27	1390	2650	
2153.35	0.35	0.07	1760	0.42	0.08	1710	0.67	0.12	1590	1.3	0.22	1440	2650		

	ie	n <sub>1</sub> = 750 RPM			n <sub>1</sub> = 900 RPM			n <sub>1</sub> = 1450 RPM			n <sub>1</sub> = 2900 RPM			T <sub>2max</sub> [Nm]	P <sub>t</sub> [kW]
		n <sub>2</sub> [RPM]	P <sub>1</sub> [kW]	T <sub>2</sub> [Nm]	n <sub>2</sub> [RPM]	P <sub>1</sub> [kW]	T <sub>2</sub> [Nm]	n <sub>2</sub> [RPM]	P <sub>1</sub> [kW]	T <sub>2</sub> [Nm]	n <sub>2</sub> [RPM]	P <sub>1</sub> [kW]	T <sub>2</sub> [Nm]		
RA 212	11.14	67	7.1	940	81	8.4	930	130	12.4	850	260	20.2	690	2410	5 (N) 6 (T) 4 (F) 9 (P)
	13.64	55	7.1	1150	66	8.4	1140	106	12.4	1050	213	20.2	850	2950	
	18.46	40.6	4.7	1030	48.8	5.6	1020	79	8.7	990	157	16.7	950	2650	
	23.04	32.6	2.7	740	39.1	3.2	730	63	5.0	710	126	9.7	690	1920	
RA 213	38.75	19.4	3.4	1510	23.2	4.0	1500	37.4	6.3	1460	75	12.0	1400	2420	4 (N) 5 (T) 4 (F) 8 (P)
	47.47	15.8	2.8	1530	19.0	3.2	1470	30.5	5.0	1430	61	9.6	1380	3550	
	58.16	12.9	2.2	1500	15.5	2.6	1490	24.9	4.1	1450	49.9	8.0	1390	3550	
	64.25	11.7	2.1	1560	14.0	2.5	1540	22.6	3.9	1500	45.1	7.5	1440	2420	
	78.70	9.5	1.7	1530	11.4	2.0	1510	18.4	3.1	1470	36.8	6.0	1420	3550	
	98.22	7.6	1.4	1560	9.2	1.6	1530	14.8	2.5	1490	29.5	4.9	1430	3550	
	106.51	7.0	0.92	1140	8.5	1.1	1130	13.6	1.7	1100	27.2	3.3	1050	2650	
	132.92	5.6	0.75	1160	6.8	0.89	1140	10.9	1.4	1110	21.8	2.7	1070	2650	
	165.89	4.5	0.43	830	5.4	0.51	820	8.7	0.80	800	17.5	1.5	770	1920	
RA 214	134.86	5.6	1.1	1730	6.7	1.3	1690	10.8	2.0	1570	21.5	3.8	1500	2420	4 (N) 4 (T) 3 (F) 8 (P)
	165.21	4.5	0.90	1690	5.4	1.1	1650	8.8	1.6	1540	17.6	3.1	1480	3550	
	202.39	3.7	0.76	1750	4.4	0.89	1700	7.2	1.3	1580	14.3	2.5	1490	3550	
	223.58	3.4	0.74	1870	4.0	0.86	1820	6.5	1.3	1690	13.0	2.4	1550	2420	
	247.94	3.0	0.64	1800	3.6	0.75	1750	5.8	1.1	1630	11.7	2.1	1510	3550	
	273.89	2.7	0.59	1830	3.3	0.69	1780	5.3	1.0	1650	10.6	1.9	1520	3550	
	335.53	2.2	0.50	1890	2.7	0.58	1830	4.3	0.87	1710	8.6	1.6	1540	3550	
	341.82	2.2	0.49	1890	2.6	0.57	1840	4.2	0.85	1710	8.5	1.5	1540	3550	
	418.74	1.8	0.41	1950	2.1	0.48	1900	3.5	0.72	1760	6.9	1.3	1590	3550	
	454.06	1.7	0.38	1970	2.0	0.45	1920	3.2	0.67	1790	6.4	1.2	1610	3550	
	566.67	1.3	0.32	2040	1.6	0.37	1990	2.6	0.56	1850	5.1	1.0	1660	3550	
	614.47	1.2	0.21	1460	1.5	0.24	1420	2.4	0.37	1320	4.7	0.66	1190	2650	
	707.21	1.1	0.22	1750	1.3	0.26	1730	2.1	0.41	1680	4.1	0.78	1620	3550	
	766.86	1.0	0.17	1510	1.2	0.20	1470	1.9	0.30	1360	3.8	0.55	1230	2650	
	957.05	0.78	0.14	1560	0.94	0.17	1520	1.5	0.25	1410	3.0	0.45	1270	2650	
	1194.39	0.63	0.08	1120	0.75	0.10	1090	1.2	0.14	1010	2.4	0.26	910	1920	

	ie	n <sub>1</sub> = 750 RPM			n <sub>1</sub> = 900 RPM			n <sub>1</sub> = 1450 RPM			n <sub>1</sub> = 2900 RPM			T <sub>2max</sub> [Nm]	P <sub>t</sub> [kW]
		n <sub>2</sub> [RPM]	P <sub>1</sub> [kW]	T <sub>2</sub> [Nm]	n <sub>2</sub> [RPM]	P <sub>1</sub> [kW]	T <sub>2</sub> [Nm]	n <sub>2</sub> [RPM]	P <sub>1</sub> [kW]	T <sub>2</sub> [Nm]	n <sub>2</sub> [RPM]	P <sub>1</sub> [kW]	T <sub>2</sub> [Nm]		
<b>RE 241</b>	<b>3.82</b>	196	<b>32.8</b>	1550	236	<b>37.2</b>	1470	380	<b>51.98</b>	1270	760	<b>84</b>	1040	4010	13 (T) 9 (F)
	<b>4.44</b>	169	<b>29.0</b>	1600	203	<b>32.9</b>	1520	326	<b>46.01</b>	1310	653	<b>75</b>	1070	4010	
	<b>5.43</b>	138	<b>19.7</b>	1330	166	<b>23.4</b>	1310	267	<b>36.67</b>	1280	534	<b>64</b>	1110	3710	
<b>RE 242</b>	<b>13.29</b>	56	<b>12.5</b>	2000	68	<b>14.8</b>	1980	109	<b>22.27</b>	1850	218	<b>36.2</b>	1500	4010	8 (T) 5 (F)
	<b>15.47</b>	48.5	<b>9.4</b>	1760	58	<b>11.2</b>	1740	94	<b>17.48</b>	1690	188	<b>32.0</b>	1550	4010	
	<b>16.28</b>	46.1	<b>10.3</b>	2030	55	<b>12.2</b>	2010	89	<b>19.15</b>	1950	178	<b>31.4</b>	1600	4010	
	<b>18.95</b>	39.6	<b>7.8</b>	1780	47.5	<b>9.2</b>	1760	77	<b>14.44</b>	1710	153	<b>27.8</b>	1650	4010	
	<b>22.03</b>	34.0	<b>6.8</b>	1820	40.9	<b>8.1</b>	1800	66	<b>12.73</b>	1760	132	<b>24.5</b>	1690	4010	
	<b>25.64</b>	29.3	<b>5.8</b>	1810	35.1	<b>6.9</b>	1790	57	<b>10.85</b>	1740	113	<b>20.9</b>	1670	4010	
	<b>27.49</b>	27.3	<b>3.9</b>	1310	32.7	<b>4.7</b>	1290	53	<b>7.32</b>	1260	105	<b>14.1</b>	1210	3610	
	<b>31.32</b>	23.9	<b>3.9</b>	1470	28.7	<b>4.6</b>	1450	46.3	<b>7.20</b>	1410	93	<b>13.9</b>	1360	3710	
	<b>39.09</b>	19.2	<b>3.1</b>	1490	23.0	<b>3.7</b>	1470	37.1	<b>5.85</b>	1430	74	<b>11.2</b>	1380	3710	
<b>RE 243</b>	<b>46.24</b>	16.2	<b>3.9</b>	2150	19.5	<b>4.7</b>	2130	31.4	<b>7.34</b>	2070	63	<b>14.1</b>	1990	4010	6 (T) 4 (F)
	<b>53.82</b>	13.9	<b>3.0</b>	1890	16.7	<b>3.5</b>	1870	26.9	<b>5.53</b>	1820	54	<b>10.6</b>	1750	4010	
	<b>56.65</b>	13.2	<b>3.3</b>	2180	15.9	<b>3.9</b>	2150	25.6	<b>6.06</b>	2100	51	<b>11.7</b>	2010	4010	
	<b>65.94</b>	11.4	<b>2.5</b>	1910	13.6	<b>2.9</b>	1890	22.0	<b>4.57</b>	1840	44.0	<b>8.8</b>	1770	4010	
	<b>69.39</b>	10.8	<b>2.7</b>	2200	13.0	<b>3.2</b>	2180	20.9	<b>5.01</b>	2120	41.8	<b>9.6</b>	2040	4010	
	<b>76.66</b>	9.8	<b>2.4</b>	2210	11.7	<b>2.9</b>	2190	18.9	<b>4.56</b>	2130	37.8	<b>8.8</b>	2050	4010	
	<b>93.91</b>	8.0	<b>2.0</b>	2240	9.6	<b>2.4</b>	2220	15.4	<b>3.76</b>	2160	30.9	<b>7.2</b>	2070	4010	
	<b>95.67</b>	7.8	<b>2.0</b>	2240	9.4	<b>2.4</b>	2220	15.2	<b>3.70</b>	2160	30.3	<b>7.1</b>	2080	4010	
	<b>111.36</b>	6.7	<b>1.5</b>	1970	8.1	<b>1.8</b>	1950	13.0	<b>2.79</b>	1900	26.0	<b>5.4</b>	1820	4010	
	<b>117.20</b>	6.4	<b>1.7</b>	2300	7.7	<b>1.9</b>	2250	12.4	<b>3.05</b>	2180	24.7	<b>5.9</b>	2100	4010	
	<b>147.93</b>	5.1	<b>1.2</b>	2030	6.1	<b>1.4</b>	1980	9.8	<b>2.13</b>	1930	19.6	<b>4.1</b>	1850	4010	
	<b>158.60</b>	4.7	<b>1.1</b>	2040	5.7	<b>1.3</b>	2020	9.1	<b>2.03</b>	1960	18.3	<b>3.9</b>	1890	4010	
	<b>184.62</b>	4.1	<b>0.97</b>	2100	4.9	<b>1.1</b>	2050	7.9	<b>1.73</b>	1950	15.7	<b>3.3</b>	1870	4010	
	<b>197.93</b>	3.8	<b>0.63</b>	1460	4.5	<b>0.74</b>	1450	7.3	<b>1.17</b>	1410	14.7	<b>2.2</b>	1360	4010	
	<b>230.40</b>	3.3	<b>0.63</b>	1700	3.9	<b>0.74</b>	1690	6.3	<b>1.17</b>	1640	12.6	<b>2.2</b>	1580	4010	
<b>281.42</b>	2.7	<b>0.53</b>	1750	3.2	<b>0.62</b>	1710	5.2	<b>0.93</b>	1600	10.3	<b>1.8</b>	1540	4010		
<b>RE 244</b>	<b>241.49</b>	3.1	<b>0.92</b>	2570	3.7	<b>1.08</b>	2500	6.0	<b>1.62</b>	2320	12.0	<b>3.0</b>	2190	4010	5 (T) 4 (F)
	<b>295.84</b>	2.5	<b>0.78</b>	2650	3.0	<b>0.91</b>	2570	4.9	<b>1.36</b>	2390	9.8	<b>2.5</b>	2210	4010	
	<b>326.80</b>	2.3	<b>0.71</b>	2690	2.8	<b>0.83</b>	2610	4.4	<b>1.25</b>	2430	8.9	<b>2.3</b>	2230	4010	
	<b>344.36</b>	2.2	<b>0.58</b>	2310	2.6	<b>0.68</b>	2250	4.2	<b>1.02</b>	2090	8.4	<b>1.9</b>	1940	4010	
	<b>400.35</b>	1.9	<b>0.60</b>	2770	2.2	<b>0.70</b>	2690	3.6	<b>1.05</b>	2510	7.2	<b>1.9</b>	2260	4010	
	<b>442.25</b>	1.7	<b>0.55</b>	2810	2.0	<b>0.64</b>	2730	3.3	<b>0.97</b>	2540	6.6	<b>1.7</b>	2290	4010	
	<b>499.63</b>	1.5	<b>0.50</b>	2860	1.8	<b>0.58</b>	2790	2.9	<b>0.87</b>	2590	5.8	<b>1.6</b>	2330	4010	
	<b>551.93</b>	1.4	<b>0.46</b>	2910	1.6	<b>0.53</b>	2830	2.6	<b>0.80</b>	2630	5.3	<b>1.4</b>	2370	4010	
	<b>676.14</b>	1.1	<b>0.39</b>	3000	1.3	<b>0.45</b>	2920	2.1	<b>0.67</b>	2710	4.3	<b>1.2</b>	2440	4010	
	<b>733.18</b>	1.0	<b>0.27</b>	2310	1.2	<b>0.32</b>	2250	2.0	<b>0.49</b>	2140	4.0	<b>0.94</b>	2060	4010	
	<b>843.83</b>	0.89	<b>0.32</b>	3100	1.1	<b>0.37</b>	3020	1.7	<b>0.56</b>	2810	3.4	<b>1.0</b>	2530	4010	
	<b>915.01</b>	0.82	<b>0.23</b>	2390	0.98	<b>0.27</b>	2330	1.6	<b>0.40</b>	2170	3.2	<b>0.77</b>	2090	4010	
	<b>1065.09</b>	0.70	<b>0.22</b>	2740	0.85	<b>0.26</b>	2670	1.4	<b>0.39</b>	2480	2.7	<b>0.70</b>	2230	4010	
	<b>1141.93</b>	0.66	<b>0.19</b>	2470	0.79	<b>0.22</b>	2410	1.3	<b>0.33</b>	2240	2.5	<b>0.62</b>	2110	4010	
	<b>1300.93</b>	0.58	<b>0.15</b>	2210	0.69	<b>0.17</b>	2150	1.1	<b>0.26</b>	2000	2.2	<b>0.47</b>	1800	4010	
	<b>1329.23</b>	0.56	<b>0.19</b>	2830	0.68	<b>0.22</b>	2760	1.1	<b>0.32</b>	2570	2.2	<b>0.58</b>	2310	4010	
	<b>1658.88</b>	0.45	<b>0.11</b>	2060	0.54	<b>0.13</b>	2000	0.87	<b>0.19</b>	1860	1.7	<b>0.36</b>	1770	4010	

	ie	n <sub>1</sub> = 750 RPM			n <sub>1</sub> = 900 RPM			n <sub>1</sub> = 1450 RPM			n <sub>1</sub> = 2900 RPM			T <sub>2max</sub> [Nm]	P <sub>t</sub> [kW]
		n <sub>2</sub> [RPM]	P <sub>1</sub> [kW]	T <sub>2</sub> [Nm]	n <sub>2</sub> [RPM]	P <sub>1</sub> [kW]	T <sub>2</sub> [Nm]	n <sub>2</sub> [RPM]	P <sub>1</sub> [kW]	T <sub>2</sub> [Nm]	n <sub>2</sub> [RPM]	P <sub>1</sub> [kW]	T <sub>2</sub> [Nm]		
<b>RA 242</b>	<b>12.22</b>	61	<b>7.1</b>	1030	74	<b>8.4</b>	1020	119	<b>12.4</b>	940	237	<b>20.2</b>	760	2640	6 (T) 4 (F)
	<b>14.22</b>	53	<b>7.1</b>	1200	63	<b>8.4</b>	1190	102	<b>12.4</b>	1090	204	<b>20.2</b>	880	3080	
	<b>17.37</b>	43.2	<b>6.9</b>	1420	52	<b>8.1</b>	1400	83	<b>12.4</b>	1330	167	<b>20.2</b>	1080	3710	
<b>RA 243</b>	<b>42.52</b>	17.6	<b>4.3</b>	2140	21.2	<b>5.1</b>	2120	34.1	<b>8.1</b>	2060	68	<b>15.5</b>	1980	3710	5 (T) 4 (F)
	<b>49.49</b>	15.2	<b>3.3</b>	1880	18.2	<b>3.9</b>	1860	29.3	<b>6.1</b>	1810	59	<b>11.7</b>	1740	3710	
	<b>52.09</b>	14.4	<b>3.6</b>	2170	17.3	<b>4.2</b>	2140	27.8	<b>6.7</b>	2090	56	<b>12.8</b>	2000	3710	
	<b>60.63</b>	12.4	<b>2.7</b>	1900	14.8	<b>3.2</b>	1880	23.9	<b>5.0</b>	1830	47.8	<b>9.7</b>	1760	3710	
	<b>70.49</b>	10.6	<b>2.4</b>	1950	12.8	<b>2.8</b>	1930	20.6	<b>4.4</b>	1880	41.1	<b>8.5</b>	1800	3710	
	<b>82.05</b>	9.1	<b>2.0</b>	1930	11.0	<b>2.4</b>	1910	17.7	<b>3.8</b>	1860	35.3	<b>7.3</b>	1790	3710	
	<b>87.97</b>	8.5	<b>1.4</b>	1400	10.2	<b>1.6</b>	1380	16.5	<b>2.5</b>	1350	33.0	<b>4.9</b>	1290	3610	
	<b>102.40</b>	7.3	<b>1.4</b>	1630	8.8	<b>1.6</b>	1610	14.2	<b>2.5</b>	1570	28.3	<b>4.9</b>	1510	3710	
	<b>125.07</b>	6.0	<b>1.1</b>	1590	7.2	<b>1.3</b>	1570	11.6	<b>2.0</b>	1530	23.2	<b>3.9</b>	1470	3710	
<b>RA 244</b>	<b>147.97</b>	5.1	<b>1.4</b>	2380	6.1	<b>1.7</b>	2320	9.8	<b>2.6</b>	2210	19.6	<b>4.9</b>	2130	3710	4 (T) 3 (F)
	<b>172.24</b>	4.4	<b>1.1</b>	2080	5.2	<b>1.2</b>	2020	8.4	<b>1.9</b>	1940	16.8	<b>3.7</b>	1870	3710	
	<b>181.27</b>	4.1	<b>1.2</b>	2460	5.0	<b>1.4</b>	2390	8.0	<b>2.1</b>	2240	16.0	<b>4.1</b>	2150	3710	
	<b>211.00</b>	3.6	<b>0.90</b>	2150	4.3	<b>1.0</b>	2090	6.9	<b>1.6</b>	1970	13.7	<b>3.1</b>	1890	3710	
	<b>222.06</b>	3.4	<b>1.0</b>	2530	4.1	<b>1.2</b>	2460	6.5	<b>1.8</b>	2290	13.1	<b>3.3</b>	2180	3710	
	<b>245.30</b>	3.1	<b>0.93</b>	2570	3.7	<b>1.1</b>	2500	5.9	<b>1.6</b>	2330	11.8	<b>3.0</b>	2190	3710	
	<b>285.54</b>	2.6	<b>0.69</b>	2250	3.2	<b>0.81</b>	2190	5.1	<b>1.2</b>	2030	10.2	<b>2.3</b>	1920	3710	
	<b>306.14</b>	2.4	<b>0.77</b>	2660	2.9	<b>0.89</b>	2590	4.7	<b>1.3</b>	2410	9.5	<b>2.5</b>	2220	3710	
	<b>375.03</b>	2.0	<b>0.65</b>	2740	2.4	<b>0.75</b>	2670	3.9	<b>1.1</b>	2480	7.7	<b>2.0</b>	2240	3710	
	<b>406.67</b>	1.8	<b>0.47</b>	2150	2.2	<b>0.55</b>	2130	3.6	<b>0.87</b>	2070	7.1	<b>1.7</b>	1990	3710	
	<b>436.55</b>	1.7	<b>0.48</b>	2400	2.1	<b>0.57</b>	2330	3.3	<b>0.85</b>	2170	6.6	<b>1.5</b>	1970	3710	
	<b>507.52</b>	1.5	<b>0.38</b>	2190	1.8	<b>0.45</b>	2160	2.9	<b>0.71</b>	2100	5.7	<b>1.4</b>	2020	3710	
	<b>590.77</b>	1.3	<b>0.37</b>	2510	1.5	<b>0.44</b>	2440	2.5	<b>0.66</b>	2270	4.9	<b>1.2</b>	2040	3710	
	<b>633.39</b>	1.2	<b>0.22</b>	1560	1.4	<b>0.26</b>	1550	2.3	<b>0.41</b>	1510	4.6	<b>0.78</b>	1450	3610	
	<b>721.58</b>	1.0	<b>0.25</b>	2020	1.2	<b>0.29</b>	1970	2.0	<b>0.43</b>	1830	4.0	<b>0.78</b>	1650	3710	
	<b>900.53</b>	0.8	<b>0.21</b>	2090	1.0	<b>0.24</b>	2040	1.6	<b>0.36</b>	1890	3.2	<b>0.65</b>	1710	3710	

# RE 310



	ie	n <sub>1</sub> = 750 RPM			n <sub>1</sub> = 900 RPM			n <sub>1</sub> = 1450 RPM			n <sub>1</sub> = 2900 RPM			T <sub>2max</sub> [Nm]	P <sub>t</sub> [kW]		
		n <sub>2</sub> [RPM]	P <sub>1</sub> [kW]	T <sub>2</sub> [Nm]	n <sub>2</sub> [RPM]	P <sub>1</sub> [kW]	T <sub>2</sub> [Nm]	n <sub>2</sub> [RPM]	P <sub>1</sub> [kW]	T <sub>2</sub> [Nm]	n <sub>2</sub> [RPM]	P <sub>1</sub> [kW]	T <sub>2</sub> [Nm]				
<b>RE 311</b>	<b>3.60</b>	208	<b>43.9</b>	1960	250	<b>49.9</b>	1860	403	<b>70</b>	1610	806	<b>113</b>	1310	4320	18 (N) 22 (T) 13 (F) 36 (P)		
	<b>4.25</b>	176	<b>38.5</b>	2030	212	<b>43.8</b>	1920	341	<b>61</b>	1670	682	<b>99</b>	1350	5630			
	<b>5.33</b>	141	<b>25.3</b>	1680	169	<b>30.1</b>	1660	272	<b>47.1</b>	1610	544	<b>82</b>	1410	4610			
	<b>6.20</b>	121	<b>18.4</b>	1410	145	<b>21.8</b>	1400	234	<b>34.2</b>	1360	468	<b>66</b>	1310	3900			
	<b>7.50</b>	100	<b>11.9</b>	1110	120	<b>14.2</b>	1100	193	<b>22.2</b>	1070	387	<b>42.7</b>	1030	3070			
<b>RE 312</b>	<b>12.53</b>	60	<b>14.9</b>	2260	72	<b>17.3</b>	2180	116	<b>24.1</b>	1890	231	<b>39.2</b>	1540	4320	10 (N) 12 (T) 8 (F) 21 (P)		
	<b>14.79</b>	51	<b>12.3</b>	2200	61	<b>14.6</b>	2180	98	<b>22.9</b>	2120	196	<b>39.2</b>	1810	5630			
	<b>15.35</b>	48.9	<b>12.3</b>	2280	59	<b>14.6</b>	2260	94	<b>20.6</b>	1980	189	<b>33.5</b>	1610	4320			
	<b>18.12</b>	41.4	<b>10.2</b>	2230	49.7	<b>12.1</b>	2210	80	<b>18.9</b>	2150	160	<b>33.5</b>	1900	5630			
	<b>20.77</b>	36.1	<b>6.8</b>	1720	43.3	<b>8.1</b>	1700	70	<b>12.7</b>	1650	140	<b>24.5</b>	1590	4320			
	<b>22.74</b>	33.0	<b>6.6</b>	1820	39.6	<b>7.9</b>	1800	64	<b>12.3</b>	1750	128	<b>23.7</b>	1690	4610			
	<b>24.52</b>	30.6	<b>6.8</b>	2030	36.7	<b>8.1</b>	2010	59	<b>12.7</b>	1950	118	<b>24.5</b>	1880	5960			
	<b>26.43</b>	28.4	<b>4.8</b>	1540	34.1	<b>5.7</b>	1520	55	<b>8.9</b>	1480	110	<b>17.2</b>	1420	3900			
	<b>30.77</b>	24.4	<b>5.0</b>	1850	29.3	<b>5.9</b>	1830	47.1	<b>9.3</b>	1780	94	<b>17.8</b>	1720	4610			
	<b>35.77</b>	21.0	<b>3.6</b>	1560	25.2	<b>4.3</b>	1550	40.5	<b>6.7</b>	1510	81	<b>12.9</b>	1450	3900			
	<b>38.40</b>	19.5	<b>3.9</b>	1830	23.4	<b>4.7</b>	1810	37.8	<b>7.3</b>	1760	76	<b>14.1</b>	1690	4610			
	<b>44.64</b>	16.8	<b>2.9</b>	1580	20.2	<b>3.5</b>	1570	32.5	<b>5.5</b>	1520	65	<b>10.5</b>	1470	3900			
	<b>54.00</b>	13.9	<b>1.9</b>	1240	16.7	<b>2.3</b>	1230	26.9	<b>3.5</b>	1200	54	<b>6.8</b>	1150	3070			
	<b>RE 313</b>	<b>43.60</b>	17.2	<b>4.7</b>	2420	20.6	<b>5.6</b>	2400	33.3	<b>8.8</b>	2330	67	<b>16.8</b>	2230		4320	8 (N) 9 (T) 6 (F) 15 (P)
		<b>51.47</b>	14.6	<b>3.9</b>	2370	17.5	<b>4.6</b>	2340	28.2	<b>7.3</b>	2280	56	<b>13.9</b>	2190		5630	
<b>53.41</b>		14.0	<b>3.9</b>	2450	16.9	<b>4.6</b>	2430	27.1	<b>7.2</b>	2360	54	<b>13.9</b>	2270	4320			
<b>63.05</b>		11.9	<b>3.2</b>	2390	14.3	<b>3.8</b>	2370	23.0	<b>6.0</b>	2310	46.0	<b>11.5</b>	2220	5630			
<b>72.28</b>		10.4	<b>2.9</b>	2500	12.5	<b>3.5</b>	2470	20.1	<b>5.4</b>	2400	40.1	<b>10.5</b>	2310	4320			
<b>77.24</b>		9.7	<b>2.7</b>	2420	11.7	<b>3.2</b>	2400	18.8	<b>4.9</b>	2330	37.5	<b>9.5</b>	2240	5630			
<b>85.33</b>		8.8	<b>2.4</b>	2440	10.5	<b>2.9</b>	2410	17.0	<b>4.5</b>	2350	34.0	<b>8.7</b>	2250	5630			
<b>104.53</b>		7.2	<b>2.0</b>	2510	8.6	<b>2.4</b>	2440	13.9	<b>3.7</b>	2370	27.7	<b>7.2</b>	2280	5630			
<b>106.49</b>		7.0	<b>2.0</b>	2510	8.5	<b>2.3</b>	2440	13.6	<b>3.7</b>	2380	27.2	<b>7.0</b>	2280	5630			
<b>130.45</b>		5.7	<b>1.7</b>	2590	6.9	<b>2.0</b>	2520	11.1	<b>3.0</b>	2400	22.2	<b>5.8</b>	2310	5630			
<b>141.46</b>		5.3	<b>1.3</b>	2240	6.4	<b>1.6</b>	2220	10.3	<b>2.5</b>	2160	20.5	<b>4.8</b>	2080	5960			
<b>163.71</b>		4.6	<b>1.1</b>	2100	5.5	<b>1.3</b>	2050	8.9	<b>2.0</b>	1960	17.7	<b>3.8</b>	1890	4610			
<b>176.54</b>		4.2	<b>1.1</b>	2270	5.1	<b>1.3</b>	2250	8.2	<b>2.0</b>	2190	16.4	<b>3.9</b>	2100	5960			
<b>190.31</b>		3.9	<b>0.79</b>	1770	4.7	<b>0.92</b>	1720	7.6	<b>1.4</b>	1660	15.2	<b>2.7</b>	1590	3900			
<b>221.54</b>		3.4	<b>0.84</b>	2200	4.1	<b>0.98</b>	2140	6.5	<b>1.5</b>	2000	13.1	<b>2.8</b>	1920	4610			
<b>257.54</b>		2.9	<b>0.61</b>	1850	3.5	<b>0.71</b>	1800	5.6	<b>1.1</b>	1680	11.3	<b>2.1</b>	1620	3900			
<b>276.48</b>		2.7	<b>0.63</b>	2040	3.3	<b>0.74</b>	2020	5.2	<b>1.2</b>	1970	10.5	<b>2.2</b>	1890	4610			
<b>321.41</b>		2.3	<b>0.50</b>	1920	2.8	<b>0.59</b>	1860	4.5	<b>0.88</b>	1730	9.0	<b>1.7</b>	1640	3900			
<b>RE 314</b>	<b>219.42</b>	3.4	<b>1.1</b>	2800	4.1	<b>1.30</b>	2730	6.6	<b>1.9</b>	2540	13.2	<b>3.6</b>	2380	5630	6 (N) 7 (T) 5 (F) 12 (P)		
	<b>268.80</b>	2.8	<b>0.93</b>	2890	3.3	<b>1.09</b>	2810	5.4	<b>1.6</b>	2620	10.8	<b>3.0</b>	2410	5630			
	<b>296.94</b>	2.5	<b>0.86</b>	2930	3.0	<b>1.00</b>	2850	4.9	<b>1.5</b>	2660	9.8	<b>2.7</b>	2420	5630			
	<b>329.29</b>	2.3	<b>0.79</b>	2980	2.7	<b>0.92</b>	2900	4.4	<b>1.4</b>	2700	8.8	<b>2.5</b>	2440	5630			
	<b>363.76</b>	2.1	<b>0.72</b>	3030	2.5	<b>0.84</b>	2940	4.0	<b>1.3</b>	2740	8.0	<b>2.3</b>	2470	5630			
	<b>416.98</b>	1.8	<b>0.61</b>	2930	2.2	<b>0.71</b>	2850	3.5	<b>1.1</b>	2680	7.0	<b>2.1</b>	2580	4320			
	<b>453.98</b>	1.7	<b>0.60</b>	3130	2.0	<b>0.70</b>	3040	3.2	<b>1.0</b>	2830	6.4	<b>1.9</b>	2550	5630			
	<b>492.27</b>	1.5	<b>0.56</b>	3170	1.8	<b>0.65</b>	3080	2.9	<b>0.98</b>	2870	5.9	<b>1.8</b>	2580	5630			
	<b>556.14</b>	1.3	<b>0.50</b>	3230	1.6	<b>0.59</b>	3140	2.6	<b>0.88</b>	2920	5.2	<b>1.6</b>	2630	5630			
	<b>614.35</b>	1.2	<b>0.46</b>	3280	1.5	<b>0.54</b>	3190	2.4	<b>0.81</b>	2960	4.7	<b>1.5</b>	2670	5630			
	<b>766.71</b>	0.98	<b>0.38</b>	3390	1.2	<b>0.45</b>	3290	1.9	<b>0.67</b>	3070	3.8	<b>1.2</b>	2760	5630			
	<b>795.61</b>	0.94	<b>0.35</b>	3190	1.1	<b>0.41</b>	3100	1.8	<b>0.61</b>	2880	3.6	<b>1.1</b>	2700	4320			
	<b>939.26</b>	0.80	<b>0.32</b>	3490	0.96	<b>0.38</b>	3400	1.5	<b>0.57</b>	3160	3.1	<b>1.0</b>	2850	5630			
	<b>1018.49</b>	0.74	<b>0.23</b>	2660	0.88	<b>0.27</b>	2590	1.4	<b>0.40</b>	2420	2.8	<b>0.77</b>	2320	5960			
	<b>1178.68</b>	0.64	<b>0.21</b>	2840	0.76	<b>0.24</b>	2760	1.2	<b>0.37</b>	2570	2.5	<b>0.66</b>	2310	4610			
	<b>1271.08</b>	0.59	<b>0.19</b>	2750	0.71	<b>0.22</b>	2680	1.1	<b>0.33</b>	2490	2.3	<b>0.62</b>	2350	5960			
	<b>1595.08</b>	0.47	<b>0.16</b>	2970	0.56	<b>0.19</b>	2890	0.91	<b>0.28</b>	2690	1.8	<b>0.51</b>	2420	4610			
	<b>1990.66</b>	0.38	<b>0.11</b>	2470	0.45	<b>0.13</b>	2400	0.73	<b>0.19</b>	2230	1.5	<b>0.36</b>	2120	4610			

	ie	n <sub>1</sub> = 750 RPM			n <sub>1</sub> = 900 RPM			n <sub>1</sub> = 1450 RPM			n <sub>1</sub> = 2900 RPM			T <sub>2max</sub> [Nm]	P <sub>t</sub> [kW]
		n <sub>2</sub> [RPM]	P <sub>1</sub> [kW]	T <sub>2</sub> [Nm]	n <sub>2</sub> [RPM]	P <sub>1</sub> [kW]	T <sub>2</sub> [Nm]	n <sub>2</sub> [RPM]	P <sub>1</sub> [kW]	T <sub>2</sub> [Nm]	n <sub>2</sub> [RPM]	P <sub>1</sub> [kW]	T <sub>2</sub> [Nm]		
RA 312	10.03	75	18.6	2230	90	22.1	2200	145	34.7	2150	289	58	1780	4320	10 (N) 12 (T) 8 (F) 17 (P)
	11.84	63	15.4	2180	76	18.3	2150	122	28.7	2100	245	50	1840	5630	
	14.40	52	13.3	2270	63	15.7	2250	101	24.7	2190	201	44.7	1980	4320	
	17.00	44.1	11.0	2220	53	13.0	2200	85	20.4	2140	171	39.2	2050	5630	
	21.33	35.2	7.1	1810	42.2	8.5	1800	68	13.3	1750	136	25.5	1680	4610	
	24.80	30.2	5.2	1530	36.3	6.1	1510	58	9.6	1470	117	18.5	1420	3900	
	30.00	25.0	3.4	1200	30.0	4.0	1190	48.3	6.3	1160	97	12.0	1110	3070	
RA 313	40.09	18.7	5.2	2410	22.4	6.1	2390	36.2	9.6	2320	72	18.1	2180	4320	6 (N) 7 (T) 5 (F) 11 (P)
	47.33	15.8	4.3	2360	19.0	5.1	2330	30.6	8.0	2270	61	15.3	2180	5630	
	49.11	15.3	4.3	2440	18.3	5.1	2410	29.5	8.0	2350	59	15.3	2260	4320	
	57.98	12.9	3.5	2380	15.5	4.2	2360	25.0	6.6	2290	50	12.7	2210	5630	
	66.46	11.3	2.4	1840	13.5	2.8	1820	21.8	4.4	1770	43.6	8.5	1700	4730	
	72.76	10.3	2.3	1950	12.4	2.7	1930	19.9	4.3	1870	39.9	8.2	1800	4610	
	78.46	9.6	2.4	2170	11.5	2.8	2150	18.5	4.4	2090	37.0	8.5	2010	5590	
	84.58	8.9	1.7	1640	10.6	2.0	1620	17.1	3.1	1580	34.3	6.0	1520	3900	
	98.46	7.6	1.7	1980	9.1	2.1	1960	14.7	3.2	1910	29.5	6.2	1830	4610	
	114.46	6.6	1.3	1670	7.9	1.5	1650	12.7	2.3	1610	25.3	4.5	1550	3900	
	122.88	6.1	1.4	1950	7.3	1.6	1930	11.8	2.5	1880	23.6	4.9	1810	4610	
	142.85	5.3	1.0	1690	6.3	1.2	1670	10.2	1.9	1630	20.3	3.6	1570	3900	
172.80	4.3	0.66	1330	5.2	0.79	1320	8.4	1.23	1280	16.8	2.37	1230	3070		
RA 314	139.51	5.4	1.7	2620	6.5	2.0	2590	10.4	3.1	2500	20.8	5.9	2400	4320	5 (N) 6 (T) 4 (F) 10 (P)
	164.70	4.6	1.4	2680	5.5	1.7	2610	8.8	2.5	2440	17.6	4.9	2340	5630	
	170.91	4.4	1.4	2680	5.3	1.6	2650	8.5	2.6	2580	17.0	4.8	2430	4320	
	201.77	3.7	1.2	2770	4.5	1.4	2690	7.2	2.1	2500	14.4	4.0	2370	5630	
	231.29	3.2	1.0	2690	3.9	1.2	2670	6.3	1.9	2590	13.9	3.6	2470	4320	
	247.17	3.0	1.0	2850	3.6	1.2	2780	5.9	1.8	2580	11.7	3.3	2400	5630	
	273.05	2.7	0.94	2900	3.3	1.1	2820	5.3	1.6	2620	10.6	3.0	2410	5630	
	310.18	2.4	0.66	2320	2.9	0.77	2250	4.7	1.15	2100	9.3	2.15	1960	4610	
	340.76	2.2	0.78	3000	2.6	0.91	2910	4.3	1.36	2710	8.5	2.45	2440	5630	
	417.45	1.8	0.65	3090	2.2	0.76	3010	3.5	1.14	2800	6.9	2.06	2520	5630	
	452.66	1.7	0.47	2400	2.0	0.55	2370	3.2	0.87	2310	6.4	1.67	2220	5590	
	497.11	1.5	0.36	2050	1.8	0.42	1990	2.9	0.64	1850	5.8	1.15	1680	3900	
	564.92	1.3	0.38	2430	1.6	0.45	2400	2.6	0.71	2340	5.1	1.36	2250	5590	
	608.98	1.2	0.31	2110	1.5	0.36	2050	2.4	0.54	1910	4.8	0.96	1720	3900	
	708.92	1.1	0.33	2630	1.3	0.38	2560	2.0	0.57	2380	4.1	1.03	2140	4610	
	824.12	0.91	0.24	2210	1.1	0.28	2150	1.8	0.41	2000	3.5	0.75	1800	3900	
	884.74	0.85	0.22	2190	1.0	0.26	2160	1.6	0.41	2100	3.3	0.78	2020	4610	
	1028.51	0.73	0.20	2280	0.88	0.23	2220	1.4	0.34	2070	2.8	0.62	1860	3900	
1244.16	0.60	0.13	1790	0.72	0.15	1740	1.2	0.22	1620	2.3	0.40	1460	3070		

	ie	n <sub>1</sub> = 750 RPM			n <sub>1</sub> = 900 RPM			n <sub>1</sub> = 1450 RPM			n <sub>1</sub> = 2900 RPM			T <sub>2max</sub> [Nm]	P <sub>t</sub> [kW]
		n <sub>2</sub> [RPM]	P <sub>1</sub> [kW]	T <sub>2</sub> [Nm]	n <sub>2</sub> [RPM]	P <sub>1</sub> [kW]	T <sub>2</sub> [Nm]	n <sub>2</sub> [RPM]	P <sub>1</sub> [kW]	T <sub>2</sub> [Nm]	n <sub>2</sub> [RPM]	P <sub>1</sub> [kW]	T <sub>2</sub> [Nm]		
RE 511	3.60	208	76	3400	250	86	3220	403	121	2790	806	196	2260	11600	19 (N) 24 (T) 14 (F) 37 (P)
	4.25	176	67	3520	212	76	3330	341	106	2890	682	172	2340	11600	
	5.33	141	52	3450	169	62	3420	272	88	3010	544	143	2440	9500	
	6.20	121	37.9	2920	145	45.1	2890	234	71	2810	468	127	2530	8050	
	7.50	100	24.6	2290	120	29.2	2260	193	45.8	2200	387	88	2120	6320	
RE 512	12.53	60	27.2	4120	72	30.9	3900	116	43.1	3380	231	70	2750	11600	11 (N) 13 (T) 8 (F) 21 (P)
	14.79	51	25.4	4540	61	30.1	4500	98	43.1	3990	196	70	3240	11600	
	15.35	48.9	23.2	4320	59	26.4	4090	94	36.9	3540	189	60	2880	11600	
	18.12	41.4	21.0	4600	49.7	24.9	4550	80	36.9	4180	160	60	3400	11600	
	20.77	36.1	13.8	3470	43.3	16.4	3430	70	25.7	3340	140	46.9	3050	9540	
	22.74	33.0	13.6	3750	39.6	16.2	3710	64	25.4	3610	128	48.8	3470	9500	
	24.52	30.6	13.8	4090	36.7	16.4	4050	59	25.7	3940	118	46.9	3600	11300	
	26.43	28.4	9.9	3170	34.1	11.8	3140	55	18.5	3060	110	35.5	2940	8050	
	30.77	24.4	10.2	3820	29.3	12.2	3780	47.1	19.1	3680	94	36.7	3530	9500	
	35.77	21.0	7.5	3230	25.2	8.9	3190	40.5	13.9	3110	81	26.7	2990	8050	
	38.40	19.5	8.0	3700	23.4	9.4	3660	37.8	14.8	3560	76	28.5	3420	9500	
	44.64	16.8	6.0	3270	20.2	7.2	3230	32.5	11.3	3150	65	21.7	3030	8050	
	54.00	13.9	3.9	2560	16.7	4.7	2530	26.9	7.3	2470	54	14.0	2370	6320	
RE 513	43.60	17.2	9.5	4870	20.6	11.2	4820	33.3	17.6	4690	67	30.0	3990	11600	8 (N) 10 (T) 6 (F) 15 (P)
	51.47	14.6	8.0	4880	17.5	9.5	4830	28.2	15.0	4700	56	28.7	4520	11600	
	53.41	14.0	7.8	4920	16.9	9.3	4870	27.1	14.5	4740	54	25.7	4180	11600	
	63.05	11.9	6.6	4940	14.3	7.9	4880	23.0	12.3	4750	46.0	23.7	4570	11600	
	72.28	10.4	5.9	5020	12.5	7.0	4960	20.1	10.9	4820	40.1	21.0	4640	11600	
	77.24	9.7	5.5	4990	11.7	6.5	4940	18.8	10.2	4810	37.5	19.6	4620	11600	
	85.33	8.8	5.0	5020	10.5	5.9	4970	17.0	9.3	4840	34.0	17.8	4650	11600	
	104.53	7.2	4.2	5160	8.6	4.9	5030	13.9	7.7	4890	27.7	14.7	4700	11600	
	110.50	6.8	4.0	5220	8.1	4.8	5170	13.1	7.3	4940	26.2	14.1	4750	11600	
	130.45	5.7	3.5	5340	6.9	4.0	5200	11.1	6.2	4960	22.2	12.0	4760	11600	
	141.46	5.3	2.7	4520	6.4	3.2	4480	10.3	5.0	4360	20.5	9.7	4190	11300	
	163.71	4.6	2.2	4330	5.5	2.6	4220	8.9	4.0	4040	17.7	7.8	3890	9500	
	176.54	4.2	2.2	4580	5.1	2.6	4530	8.2	4.1	4410	16.4	7.9	4240	11300	
	190.31	3.9	1.6	3650	4.7	1.9	3550	7.6	2.9	3420	15.2	5.7	3290	8050	
	221.54	3.4	1.7	4540	4.1	2.0	4410	6.5	3.0	4120	13.1	5.8	3960	9500	
	257.54	2.9	1.3	3830	3.5	1.5	3720	5.6	2.2	3480	11.3	4.3	3340	8050	
276.48	2.7	1.3	4140	3.3	1.5	4100	5.2	2.4	3990	10.5	4.5	3830	9500		
321.41	2.3	1.0	3960	2.8	1.2	3850	4.5	1.8	3580	9.0	3.5	3390	8050		
RE 514	219.42	3.4	2.3	5780	4.1	2.7	5620	6.6	4.0	5230	13.2	7.5	4910	11600	7 (N) 8 (T) 5 (F) 12 (P)
	268.80	2.8	1.9	5960	3.3	2.2	5800	5.4	3.4	5390	10.8	6.2	4960	11600	
	296.94	2.5	1.8	6050	3.0	2.1	5880	4.9	3.1	5470	9.8	5.6	4990	11600	
	329.29	2.3	1.6	6140	2.7	1.9	5980	4.4	2.8	5560	8.8	5.1	5020	11600	
	363.76	2.1	1.5	6240	2.5	1.7	6070	4.0	2.6	5650	8.0	4.7	5080	11600	
	416.98	1.8	1.3	6100	2.2	1.5	5940	3.5	2.2	5580	7.0	4.3	5340	11600	
	453.98	1.7	1.2	6450	2.0	1.4	6270	3.2	2.2	5840	6.4	3.9	5260	11600	
	492.27	1.5	1.2	6530	1.8	1.3	6350	2.9	2.0	5910	5.9	3.6	5320	11600	
	556.14	1.3	1.0	6650	1.6	1.2	6470	2.6	1.8	6020	5.2	3.3	5420	11600	
	614.35	1.2	0.96	6750	1.5	1.1	6570	2.4	1.7	6110	4.7	3.0	5500	11600	
	766.71	0.98	0.64	5670	1.2	0.76	5610	1.9	1.2	5460	3.8	2.3	5250	11600	
	939.26	0.80	0.64	6950	0.96	0.76	6880	1.5	1.2	6520	3.1	2.1	5870	11600	
	1018.49	0.74	0.46	5370	0.88	0.53	5220	1.4	0.80	4880	2.8	1.5	4690	11300	
	1178.68	0.64	0.43	5840	0.76	0.50	5680	1.2	0.75	5290	2.5	1.4	4760	9500	
	1271.08	0.59	0.38	5550	0.71	0.44	5400	1.1	0.66	5030	2.3	1.3	4750	11300	
	1595.08	0.47	0.33	6120	0.56	0.39	5950	0.91	0.58	5540	1.8	1.1	4990	9500	
	1854.28	0.40	0.24	5160	0.49	0.28	5020	0.78	0.42	4670	1.6	0.76	4200	8050	
	1990.66	0.38	0.22	5000	0.45	0.25	4860	0.73	0.38	4520	1.5	0.72	4290	9500	

	ie	n <sub>1</sub> = 750 RPM			n <sub>1</sub> = 900 RPM			n <sub>1</sub> = 1450 RPM			n <sub>1</sub> = 2900 RPM			T <sub>2max</sub> [Nm]	P <sub>t</sub> [kW]
		n <sub>2</sub> [RPM]	P <sub>1</sub> [kW]	T <sub>2</sub> [Nm]	n <sub>2</sub> [RPM]	P <sub>1</sub> [kW]	T <sub>2</sub> [Nm]	n <sub>2</sub> [RPM]	P <sub>1</sub> [kW]	T <sub>2</sub> [Nm]	n <sub>2</sub> [RPM]	P <sub>1</sub> [kW]	T <sub>2</sub> [Nm]		
RA 512	10.03	75	27.1	3240	90	30.8	3070	145	43.0	2660	289	70	2160	11600	10 (N) 12 (T) 9 (F) 17 (P)
	11.84	63	27.1	3820	76	30.8	3620	122	43.0	3140	245	70	2550	11600	
	14.40	52	20.0	3440	63	22.8	3260	101	31.8	2820	201	51.7	2290	10000	
	17.00	44.1	20.0	4060	53	22.8	3840	85	31.8	3330	171	51.7	2710	11600	
	20.89	35.9	9.7	2430	43.1	11.6	2400	69	18.1	2340	139	34.9	2250	6320	
	21.33	35.2	14.7	3740	42.2	17.5	3700	68	27.4	3600	136	51.7	3400	9500	
	24.80	30.2	10.7	3160	36.3	12.7	3130	58	19.9	3040	117	38.3	2930	8050	
	30.00	25.0	6.9	2480	30.0	8.2	2450	48.3	12.9	2390	97	24.8	2290	6320	
RA 513	40.09	18.7	7.3	3390	22.4	8.6	3350	36.2	12.7	3070	72	20.7	2490	8660	7 (N) 9 (T) 5 (F) 12 (P)
	47.33	15.8	7.3	4000	19.0	8.6	3960	30.6	12.7	3630	61	20.7	2950	10300	
	49.11	15.3	7.3	4150	18.3	8.6	4110	29.5	12.7	3760	59	20.7	3060	10700	
	57.98	12.9	7.3	4900	15.5	8.6	4850	25.0	12.7	4440	50	20.7	3610	11600	
	66.46	11.3	4.8	3710	13.5	5.7	3670	21.8	8.9	3570	43.6	17.2	3430	9540	
	72.76	10.3	4.7	4010	12.4	5.6	3970	19.9	8.8	3860	39.9	17.0	3710	9500	
	78.46	9.6	4.8	4370	11.5	5.7	4330	18.5	8.9	4210	37.0	17.2	4050	11300	
	84.58	8.9	3.4	3390	10.6	4.1	3360	17.1	6.4	3270	34.3	12.3	3140	8050	
	98.46	7.6	3.6	4080	9.1	4.2	4040	14.7	6.6	3930	29.5	12.8	3780	9500	
	114.46	6.6	2.6	3450	7.9	3.1	3410	12.7	4.8	3320	25.3	9.3	3190	8050	
	122.88	6.1	2.8	3950	7.3	3.3	3910	11.8	5.2	3810	23.6	9.9	3660	9500	
	142.85	5.3	2.1	3500	6.3	2.5	3460	10.2	3.9	3360	20.3	7.5	3230	8050	
172.80	4.3	1.4	2740	5.2	1.6	2710	8.4	2.5	2640	16.8	4.9	2530	6320		
RA 514	139.51	5.4	3.4	5440	6.5	4.1	5390	10.4	6.1	5020	20.8	11.8	4810	11600	6 (N) 7 (T) 5 (F) 11 (P)
	164.70	4.6	3.0	5530	5.5	3.5	5380	8.8	5.2	5020	17.6	10.0	4830	11600	
	170.91	4.4	2.8	5350	5.3	3.3	5300	8.5	5.1	5150	17.0	9.7	4870	11600	
	201.77	3.7	2.5	5710	4.5	2.9	5550	7.2	4.4	5160	14.4	8.3	4880	11600	
	231.29	3.2	2.1	5600	3.9	2.5	5540	6.3	4.0	5400	12.5	7.3	4950	11600	
	247.17	3.0	2.1	5880	3.6	2.5	5720	5.9	3.7	5320	11.7	6.8	4940	11600	
	273.05	2.7	1.9	5970	3.3	2.3	5810	5.3	3.4	5410	10.6	6.2	4970	11600	
	310.18	2.4	1.4	4770	2.9	1.6	4640	4.7	2.4	4320	9.3	4.4	4030	9500	
	340.76	2.2	1.4	5410	2.6	1.7	5360	4.3	2.6	5210	8.5	5.0	5010	11600	
	417.45	1.8	1.3	6370	2.2	1.6	6200	3.5	2.4	5760	6.9	4.2	5190	11600	
	452.66	1.7	0.94	4830	2.0	1.1	4780	3.2	1.8	4660	6.4	3.4	4480	11300	
	497.11	1.5	0.75	4230	1.8	0.88	4110	2.9	1.3	3820	5.8	2.4	3470	8050	
	564.92	1.3	0.77	4910	1.6	0.91	4850	2.6	1.4	4720	5.1	2.7	4530	11300	
	608.98	1.2	0.63	4360	1.5	0.74	4240	2.4	1.1	3940	4.8	2.0	3550	8050	
	708.92	1.1	0.67	5410	1.3	0.79	5260	2.0	1.2	4900	4.1	2.1	4410	9500	
	824.12	0.91	0.49	4560	1.1	0.57	4440	1.8	0.85	4130	3.5	1.5	3720	8050	
	884.74	0.85	0.44	4420	1.0	0.52	4380	1.6	0.82	4260	3.3	1.6	4100	9500	
	1028.51	0.73	0.40	4720	0.88	0.47	4590	1.4	0.71	4270	2.8	1.3	3840	8050	
1244.16	0.60	0.26	3680	0.72	0.31	3580	1.2	0.46	3340	2.3	0.82	3000	6320		

	ie	n <sub>1</sub> = 750 RPM			n <sub>1</sub> = 900 RPM			n <sub>1</sub> = 1450 RPM			n <sub>1</sub> = 2900 RPM			T <sub>2max</sub> [Nm]	P <sub>t</sub> [kW]
		n <sub>2</sub> [RPM]	P <sub>1</sub> [kW]	T <sub>2</sub> [Nm]	n <sub>2</sub> [RPM]	P <sub>1</sub> [kW]	T <sub>2</sub> [Nm]	n <sub>2</sub> [RPM]	P <sub>1</sub> [kW]	T <sub>2</sub> [Nm]	n <sub>2</sub> [RPM]	P <sub>1</sub> [kW]	T <sub>2</sub> [Nm]		
RE 611	4.00	188	93	4630	225	106	4380	363	148	3800	725	240	3080	14900	20 (N) 24 (T) 14 (F) 37 (P)
	4.55	165	84	4730	198	95	4480	319	133	3880	638	216	3160	12860	
RE 612	14.40	52	34.3	5970	63	40.7	5910	101	62	5580	201	100	4530	14900	15 (N) 14 (T) 9 (F) 22 (P)
	16.36	45.8	26.8	5320	55	31.9	5260	89	50	5120	177	90	4630	12860	
	17.00	44.1	29.3	6030	53	34.8	5970	85	55	5810	171	89	4760	14900	
	19.32	38.8	23.0	5370	46.6	27.3	5310	75	42.7	5170	150	81	4870	12860	
	21.33	35.2	23.6	6110	42.2	28.1	6040	68	44.0	5880	136	76	5100	14900	
	24.24	30.9	18.5	5440	37.1	22.0	5380	60	34.5	5240	120	66	5030	12860	
	28.18	26.6	16.1	5490	31.9	19.1	5430	51	29.9	5280	103	58	5080	12860	
	30.00	25.0	12.2	4440	30.0	14.5	4400	48.3	22.8	4280	97	43.8	4110	12300	
34.09	22.0	12.2	5050	26.4	14.5	5000	42.5	22.8	4860	85	43.8	4670	12860		
RE 613	50.11	15.0	10.8	6410	18.0	12.9	6350	28.9	20.2	6180	58	38.8	5940	14900	9 (N) 10 (T) 7 (F) 17 (P)
	56.95	13.2	8.5	5710	15.8	10.1	5650	25.5	15.8	5500	51	30.4	5290	12860	
	61.39	12.2	9.0	6490	14.7	10.6	6420	23.6	16.7	6250	47.2	32.0	6000	14900	
	69.76	10.8	7.0	5780	12.9	8.3	5720	20.8	13.1	5560	41.6	25.1	5350	12860	
	82.36	9.1	6.0	5830	10.9	7.1	5770	17.6	11.2	5620	35.2	21.5	5400	12860	
	90.95	8.2	6.2	6630	9.9	7.3	6570	15.9	11.5	6390	31.9	22.1	6140	14900	
	98.08	7.6	5.8	6660	9.2	6.8	6590	14.8	10.7	6420	29.6	20.6	6170	14900	
	111.45	6.7	4.5	5930	8.1	5.4	5870	13.0	8.4	5710	26.0	16.1	5490	12860	
	123.08	6.1	4.7	6830	7.3	5.5	6680	11.8	8.7	6500	23.6	16.6	6250	14900	
	139.86	5.4	3.7	6060	6.4	4.3	5950	10.4	6.8	5790	20.7	13.0	5560	12860	
	153.60	4.9	3.9	7070	5.9	4.6	6870	9.4	7.0	6580	18.9	13.5	6330	14900	
	174.55	4.3	3.0	6270	5.2	3.6	6100	8.3	5.5	5860	16.6	10.6	5640	12860	
202.91	3.7	2.7	6410	4.4	3.1	6240	7.1	4.8	5910	14.3	9.2	5680	12860		
RE 614	174.39	4.3	3.6	7200	5.2	4.2	7010	8.3	6.4	6630	16.6	12.3	6370	14900	7 (N) 9 (T) 6 (F) 13 (P)
	205.88	3.6	3.1	7390	4.4	3.6	7190	7.0	5.5	6690	14.1	10.5	6430	14900	
	233.95	3.2	2.4	6550	3.8	2.8	6380	6.2	4.3	5960	12.4	8.2	5730	12860	
	252.21	3.0	2.6	7620	3.6	3.1	7410	5.7	4.6	6890	11.5	8.7	6510	14900	
	286.60	2.6	2.0	6760	3.1	2.4	6570	5.1	3.6	6120	10.1	6.8	5800	12860	
	316.50	2.4	2.1	7820	2.8	2.5	7670	4.6	3.8	7140	9.2	7.0	6590	14900	
	354.17	2.1	2.0	8020	2.5	2.3	7800	4.1	3.4	7260	8.2	6.3	6640	14900	
	402.47	1.9	1.5	7110	2.2	1.8	6920	3.6	2.7	6440	7.2	4.9	5910	12860	
	450.73	1.7	1.3	6680	2.0	1.5	6610	3.2	2.4	6430	6.4	4.6	6180	14900	
	502.28	1.5	1.3	7360	1.8	1.5	7160	2.9	2.2	6660	5.8	4.0	6000	12860	
	565.83	1.3	1.3	8610	1.6	1.5	8370	2.6	2.3	7790	5.1	4.2	7020	14900	
	642.99	1.2	1.0	7640	1.4	1.2	7430	2.3	1.8	6910	4.5	3.3	6220	12860	
	706.15	1.1	1.1	8900	1.3	1.3	8660	2.1	1.9	8060	4.1	3.5	7250	14900	
	802.45	0.93	0.86	7900	1.1	1.0	7680	1.8	1.5	7150	3.6	2.7	6440	12860	
	886.15	0.85	0.86	8810	1.0	1.0	8570	1.6	1.5	7990	3.3	2.8	7510	14900	
	1006.99	0.74	0.71	8170	0.89	0.82	7950	1.4	1.2	7400	2.9	2.2	6660	12860	
	1105.92	0.68	0.64	8180	0.81	0.76	8100	1.3	1.2	7880	2.6	2.3	7570	14900	
1256.73	0.60	0.58	8450	0.72	0.68	8220	1.2	1.0	7650	2.3	1.8	6890	12860		
1416.08	0.53	0.40	6590	0.64	0.47	6410	1.0	0.71	6020	2.0	1.4	5780	12860		

	ie	n <sub>1</sub> = 750 RPM			n <sub>1</sub> = 900 RPM			n <sub>1</sub> = 1450 RPM			n <sub>1</sub> = 2900 RPM			T <sub>2max</sub> [Nm]	P <sub>t</sub> [kW]
		n <sub>2</sub> [RPM]	P <sub>1</sub> [kW]	T <sub>2</sub> [Nm]	n <sub>2</sub> [RPM]	P <sub>1</sub> [kW]	T <sub>2</sub> [Nm]	n <sub>2</sub> [RPM]	P <sub>1</sub> [kW]	T <sub>2</sub> [Nm]	n <sub>2</sub> [RPM]	P <sub>1</sub> [kW]	T <sub>2</sub> [Nm]		
<b>RA 612</b>	<b>11.14</b>	67	<b>27.1</b>	3600	81	<b>30.8</b>	3410	130	<b>43.0</b>	2950	260	<b>70</b>	2400	14900	11 (N) 12 (T) 9 (F) 16 (P)
	<b>12.66</b>	59	<b>27.1</b>	4090	71	<b>30.8</b>	3870	115	<b>43.0</b>	3350	229	<b>70</b>	2720	12800	
	<b>16.00</b>	46.9	<b>20.0</b>	3820	56	<b>22.8</b>	3620	91	<b>31.8</b>	3140	181	<b>51.7</b>	2550	11100	
	<b>18.18</b>	41.3	<b>20.0</b>	4340	49.5	<b>22.8</b>	4110	80	<b>31.8</b>	3560	160	<b>51.7</b>	2890	12800	
<b>RA 613</b>	<b>40.11</b>	18.7	<b>13.6</b>	6330	22.4	<b>16.1</b>	6270	36.1	<b>25.3</b>	6100	72	<b>48.6</b>	5860	14900	9 (N) 10 (T) 8 (F) 14 (P)
	<b>45.58</b>	16.5	<b>10.6</b>	5640	19.7	<b>12.6</b>	5580	31.8	<b>19.8</b>	5430	64	<b>38.1</b>	5220	12800	
	<b>47.36</b>	15.8	<b>11.6</b>	6390	19.0	<b>13.8</b>	6330	30.6	<b>21.6</b>	6160	61	<b>41.6</b>	5920	14900	
	<b>57.60</b>	13.0	<b>9.7</b>	6460	15.6	<b>11.5</b>	6400	25.2	<b>18.0</b>	6220	50	<b>34.6</b>	5980	14900	
	<b>65.45</b>	11.5	<b>7.6</b>	5760	13.8	<b>9.0</b>	5700	22.2	<b>14.1</b>	5540	44.3	<b>27.1</b>	5330	12800	
	<b>68.00</b>	11.0	<b>8.3</b>	6530	13.2	<b>9.8</b>	6460	21.3	<b>15.4</b>	6280	42.6	<b>29.6</b>	6040	14900	
	<b>78.51</b>	9.6	<b>6.4</b>	5820	11.5	<b>7.6</b>	5760	18.5	<b>11.9</b>	5600	36.9	<b>22.8</b>	5380	12800	
	<b>85.33</b>	8.8	<b>6.7</b>	6610	10.5	<b>7.9</b>	6540	17.0	<b>12.4</b>	6370	34.0	<b>23.9</b>	6120	14900	
	<b>96.97</b>	7.7	<b>5.2</b>	5890	9.3	<b>6.2</b>	5830	15.0	<b>9.7</b>	5670	29.9	<b>18.7</b>	5450	12800	
	<b>112.73</b>	6.7	<b>4.5</b>	5940	8.0	<b>5.4</b>	5880	12.9	<b>8.4</b>	5720	25.7	<b>16.2</b>	5500	12800	
<b>RA 614</b>	<b>160.36</b>	4.7	<b>3.9</b>	7110	5.6	<b>4.6</b>	6920	9.0	<b>7.0</b>	6600	18.1	<b>13.5</b>	6340	14900	6 (N) 7 (T) 5 (F) 11 (P)
	<b>182.23</b>	4.1	<b>3.1</b>	6310	4.9	<b>3.6</b>	6140	8.0	<b>5.5</b>	5880	15.9	<b>10.6</b>	5650	12800	
	<b>196.45</b>	3.8	<b>3.3</b>	7330	4.6	<b>3.8</b>	7140	7.4	<b>5.8</b>	6680	14.8	<b>11.1</b>	6420	14900	
	<b>231.92</b>	3.2	<b>2.9</b>	7520	3.9	<b>3.3</b>	7320	6.3	<b>5.0</b>	6810	12.5	<b>9.5</b>	6480	14900	
	<b>263.54</b>	2.8	<b>2.2</b>	6670	3.4	<b>2.6</b>	6490	5.5	<b>3.9</b>	6040	11.0	<b>7.5</b>	5770	12800	
	<b>291.03</b>	2.6	<b>2.4</b>	7780	3.1	<b>2.8</b>	7570	5.0	<b>4.1</b>	7050	10.0	<b>7.7</b>	6560	14900	
	<b>313.85</b>	2.4	<b>2.2</b>	7870	2.9	<b>2.6</b>	7660	4.6	<b>3.9</b>	7130	9.2	<b>7.2</b>	6590	14900	
	<b>356.64</b>	2.1	<b>1.7</b>	6990	2.5	<b>2.0</b>	6800	4.1	<b>3.0</b>	6320	8.1	<b>5.6</b>	5870	12800	
	<b>393.85</b>	1.9	<b>1.8</b>	7920	2.3	<b>2.1</b>	7840	3.7	<b>3.2</b>	7380	7.4	<b>5.8</b>	6680	14900	
	<b>447.55</b>	1.7	<b>1.4</b>	7230	2.0	<b>1.7</b>	7030	3.2	<b>2.5</b>	6540	6.5	<b>4.5</b>	5950	12800	
	<b>491.52</b>	1.5	<b>1.4</b>	7810	1.8	<b>1.7</b>	7730	3.0	<b>2.6</b>	7520	5.9	<b>4.8</b>	6870	14900	
	<b>558.55</b>	1.3	<b>1.2</b>	7480	1.6	<b>1.4</b>	7270	2.6	<b>2.1</b>	6770	5.2	<b>3.7</b>	6090	12800	
	<b>629.37</b>	1.2	<b>0.84</b>	5960	1.4	<b>0.99</b>	5900	2.3	<b>1.6</b>	5740	4.6	<b>3.0</b>	5520	12800	

# RE 810



	ie	n <sub>1</sub> = 750 RPM			n <sub>1</sub> = 900 RPM			n <sub>1</sub> = 1450 RPM			n <sub>1</sub> = 2900 RPM			T <sub>2max</sub> [Nm]	P <sub>t</sub> [kW]
		n <sub>2</sub> [RPM]	P <sub>1</sub> [kW]	T <sub>2</sub> [Nm]	n <sub>2</sub> [RPM]	P <sub>1</sub> [kW]	T <sub>2</sub> [Nm]	n <sub>2</sub> [RPM]	P <sub>1</sub> [kW]	T <sub>2</sub> [Nm]	n <sub>2</sub> [RPM]	P <sub>1</sub> [kW]	T <sub>2</sub> [Nm]		
RE 811	3.56	211	155	6860	253	108	3970	407	150	3440	—	—	—	18600	30 (N) 29 (T) 19 (F) 56 (P)
	4.15	181	118	6100	217	95	4090	349	133	3550	—	—	—	16800	
	5.10	147	81	5130	176	81	4250	284	113	3690	—	—	—	14200	
	5.82	129	60	4370	155	72	4330	249	102	3800	—	—	—	12100	
	6.86	109	44.2	3760	131	52	3720	211	82	3620	—	—	—	10400	
RE 812	12.83	58	47.6	7380	70	45.1	5830	113	63	5060	226	102	4110	18600	17 (N) 16 (T) 11 (F) 31 (P)
	15.14	49.5	39.9	7310	59	40.1	6130	96	56	5310	192	91	4320	18600	
	17.65	42.5	31.0	6630	51	35.5	6320	82	49.5	5470	164	80.5	4450	16800	
	18.36	40.8	24.9	5520	49.0	29.5	5470	79	46.3	5320	158	76.5	4400	14200	
	22.15	33.9	25.0	6710	40.6	29.7	6640	65	42.2	5860	131	68.6	4760	16800	
	25.75	29.1	18.8	5870	34.9	22.4	5810	56	35.1	5660	113	61.8	4980	16200	
	27.20	27.6	17.2	5650	33.1	20.4	5590	53	31.9	5440	107	58.1	4950	14200	
	31.62	23.7	14.9	5700	28.5	17.7	5640	45.9	27.7	5490	92	52.3	5180	14200	
	36.11	20.8	11.1	4850	24.9	13.2	4800	40.2	20.7	4670	80	39.7	4490	12100	
	38.25	19.6	12.2	5660	23.5	14.5	5610	37.9	22.8	5460	76	43.8	5240	14200	
	43.68	17.2	9.3	4900	20.6	11.0	4850	33.2	17.3	4720	66	33.2	4540	12100	
51.43	14.6	6.8	4220	17.5	8.1	4180	28.2	12.6	4060	56	24.3	3910	10400		
RE 813	52.69	14.2	12.6	7850	17.1	15.0	7770	27.5	23.5	7560	55	39.0	6270	18600	12 (N) 12 (T) 8 (F) 22 (P)
	54.68	13.7	12.4	8020	16.5	14.8	7940	26.5	21.2	7060	53	34.4	5730	18600	
	63.75	11.8	9.5	7130	14.1	11.3	7060	22.7	17.6	6870	45.5	33.6	6540	16800	
	75.26	10.0	8.1	7200	12.0	9.6	7120	19.3	15.1	6930	38.5	29.0	6660	16800	
	77.10	9.7	7.9	7210	11.7	9.4	7130	18.8	14.8	6940	37.6	28.4	6670	16800	
	87.35	8.6	7.0	7230	10.3	8.3	7150	16.6	13.1	6960	33.2	25.1	6690	18600	
	101.85	7.4	6.2	7450	8.8	7.2	7250	14.2	11.3	7050	28.5	21.8	6780	16800	
	109.62	6.8	5.1	6600	8.2	6.1	6530	13.2	9.5	6360	26.5	18.3	6110	16500	
	127.81	5.9	5.1	7700	7.0	6.0	7500	11.3	9.2	7150	22.7	17.6	6870	16800	
	134.80	5.6	4.0	6310	6.7	4.6	6130	10.8	7.2	5960	21.5	13.9	5730	14200	
	156.92	4.8	3.5	6450	5.7	4.1	6280	9.2	6.3	6010	18.5	12.1	5780	14200	
	182.42	4.1	3.1	6600	4.9	3.6	6420	7.9	5.4	6060	15.9	10.5	5830	14200	
	195.84	3.8	2.9	6670	4.6	3.4	6490	7.4	5.1	6090	14.8	9.8	5850	14200	
	227.66	3.3	2.5	6830	4.0	3.0	6640	6.4	4.4	6180	12.7	8.5	5900	14200	
251.98	3.0	1.9	5770	3.6	2.3	5610	5.8	3.4	5220	11.5	6.5	5020	12100		
275.40	2.7	2.0	6340	3.3	2.3	6280	5.3	3.6	6110	10.5	7.0	5870	14200		
314.47	2.4	1.6	5960	2.9	1.9	5800	4.6	2.8	5400	9.2	5.3	5080	12100		
RE 814	183.36	4.1	4.0	8430	4.9	4.7	8340	7.9	7.4	8120	15.8	14.3	7800	18600	9 (N) 9 (T) 7 (F) 17 (P)
	224.62	3.3	3.3	8530	4.0	3.9	8440	6.5	6.1	8210	12.9	11.8	7900	18600	
	261.91	2.9	2.9	8590	3.4	3.3	8360	5.5	5.0	7780	11.1	9.2	7160	16800	
	275.17	2.7	2.7	8630	3.3	3.2	8540	5.3	5.1	8310	10.5	9.8	7990	18600	
	320.85	2.3	2.4	8860	2.8	2.8	8620	4.5	4.2	8020	9.0	7.6	7240	16800	
	354.43	2.1	2.2	9000	2.5	2.6	8750	4.1	3.9	8140	8.2	7.0	7330	16800	
	393.66	1.9	2.1	9300	2.3	2.4	9200	3.7	3.7	8770	7.4	7.2	8430	18600	
	459.00	1.6	1.8	9350	2.0	2.1	9100	3.2	3.1	8470	6.3	5.6	7620	16800	
	503.94	1.5	1.4	7990	1.8	1.6	7910	2.9	2.6	7690	5.8	4.9	7390	18600	
	541.88	1.4	1.5	9590	1.7	1.8	9330	2.7	2.7	8680	5.4	4.8	7820	16800	
	634.83	1.2	1.1	7970	1.4	1.3	7750	2.3	1.9	7210	4.6	3.4	6500	14200	
	733.31	1.0	1.1	9430	1.2	1.3	9330	2.0	2.1	9080	4.0	3.8	8180	16800	
	792.27	0.95	0.90	8240	1.1	1.1	8020	1.8	1.6	7460	3.7	2.8	6720	14200	
	905.33	0.83	0.81	8410	0.99	0.94	8180	1.6	1.4	7610	3.2	2.5	6850	14200	
	1052.44	0.71	0.71	8600	0.86	0.83	8370	1.4	1.2	7790	2.8	2.2	7010	14200	
	1129.85	0.66	0.67	8700	0.80	0.78	8460	1.3	1.2	7870	2.6	2.1	7090	14200	
	1313.45	0.57	0.59	8900	0.69	0.69	8660	1.1	1.0	8050	2.2	1.9	7250	14200	
	1410.05	0.53	0.55	8990	0.64	0.65	8750	1.0	0.97	8140	2.1	1.7	7330	14200	
	1639.18	0.46	0.49	9200	0.55	0.57	8950	0.88	0.85	8330	1.8	1.5	7500	14200	
1814.25	0.41	0.37	7780	0.50	0.43	7560	0.80	0.65	7040	1.6	1.2	6340	12100		
1982.88	0.38	0.34	7650	0.45	0.39	7440	0.73	0.59	6920	1.5	1.1	6570	14200		
2264.19	0.33	0.31	8040	0.40	0.36	7820	0.64	0.54	7280	1.3	0.97	6550	12100		

	ie	n <sub>1</sub> = 750 RPM			n <sub>1</sub> = 900 RPM			n <sub>1</sub> = 1450 RPM			n <sub>1</sub> = 2900 RPM			T <sub>2max</sub> [Nm]	P <sub>t</sub> [kW]
		n <sub>2</sub> [RPM]	P <sub>1</sub> [kW]	T <sub>2</sub> [Nm]	n <sub>2</sub> [RPM]	P <sub>1</sub> [kW]	T <sub>2</sub> [Nm]	n <sub>2</sub> [RPM]	P <sub>1</sub> [kW]	T <sub>2</sub> [Nm]	n <sub>2</sub> [RPM]	P <sub>1</sub> [kW]	T <sub>2</sub> [Nm]		
RA 812	10.41	72	46.6	5790	86	53	5480	139	74	4750	278	120	3860	18600	16 (N) 16 (T) 13 (F) 29 (P)
	12.14	62	41.2	5960	74	46.8	5650	119	65.4	4890	239	106	3970	16800	
	14.25	53	37.4	6360	63	42.5	6020	102	59.4	5220	204	96	4240	18600	
	16.62	45.1	33.1	6550	54	37.6	6200	87	52.5	5380	175	85	4370	16800	
	20.40	36.8	22.9	5560	44.1	27.1	5500	71	42.5	5350	142	72	4540	14200	
	23.29	32.2	17.0	4730	38.6	20.2	4680	62	31.7	4560	124	61	4380	12100	
	27.43	27.3	12.5	4070	32.8	14.8	4030	53	23.2	3920	106	44.6	3770	10400	
RA 813	35.73	21.0	18.9	7830	25.2	22.4	7750	40.6	32.0	6870	81	52	5580	18600	12 (N) 12 (T) 9 (F) 25 (P)
	41.66	18.0	14.4	6960	21.6	17.1	6890	34.8	26.8	6700	70	46.0	5750	16800	
	51.30	14.6	13.4	7990	17.5	15.9	7910	28.3	24.8	7660	57	40.4	6220	18600	
	60.56	12.4	11.2	7910	14.9	13.4	7830	23.9	20.9	7620	47.9	35.9	6540	18600	
	70.62	10.6	8.7	7170	12.7	10.4	7100	20.5	16.3	6910	41.1	31.3	6640	16800	
	76.00	9.9	7.3	6460	11.8	8.7	6400	19.1	13.6	6230	38.2	26.2	5980	16500	
	88.62	8.5	7.1	7290	10.2	8.4	7190	16.4	13.1	7000	32.7	25.3	6730	16800	
	103.02	7.3	5.3	6360	8.7	6.3	6290	14.1	9.9	6120	28.2	19.0	5890	16200	
	108.80	6.9	4.8	6110	8.3	5.7	6050	13.3	9.0	5890	26.7	17.3	5660	14200	
	126.48	5.9	4.2	6240	7.1	5.0	6100	11.5	7.8	5940	22.9	15.0	5710	14200	
	144.42	5.2	3.2	5300	6.2	3.7	5200	10.0	5.8	5060	20.1	11.2	4860	12100	
	153.00	4.9	3.4	6130	5.9	4.1	6070	9.5	6.4	5910	19.0	12.3	5680	14200	
	174.71	4.3	2.7	5460	5.2	3.1	5310	8.3	4.9	5110	16.6	9.4	4910	12100	
RA 814	142.82	5.3	5.3	8590	6.3	6.3	8500	10.2	9.8	8210	20.3	18.5	7760	18600	8 (N) 8 (T) 6 (F) 15 (P)
	168.61	4.4	4.4	8390	5.3	5.2	8300	8.6	8.2	8080	17.2	15.7	7770	18600	
	174.96	4.3	4.4	8690	5.1	5.2	8600	8.3	8.2	8370	16.6	15.5	7940	18600	
	206.55	3.6	3.6	8490	4.4	4.3	8400	7.0	6.8	8180	14.0	13.0	7860	18600	
	211.58	3.5	2.9	6850	4.3	3.4	6780	6.9	5.3	6600	13.7	10.2	6340	16500	
	246.71	3.0	2.9	7990	3.6	3.4	7910	5.9	5.3	7700	11.8	9.9	7130	16800	
	279.52	2.7	2.4	7720	3.2	2.9	7640	5.2	4.5	7440	10.4	8.7	7150	18600	
	302.23	2.5	2.4	8090	3.0	2.8	8000	4.8	4.4	7790	9.6	8.1	7210	16800	
	352.12	2.1	1.8	7290	2.6	2.1	7090	4.1	3.2	6600	8.2	5.9	6050	14200	
	408.99	1.8	1.8	8230	2.2	2.1	8140	3.5	3.3	7920	7.1	6.3	7490	16800	
	431.36	1.7	1.5	7520	2.1	1.8	7310	3.4	2.7	6800	6.7	4.8	6130	14200	
	502.15	1.5	1.4	7690	1.8	1.6	7480	2.9	2.4	6960	5.8	4.3	6270	14200	
	583.75	1.3	1.2	7870	1.5	1.4	7660	2.5	2.1	7120	5.0	3.7	6410	14200	
	626.69	1.2	1.1	7960	1.4	1.3	7740	2.3	2.0	7200	4.6	3.5	6480	14200	
	728.52	1.0	0.99	8140	1.2	1.2	7920	2.0	1.7	7370	4.0	3.1	6630	14200	
	806.33	0.93	0.75	6880	1.1	0.88	6690	1.8	1.3	6230	3.6	2.4	5610	12100	
	881.28	0.85	0.68	6780	1.0	0.81	6710	1.6	1.3	6530	3.3	2.4	6270	14200	
	1006.31	0.75	0.62	7110	0.89	0.73	6920	1.4	1.1	6440	2.9	2.0	5800	12100	
1184.91	0.63	0.45	6100	0.76	0.53	5940	1.2	0.80	5520	2.4	1.4	4970	10400		

# RE 1020



	ie	n <sub>1</sub> = 750 RPM			n <sub>1</sub> = 900 RPM			n <sub>1</sub> = 1450 RPM			n <sub>1</sub> = 2900 RPM			T <sub>2max</sub> [Nm]	P <sub>t</sub> [kW]
		n <sub>2</sub> [RPM]	P <sub>1</sub> [kW]	T <sub>2</sub> [Nm]	n <sub>2</sub> [RPM]	P <sub>1</sub> [kW]	T <sub>2</sub> [Nm]	n <sub>2</sub> [RPM]	P <sub>1</sub> [kW]	T <sub>2</sub> [Nm]	n <sub>2</sub> [RPM]	P <sub>1</sub> [kW]	T <sub>2</sub> [Nm]		
RE 1021	3.56	211	130	5750	253	148	5440	407	206	4720	—	—	—	27200	36 (T) 22 (F) 58 (P)
	4.15	181	115	5920	217	131	5610	349	182	4860	—	—	—	24200	
	5.10	147	97	6160	176	111	5830	284	154	5050	—	—	—	20400	
	5.82	129	87	6320	155	100	6010	249	139	5200	—	—	—	17400	
	6.86	109	64	5440	131	76	5380	211	119	5240	—	—	—	15000	
RE 1022	12.83	58	54	8440	70	62	8000	113	86	6930	226	140	5630	27200	20 (T) 13 (F) 33 (P)
	15.14	49.5	48.4	8880	59	55	8400	96	77	7280	192	125	5920	27200	
	17.65	42.5	42.8	9140	51	48.6	8660	82	68	7500	164	110	6090	24200	
	19.00	39.5	41.3	9500	47.4	46.9	9000	76	66	7800	153	106	6330	27200	
	22.15	33.9	36.3	9720	40.6	41.5	9270	65	58	8030	131	94	6520	24200	
	25.75	29.1	31.5	9810	34.9	37.3	9700	56	52	8400	113	85	6830	24200	
	27.20	27.6	24.8	8170	33.1	29.5	8080	53	46.2	7870	107	79.7	6780	20400	
	31.62	23.7	21.5	8240	28.5	25.6	8150	45.9	40.1	7930	92	71.7	7100	20400	
	36.11	20.8	16.1	7020	24.9	19.1	6940	40.2	29.9	6760	80	57.5	6490	17400	
	38.25	19.6	18.0	8330	23.5	21.4	8240	37.9	33.5	8020	76	62.7	7510	20400	
	43.68	17.2	13.4	7090	20.6	15.9	7020	33.2	25.0	6830	66	48.0	6570	17400	
51.43	14.6	9.8	6110	17.5	11.6	6040	28.2	18.3	5880	56	35.1	5650	15000		
RE 1023	52.69	14.2	18.6	11600	17.1	22.1	11500	27.5	32.9	10600	55	53.5	8600	27200	15 (T) 10 (F) 22 (P)
	54.68	13.7	18.0	11600	16.5	21.4	11500	26.5	32.1	10700	53	52.1	8700	27200	
	63.75	11.8	13.7	10300	14.1	16.3	10200	22.7	25.6	9950	45.5	46.0	8960	24200	
	73.99	10.1	13.6	11900	12.2	16.1	11700	19.6	25.2	11400	39.2	42.2	9500	27200	
	81.00	9.3	12.6	12100	11.1	14.8	11800	17.9	23.1	11400	35.8	39.6	9800	27200	
	87.35	8.6	11.8	12200	10.3	13.8	11900	16.6	21.5	11500	33.2	37.5	10000	27200	
	89.62	8.4	10.0	10600	10.0	11.8	10400	16.2	18.5	10100	32.4	35.6	9750	24200	
	101.85	7.4	9.0	10800	8.8	10.5	10500	14.2	16.4	10200	28.5	31.6	9820	24200	
	109.62	6.8	9.8	12600	8.2	11.4	12300	13.2	17.4	11600	26.5	32.0	10700	27200	
	127.81	5.9	7.4	11200	7.0	8.6	10900	11.3	13.3	10300	22.7	25.5	9950	24200	
	148.58	5.0	6.5	11400	6.1	7.6	11100	9.8	11.5	10400	19.5	22.1	10000	24200	
	159.51	4.7	6.1	11500	5.6	7.2	11200	9.1	10.8	10500	18.2	20.7	10100	24200	
	185.43	4.0	5.4	11800	4.9	6.3	11500	7.8	9.4	10700	15.6	18.0	10200	24200	
	195.84	3.8	4.2	9650	4.6	4.9	9390	7.4	7.4	8810	14.8	14.2	8460	20400	
	227.66	3.3	3.7	9870	4.0	4.3	9600	6.4	6.4	8930	12.7	12.3	8540	20400	
	275.40	2.7	3.1	10160	3.3	3.6	9880	5.3	5.5	9190	10.5	10.3	8630	20400	
314.47	2.4	2.3	8630	2.9	2.7	8390	4.6	4.1	7810	9.2	7.7	7350	17400		
RE 1024	190.27	3.9	6.3	13700	4.7	7.3	13300	7.6	11.0	12400	15.2	20.4	11500	27200	12 (T) 8 (F) 17 (P)
	224.62	3.3	5.4	14100	4.0	6.4	13700	6.5	9.5	12700	12.9	17.4	11700	27200	
	257.49	2.9	4.8	14400	3.5	5.7	14000	5.6	8.5	13000	11.3	15.3	11700	27200	
	275.17	2.7	4.6	14500	3.3	5.3	14100	5.3	8.0	13100	10.5	14.4	11800	27200	
	315.43	2.4	4.1	14800	2.9	4.8	14400	4.6	7.1	13400	9.2	12.9	12100	27200	
	345.32	2.2	3.7	14500	2.6	4.3	14400	4.2	6.6	13600	8.4	11.9	12200	27200	
	393.66	1.9	3.4	15300	2.3	3.9	14900	3.7	5.9	13900	7.4	10.7	12500	27200	
	503.94	1.5	2.7	15900	1.8	3.2	15500	2.9	4.8	14400	5.8	8.6	13000	27200	
	583.20	1.3	2.3	15400	1.5	2.7	15000	2.5	4.2	14400	5.0	7.6	13200	27200	
	632.40	1.2	2.1	15600	1.4	2.5	15200	2.3	3.8	14500	4.6	7.1	13400	27200	
	733.31	1.0	1.7	14500	1.2	2.0	14100	2.0	3.0	13200	4.0	5.4	11900	24200	
	857.19	0.87	1.5	14900	1.0	1.8	14500	1.7	2.6	13500	3.4	4.8	12100	24200	
	920.24	0.82	1.4	15100	0.98	1.7	14600	1.6	2.5	13600	3.2	4.5	12300	24200	
	984.96	0.76	1.3	14700	0.91	1.5	14600	1.5	2.4	14200	2.9	4.7	13700	27200	
	1148.46	0.65	1.2	15600	0.78	1.4	15100	1.3	2.1	14100	2.5	3.7	12700	24200	
	1273.11	0.59	0.87	12800	0.71	1.0	12500	1.1	1.5	11600	2.3	2.8	10400	20400	
	1410.05	0.53	0.80	13000	0.64	0.94	12700	1.0	1.4	11800	2.1	2.5	10600	20400	
	1588.85	0.47	0.72	13200	0.57	0.85	12900	0.91	1.3	12000	1.8	2.3	10800	20400	
	1814.25	0.41	0.54	11200	0.50	0.63	10900	0.80	0.94	10200	1.6	1.70	9170	17400	
1982.88	0.38	0.60	13700	0.45	0.70	13300	0.73	1.05	12400	1.5	1.89	11200	20400		
2264.19	0.33	0.45	11600	0.40	0.52	11300	0.64	0.78	10500	1.3	1.41	9480	17400		

	ie	n <sub>1</sub> = 750 RPM			n <sub>1</sub> = 900 RPM			n <sub>1</sub> = 1450 RPM			n <sub>1</sub> = 2900 RPM			T <sub>2max</sub> [Nm]	P <sub>t</sub> [kW]
		n <sub>2</sub> [RPM]	P <sub>1</sub> [kW]	T <sub>2</sub> [Nm]	n <sub>2</sub> [RPM]	P <sub>1</sub> [kW]	T <sub>2</sub> [Nm]	n <sub>2</sub> [RPM]	P <sub>1</sub> [kW]	T <sub>2</sub> [Nm]	n <sub>2</sub> [RPM]	P <sub>1</sub> [kW]	T <sub>2</sub> [Nm]		
<b>RA 1022</b>	10.41	72	<b>64</b>	7930	86	<b>73</b>	7510	139	<b>101</b>	6510	278	<b>165</b>	5290	27200	19 (T) 14 (F) 29 (P)
	12.14	61	<b>56</b>	8170	74	<b>64</b>	7740	119	<b>90</b>	6707	239	<b>146</b>	5450	24200	
	14.25	53	<b>51.3</b>	8720	63	<b>58</b>	8250	102	<b>81</b>	7152	204	<b>132</b>	5810	24700	
	16.62	45	<b>45.3</b>	8980	54	<b>52</b>	8500	87	<b>72</b>	7369	175	<b>117</b>	5990	24200	
	20.40	36.8	<b>33.0</b>	8030	44.1	<b>39.2</b>	7950	71	<b>61</b>	7660	142	<b>99</b>	6220	20400	
	23.29	32.2	<b>24.6</b>	6840	38.6	<b>29.3</b>	6770	62	<b>45.9</b>	6590	124	<b>88</b>	6330	17400	
	27.43	27.3	<b>18.0</b>	5890	32.8	<b>21.4</b>	5830	53	<b>33.5</b>	5672	106	<b>64</b>	5450	15000	
<b>RA 1023</b>	35.73	21.0	<b>27.3</b>	11300	25.2	<b>31.4</b>	10900	40.6	<b>43.9</b>	9423	81	<b>71</b>	7650	27200	14 (T) 10 (F) 25 (P)
	41.66	18.0	<b>20.8</b>	10100	21.6	<b>24.7</b>	9980	34.8	<b>38.8</b>	9707	70	<b>63</b>	7890	24200	
	49.18	15.3	<b>17.8</b>	10200	18.3	<b>21.1</b>	10100	29.5	<b>33.2</b>	9800	59	<b>56</b>	8290	24200	
	59.82	12.5	<b>14.8</b>	10300	15.0	<b>17.6</b>	10200	24.2	<b>27.6</b>	9910	48.5	<b>48.9</b>	8790	24200	
	61.71	12.2	<b>14.4</b>	10300	14.6	<b>17.1</b>	10200	23.5	<b>26.8</b>	9927	47.0	<b>47.8</b>	8870	24200	
	70.62	10.6	<b>12.7</b>	10400	12.7	<b>15.0</b>	10300	20.5	<b>23.6</b>	10004	41.1	<b>43.5</b>	9240	24200	
	76.00	9.9	<b>13.5</b>	11900	11.8	<b>15.9</b>	11700	19.1	<b>24.9</b>	11396	38.2	<b>42.0</b>	9600	27200	
	88.62	8.5	<b>8.5</b>	8740	10.2	<b>12.1</b>	10400	16.4	<b>19.0</b>	10135	32.7	<b>36.6</b>	9740	24200	
	103.02	7.3	<b>9.0</b>	10800	8.7	<b>10.5</b>	10500	14.1	<b>16.5</b>	10222	28.2	<b>31.7</b>	9830	24200	
	108.80	6.9	<b>7.0</b>	8840	8.3	<b>8.3</b>	8750	13.3	<b>13.0</b>	8514	26.7	<b>25.0</b>	8180	20400	
	126.48	5.9	<b>6.1</b>	9030	7.1	<b>7.2</b>	8830	11.5	<b>11.3</b>	8588	22.9	<b>21.7</b>	8250	20400	
	153.00	4.9	<b>5.2</b>	9290	5.9	<b>6.1</b>	9040	9.5	<b>9.4</b>	8682	19.0	<b>18.1</b>	8340	20400	
	174.71	4.3	<b>3.9</b>	7890	5.2	<b>4.5</b>	7680	8.3	<b>7.0</b>	7394	16.6	<b>13.5</b>	7110	17400	
<b>RA 1024</b>	142.82	5.3	<b>7.5</b>	12100	6.3	<b>8.9</b>	11900	10.2	<b>13.1</b>	10941	20.3	<b>21.2</b>	8890	27200	10 (T) 7 (F) 15 (P)
	168.61	4.5	<b>7.1</b>	13500	5.3	<b>8.2</b>	13100	8.6	<b>12.3</b>	12190	17.2	<b>21.2</b>	10500	27200	
	174.96	4.3	<b>6.8</b>	13500	5.1	<b>8.0</b>	13200	8.3	<b>12.0</b>	12258	16.6	<b>21.2</b>	10900	27200	
	206.55	3.6	<b>5.9</b>	13900	4.4	<b>6.9</b>	13500	7.0	<b>10.4</b>	12570	14.0	<b>19.2</b>	11600	27200	
	236.77	3.2	<b>4.9</b>	13200	3.8	<b>5.8</b>	13100	6.1	<b>9.2</b>	12711	12.2	<b>16.8</b>	11700	27200	
	259.20	2.9	<b>4.9</b>	14300	3.5	<b>5.7</b>	14000	5.6	<b>8.6</b>	13009	11.2	<b>15.5</b>	11700	27200	
	302.23	2.5	<b>3.7</b>	12700	3.0	<b>4.3</b>	12400	4.8	<b>6.5</b>	11511	9.6	<b>11.8</b>	10400	24200	
	350.77	2.1	<b>3.7</b>	14500	2.6	<b>4.3</b>	14400	4.1	<b>6.6</b>	13618	8.3	<b>11.9</b>	12300	27200	
	408.99	1.8	<b>2.9</b>	13300	2.2	<b>3.4</b>	13000	3.5	<b>5.0</b>	12050	7.1	<b>9.1</b>	10900	24200	
	475.46	1.6	<b>2.5</b>	13600	1.9	<b>3.0</b>	13200	3.0	<b>4.4</b>	12327	6.1	<b>8.0</b>	11100	24200	
	510.42	1.5	<b>2.4</b>	13800	1.8	<b>2.8</b>	13400	2.8	<b>4.2</b>	12460	5.7	<b>7.5</b>	11200	24200	
	593.37	1.3	<b>2.1</b>	14100	1.5	<b>2.4</b>	13700	2.4	<b>3.7</b>	12748	4.9	<b>6.6</b>	11500	24200	
	706.15	1.1	<b>1.5</b>	11700	1.3	<b>1.7</b>	11400	2.1	<b>2.6</b>	10602	4.1	<b>4.6</b>	9550	20400	
	806.33	0.93	<b>1.1</b>	9950	1.1	<b>1.3</b>	9680	1.8	<b>1.9</b>	9004	3.6	<b>3.4</b>	8110	17400	
	881.28	0.85	<b>1.2</b>	12100	1.0	<b>1.4</b>	11800	1.6	<b>2.1</b>	10963	3.3	<b>3.8</b>	9870	20400	
	1006.31	0.75	<b>0.90</b>	10300	0.89	<b>1.1</b>	10000	1.4	<b>1.6</b>	9311	2.9	<b>2.8</b>	8380	17400	
	1184.91	0.63	<b>0.66</b>	8830	0.76	<b>0.77</b>	8590	1.2	<b>1.15</b>	7991	2.4	<b>2.1</b>	7200	15000	

	ie	n <sub>1</sub> = 750 RPM			n <sub>1</sub> = 900 RPM			n <sub>1</sub> = 1450 RPM			n <sub>1</sub> = 2900 RPM			T <sub>2max</sub> [Nm]	P <sub>t</sub> [kW]
		n <sub>2</sub> [RPM]	P <sub>1</sub> [kW]	T <sub>2</sub> [Nm]	n <sub>2</sub> [RPM]	P <sub>1</sub> [kW]	T <sub>2</sub> [Nm]	n <sub>2</sub> [RPM]	P <sub>1</sub> [kW]	T <sub>2</sub> [Nm]	n <sub>2</sub> [RPM]	P <sub>1</sub> [kW]	T <sub>2</sub> [Nm]		
<b>RE 1521</b>	<b>4.09</b>	183	<b>193</b>	9800	220	<b>219</b>	9280	354	<b>306</b>	8040	—	—	—	39000	44 (T) 36 (H) 28 (F)
	<b>5.25</b>	143	<b>158</b>	10300	171	<b>179</b>	9730	276	<b>250</b>	8430	—	—	—	30500	
	<b>6.23</b>	120	<b>114</b>	8780	144	<b>135</b>	8690	233	<b>211</b>	8460	—	—	—	24200	
<b>RE 1522</b>	<b>14.73</b>	51	<b>78</b>	13900	61	<b>89</b>	13200	98	<b>124</b>	11400	197	<b>201</b>	9270	39000	25 (T) 21 (H) 16 (F)
	<b>17.39</b>	43.1	<b>68</b>	14400	52	<b>78</b>	13600	83	<b>108</b>	11800	167	<b>176</b>	9590	39000	
	<b>21.82</b>	34.4	<b>53</b>	14100	41.3	<b>64</b>	14000	66	<b>90</b>	12300	133	<b>146</b>	9990	38900	
	<b>25.36</b>	29.6	<b>38.9</b>	11900	35.5	<b>46.2</b>	11800	57	<b>72</b>	11500	114	<b>130</b>	10400	32900	
	<b>28.00</b>	26.8	<b>35.9</b>	12200	32.1	<b>42.7</b>	12100	52	<b>67</b>	11700	104	<b>129</b>	11300	30500	
	<b>32.55</b>	23.0	<b>31.2</b>	12300	27.6	<b>37.0</b>	12200	44.5	<b>58</b>	11800	89	<b>112</b>	11400	30500	
	<b>33.23</b>	22.6	<b>24.0</b>	9700	27.1	<b>28.5</b>	9570	43.6	<b>44.7</b>	9310	87	<b>86</b>	8950	24200	
	<b>39.38</b>	19.0	<b>25.2</b>	12000	22.9	<b>29.9</b>	11900	36.8	<b>46.9</b>	11600	74	<b>90</b>	11100	30500	
	<b>46.73</b>	16.0	<b>17.4</b>	9900	19.3	<b>20.7</b>	9750	31.0	<b>32.4</b>	9490	62	<b>62</b>	9120	24200	
<b>RE 1523</b>	<b>51.25</b>	14.6	<b>27.2</b>	16400	17.6	<b>31.7</b>	16000	28.3	<b>44.2</b>	13800	57	<b>72</b>	11200	39000	17 (T) 15 (H) 12 (F)
	<b>60.50</b>	12.4	<b>23.2</b>	16600	14.9	<b>27.6</b>	16400	24.0	<b>43.2</b>	16000	47.9	<b>72</b>	13300	39000	
	<b>62.78</b>	11.9	<b>22.4</b>	16600	14.3	<b>26.6</b>	16400	23.1	<b>37.8</b>	14500	46.2	<b>61</b>	11800	39000	
	<b>74.12</b>	10.1	<b>19.2</b>	16800	12.1	<b>22.8</b>	16600	19.6	<b>35.7</b>	16200	39.1	<b>61</b>	13900	39000	
	<b>80.57</b>	9.3	<b>13.6</b>	12900	11.2	<b>16.2</b>	12800	18.0	<b>25.3</b>	12500	36.0	<b>49</b>	12000	30500	
	<b>93.01</b>	8.1	<b>14.0</b>	15300	9.7	<b>16.6</b>	15200	15.6	<b>26.0</b>	14800	31.2	<b>50</b>	14200	38900	
	<b>100.31</b>	7.5	<b>14.1</b>	16700	9.0	<b>16.8</b>	16600	14.5	<b>26.3</b>	16100	28.9	<b>48.1</b>	14700	39000	
	<b>109.04</b>	6.9	<b>10.2</b>	13200	8.3	<b>12.1</b>	13000	13.3	<b>19.0</b>	12700	26.6	<b>36.6</b>	12200	30500	
	<b>125.87</b>	6.0	<b>10.5</b>	15600	7.2	<b>12.5</b>	15500	11.5	<b>19.6</b>	15000	23.0	<b>37.6</b>	14500	38900	
	<b>146.33</b>	5.1	<b>7.6</b>	13200	6.2	<b>9.1</b>	13100	9.9	<b>14.2</b>	12700	19.8	<b>27.4</b>	12200	32900	
	<b>157.09</b>	4.8	<b>8.2</b>	15100	5.7	<b>9.7</b>	15000	9.2	<b>15.2</b>	14600	18.5	<b>29.2</b>	14000	38900	
	<b>182.62</b>	4.1	<b>6.2</b>	13400	4.9	<b>7.4</b>	13200	7.9	<b>11.6</b>	12900	15.9	<b>22.2</b>	12400	32900	
	<b>201.60</b>	3.7	<b>6.0</b>	14400	4.5	<b>7.1</b>	14000	7.2	<b>10.7</b>	13100	14.4	<b>20.5</b>	12600	30500	
	<b>234.36</b>	3.2	<b>5.3</b>	14700	3.8	<b>6.2</b>	14300	6.2	<b>9.3</b>	13300	12.4	<b>17.8</b>	12700	30500	
	<b>239.26</b>	3.1	<b>4.0</b>	11400	3.8	<b>4.7</b>	11100	6.1	<b>7.1</b>	10400	12.1	<b>13.7</b>	10000	24200	
<b>278.14</b>	2.7	<b>3.5</b>	11600	3.2	<b>4.1</b>	11300	5.2	<b>6.2</b>	10500	10.4	<b>11.9</b>	10100	24200		
<b>RE 1524</b>	<b>210.56</b>	3.6	<b>8.0</b>	19400	4.3	<b>9.4</b>	18900	6.9	<b>14.0</b>	17600	13.8	<b>26.3</b>	16500	39000	14 (T) 12 (F) 9 (P)
	<b>218.49</b>	3.4	<b>7.8</b>	19500	4.1	<b>9.1</b>	19000	6.6	<b>13.6</b>	17700	13.3	<b>25.4</b>	16500	39000	
	<b>257.94</b>	2.9	<b>6.7</b>	20000	3.5	<b>7.9</b>	19500	5.6	<b>11.8</b>	18100	11.2	<b>21.7</b>	16700	39000	
	<b>280.40</b>	2.7	<b>4.7</b>	15100	3.2	<b>5.5</b>	14700	5.2	<b>8.2</b>	13700	10.3	<b>15.4</b>	12900	30500	
	<b>315.99</b>	2.4	<b>5.6</b>	20400	2.8	<b>6.6</b>	20100	4.6	<b>9.9</b>	18700	9.2	<b>17.9</b>	16900	39000	
	<b>349.06</b>	2.1	<b>5.1</b>	20500	2.6	<b>6.1</b>	20300	4.2	<b>9.1</b>	19000	8.3	<b>16.5</b>	17100	39000	
	<b>396.53</b>	1.9	<b>3.7</b>	16700	2.3	<b>4.3</b>	16500	3.7	<b>6.8</b>	16100	7.3	<b>13.1</b>	15400	38900	
	<b>452.05</b>	1.7	<b>4.1</b>	21400	2.0	<b>4.9</b>	21100	3.2	<b>7.3</b>	19700	6.4	<b>13.2</b>	17800	39000	
	<b>508.89</b>	1.5	<b>2.8</b>	16500	1.8	<b>3.3</b>	16100	2.8	<b>4.9</b>	15000	5.7	<b>8.9</b>	13500	30500	
	<b>578.69</b>	1.3	<b>2.8</b>	18500	1.6	<b>3.3</b>	18300	2.5	<b>5.2</b>	17800	5.0	<b>9.9</b>	17100	39000	
	<b>629.07</b>	1.2	<b>2.4</b>	17100	1.4	<b>2.8</b>	16600	2.3	<b>4.1</b>	15500	4.6	<b>7.4</b>	13900	30500	
	<b>722.20</b>	1.0	<b>2.3</b>	18700	1.2	<b>2.7</b>	18500	2.0	<b>4.2</b>	18000	4.0	<b>8.1</b>	17300	39000	
	<b>800.57</b>	0.94	<b>1.9</b>	17700	1.1	<b>2.2</b>	17200	1.8	<b>3.4</b>	16000	3.6	<b>6.1</b>	14400	30500	
	<b>906.29</b>	0.83	<b>1.8</b>	18600	0.99	<b>2.1</b>	18100	1.6	<b>3.1</b>	16800	3.2	<b>6.0</b>	16200	38900	
	<b>999.11</b>	0.75	<b>1.6</b>	18300	0.90	<b>1.9</b>	17800	1.5	<b>2.8</b>	16600	2.9	<b>5.0</b>	14900	30500	
	<b>1156.68</b>	0.65	<b>1.3</b>	17300	0.78	<b>1.5</b>	17100	1.3	<b>2.4</b>	16700	2.5	<b>4.4</b>	15300	30500	
	<b>1285.79</b>	0.58	<b>0.99</b>	14700	0.70	<b>1.2</b>	14300	1.1	<b>1.7</b>	13300	2.3	<b>3.1</b>	12000	24200	
	<b>1451.52</b>	0.52	<b>1.2</b>	19400	0.62	<b>1.4</b>	18900	1.0	<b>2.0</b>	17500	2.0	<b>3.7</b>	15800	30500	
<b>1635.58</b>	0.46	<b>0.83</b>	15700	0.55	<b>0.97</b>	15300	0.89	<b>1.5</b>	14300	1.8	<b>2.8</b>	13800	30500		
<b>1722.68</b>	0.44	<b>0.77</b>	15300	0.52	<b>0.90</b>	14900	0.84	<b>1.4</b>	13900	1.7	<b>2.4</b>	12500	24200		
<b>2041.20</b>	0.37	<b>0.69</b>	16200	0.44	<b>0.81</b>	15800	0.71	<b>1.2</b>	14700	1.4	<b>2.3</b>	13900	30500		

	ie	n <sub>1</sub> = 750 RPM			n <sub>1</sub> = 900 RPM			n <sub>1</sub> = 1450 RPM			n <sub>1</sub> = 2900 RPM			T <sub>2max</sub> [Nm]	P <sub>t</sub> [kW]
		n <sub>2</sub> [RPM]	P <sub>1</sub> [kW]	T <sub>2</sub> [Nm]	n <sub>2</sub> [RPM]	P <sub>1</sub> [kW]	T <sub>2</sub> [Nm]	n <sub>2</sub> [RPM]	P <sub>1</sub> [kW]	T <sub>2</sub> [Nm]	n <sub>2</sub> [RPM]	P <sub>1</sub> [kW]	T <sub>2</sub> [Nm]		
<b>RA 1522</b>	<b>12.56</b>	60	<b>91.7</b>	13700	72	<b>104</b>	13000	115	<b>145</b>	11300	231	<b>236</b>	9150	39000	24 (T) 20 (H) 18 (F)
	<b>16.13</b>	46.5	<b>61.4</b>	11800	56	<b>73</b>	11700	90	<b>114</b>	11400	180	<b>193</b>	9590	30500	
	<b>19.09</b>	39.3	<b>53.9</b>	12300	47.1	<b>64</b>	12100	76	<b>100</b>	11800	152	<b>176</b>	10400	31600	
	<b>24.50</b>	30.6	<b>41.4</b>	12100	36.7	<b>49.2</b>	12000	59	<b>77</b>	11600	118	<b>144</b>	10900	30500	
	<b>29.08</b>	25.8	<b>27.7</b>	9600	31.0	<b>32.9</b>	9500	49.9	<b>52</b>	9200	100	<b>99</b>	8880	24200	
<b>RA 1523</b>	<b>34.38</b>	21.8	<b>27.8</b>	11100	26.2	<b>31.6</b>	10500	42.2	<b>44.1</b>	9100	84	<b>72</b>	7400	34100	15 (T) 13 (H) 11 (F)
	<b>41.03</b>	18.3	<b>27.8</b>	13200	21.9	<b>31.6</b>	12500	35.3	<b>44.1</b>	10900	71	<b>72</b>	8830	39000	
	<b>48.43</b>	15.5	<b>27.8</b>	15600	18.6	<b>31.6</b>	14800	29.9	<b>44.1</b>	12800	60	<b>72</b>	10400	39000	
	<b>58.91</b>	12.7	<b>20.6</b>	14100	15.3	<b>23.4</b>	13300	24.9	<b>32.6</b>	11400	49.2	<b>53.0</b>	9380	39000	
	<b>62.16</b>	12.1	<b>17.6</b>	12700	14.5	<b>21.0</b>	12600	23.3	<b>32.9</b>	12300	46.7	<b>63</b>	11800	30500	
	<b>70.66</b>	10.6	<b>15.4</b>	12700	12.7	<b>18.3</b>	12500	20.5	<b>28.7</b>	12200	41.0	<b>55</b>	11700	24200	
	<b>78.00</b>	9.6	<b>14.2</b>	12900	11.5	<b>16.9</b>	12800	18.6	<b>26.5</b>	12400	37.2	<b>51</b>	12000	32900	
	<b>89.25</b>	8.4	<b>12.5</b>	13000	10.1	<b>14.9</b>	12900	16.2	<b>23.4</b>	12500	32.5	<b>44.9</b>	12000	30500	
	<b>101.45</b>	7.4	<b>11.0</b>	12900	8.9	<b>13.0</b>	12800	14.3	<b>20.4</b>	12500	28.6	<b>39.3</b>	12000	30500	
	<b>112.00</b>	6.7	<b>10.1</b>	13200	8.0	<b>12.0</b>	13000	12.9	<b>18.9</b>	12700	25.9	<b>36.2</b>	12200	32900	
	<b>130.20</b>	5.8	<b>8.9</b>	13500	6.9	<b>10.4</b>	13200	11.1	<b>16.4</b>	12800	22.3	<b>31.5</b>	12300	30500	
	<b>154.52</b>	4.9	<b>5.9</b>	10600	5.8	<b>7.0</b>	10400	9.4	<b>10.9</b>	10200	18.8	<b>21.0</b>	9770	30500	
	<b>186.92</b>	4.0	<b>5.0</b>	11000	4.8	<b>5.9</b>	10700	7.8	<b>9.1</b>	10300	15.5	<b>17.6</b>	9880	24200	
<b>RA 1524</b>	<b>164.00</b>	4.6	<b>7.5</b>	13900	5.5	<b>8.9</b>	13700	8.8	<b>13.1</b>	12600	17.7	<b>21.2</b>	10200	24200	11 (T) 9 (H) 8 (F)
	<b>193.61</b>	3.9	<b>7.5</b>	16400	4.6	<b>8.9</b>	16200	7.5	<b>13.1</b>	14800	15.0	<b>21.2</b>	12000	35500	
	<b>200.91</b>	3.7	<b>7.5</b>	17000	4.5	<b>8.9</b>	16800	7.2	<b>13.1</b>	15400	14.4	<b>21.2</b>	12500	39000	
	<b>237.19</b>	3.2	<b>7.4</b>	19800	3.8	<b>8.6</b>	19200	6.1	<b>12.9</b>	17900	12.2	<b>21.2</b>	14800	39000	
	<b>248.47</b>	3.0	<b>5.3</b>	14800	3.6	<b>6.2</b>	14400	5.8	<b>9.2</b>	13400	11.7	<b>17.5</b>	12800	39000	
	<b>271.89</b>	2.8	<b>4.9</b>	15200	3.3	<b>5.8</b>	15000	5.3	<b>9.2</b>	14600	10.7	<b>17.6</b>	14000	30500	
	<b>297.65</b>	2.5	<b>4.9</b>	16400	3.0	<b>5.8</b>	16200	4.9	<b>9.1</b>	15800	9.7	<b>17.4</b>	15200	39000	
	<b>320.98</b>	2.3	<b>4.9</b>	17900	2.8	<b>5.8</b>	17700	4.5	<b>9.2</b>	17200	9.0	<b>17.6</b>	16600	38900	
	<b>348.92</b>	2.1	<b>4.0</b>	15600	2.6	<b>4.6</b>	15200	4.2	<b>6.9</b>	14100	8.3	<b>12.7</b>	13000	39000	
	<b>402.80</b>	1.9	<b>3.7</b>	16700	2.2	<b>4.3</b>	16500	3.6	<b>6.8</b>	16100	7.2	<b>13.1</b>	15400	30500	
	<b>444.05</b>	1.7	<b>3.2</b>	16200	2.0	<b>3.8</b>	15800	3.3	<b>5.6</b>	14700	6.5	<b>10.1</b>	13200	38900	
	<b>516.92</b>	1.5	<b>2.8</b>	16600	1.7	<b>3.3</b>	16100	2.8	<b>5.0</b>	15000	5.6	<b>8.9</b>	13500	30500	
	<b>600.92</b>	1.2	<b>2.5</b>	17000	1.5	<b>2.9</b>	16500	2.4	<b>4.4</b>	15300	4.8	<b>7.8</b>	13800	30500	
	<b>645.12</b>	1.2	<b>2.3</b>	17100	1.4	<b>2.7</b>	16700	2.2	<b>4.1</b>	15500	4.5	<b>7.4</b>	14000	30500	
	<b>749.95</b>	1.0	<b>2.1</b>	17500	1.2	<b>2.4</b>	17100	1.9	<b>3.6</b>	15900	3.9	<b>6.5</b>	14300	30500	
	<b>907.20</b>	0.83	<b>1.4</b>	14400	0.99	<b>1.7</b>	14200	1.6	<b>2.6</b>	13800	3.2	<b>5.0</b>	13300	30500	
	<b>1076.68</b>	0.70	<b>1.2</b>	14300	0.84	<b>1.4</b>	13900	1.3	<b>2.0</b>	12900	2.7	<b>3.7</b>	11600	30500	

		n <sub>1</sub> = 750 RPM			n <sub>1</sub> = 900 RPM			n <sub>1</sub> = 1450 RPM			n <sub>1</sub> = 2900 RPM			T <sub>2max</sub> [Nm]	P <sub>t</sub> [kW]	
		ie	n <sub>2</sub> [RPM]	P <sub>1</sub> [kW]	T <sub>2</sub> [Nm]	n <sub>2</sub> [RPM]	P <sub>1</sub> [kW]	T <sub>2</sub> [Nm]	n <sub>2</sub> [RPM]	P <sub>1</sub> [kW]	T <sub>2</sub> [Nm]	n <sub>2</sub> [RPM]	P <sub>1</sub> [kW]			T <sub>2</sub> [Nm]
RE 2001		3.83	196	272	12900	235	309	12200	378	431	10600	—	—	—	44100	44 (T) 36 (H) 28 (F)
		5.25	143	210	13700	171	239	13000	276	333	11200	—	—	—	40300	
RE 2002	L	13.80	54	78	13000	65	89	12300	105	124	10700	210	201	8680	44000	25 (T) 21 (H) 16 (F)
		15.33	48.9	96	17700	59	109	16800	95	152	14600	189	246	11800	44100	
		17.42	43.0	86	18100	52	98	17200	83	136	14900	166	222	12100	44100	
		21.00	35.7	61	15600	42.9	73	15400	69	114	15000	138	210	13800	40300	
	L	22.31	33.6	58	15600	40.3	69	15500	65	108	15100	130	176	12300	40300	
	L	28.00	26.8	46.7	15800	32.1	55	15700	52	87	15300	104	146	12800	40300	
	L	32.55	23.0	38.9	15300	27.6	46.2	15200	44.5	72	14800	89	130	13300	40300	
RE 2003	L	39.38	19.0	25.2	12000	22.9	29.9	11900	36.8	47	11600	74	90	11100	33200	18 (T) 15 (H) 12 (F)
		48.02	15.6	27.9	15800	18.7	31.7	15000	30.2	44	13000	60	72	10500	44000	
		55.20	13.6	35.1	22900	16.3	41.7	22700	26.3	63	21400	53	103	17400	44100	
		65.17	11.5	30.0	23100	13.8	35.7	22900	22.3	56	22300	44.5	92	18200	44100	
		74.05	10.1	23.5	20600	12.2	28.0	20400	19.6	43.8	19800	39.2	83	18700	44100	
		81.78	9.2	24.3	23400	11.0	28.8	23200	17.7	45.2	22500	35.5	78	19500	44100	
		92.93	8.1	19.0	20800	9.7	22.6	20600	15.6	35.4	20100	31.2	68	19300	44100	
		101.42	7.4	14.2	17000	8.9	16.9	16900	14.3	26.5	16400	28.6	51	15800	40300	
		112.00	6.7	13.0	17100	8.0	15.4	17000	12.9	24.1	16500	25.9	46.4	15900	40300	
	L	128.73	5.8	11.4	17300	7.0	13.5	17100	11.3	21.2	16600	22.5	40.7	16000	40300	
		147.95	5.1	10.0	17400	6.1	11.8	17200	9.8	18.6	16800	19.6	35.7	16100	40300	
		157.50	4.8	9.4	17500	5.7	11.2	17300	9.2	17.5	16800	18.4	33.7	16200	40300	
	L	178.98	4.2	8.5	17900	5.0	9.9	17400	8.1	15.5	17000	16.2	29.8	16300	40300	
RE 2004	L	201.60	3.7	7.6	18200	4.5	8.9	17700	7.2	13.9	17100	14.4	26.7	16400	40300	14 (T) 12 (H) 10 (F)
		192.10	3.9	11.1	24600	4.7	13.2	24300	7.5	20.7	23700	15.1	39.8	22800	44100	
		226.78	3.3	9.5	24800	4.0	11.3	24600	6.4	17.7	23900	12.8	34.0	23000	44100	
		257.70	2.9	7.5	22100	3.5	8.8	21900	5.6	13.9	21300	11.3	26.7	20500	44100	
		284.59	2.6	7.7	25100	3.2	9.1	24900	5.1	14.3	24200	10.2	27.5	23300	44100	
		315.70	2.4	6.2	22400	2.9	7.3	22100	4.6	11.5	21500	9.2	22.0	20700	44100	
		348.63	2.2	6.3	25400	2.6	7.5	25200	4.2	4.7	24500	8.3	22.7	23500	44100	
		396.17	1.9	5.0	22600	2.3	5.9	22400	3.7	9.2	21800	7.3	17.8	21000	44100	
	L	447.97	1.7	4.0	20500	2.0	4.6	20000	3.2	7.0	18600	6.5	12.9	17200	40100	
	L	500.07	1.5	3.6	20500	1.8	4.2	19900	2.9	6.4	19000	5.8	12.3	18300	40100	
	L	562.15	1.3	3.3	21200	1.6	3.8	20700	2.6	5.7	19200	5.2	10.4	17400	40100	
	L	629.07	1.2	2.8	20100	1.4	3.3	19900	2.3	5.2	19400	4.6	9.4	17600	40100	
	L	701.57	1.1	2.7	22000	1.3	3.2	21400	2.1	4.8	19900	4.1	8.6	17900	40100	
		806.40	0.93	2.4	22400	1.1	2.8	21800	1.8	4.2	20300	3.6	7.6	18300	40300	
		908.65	0.83	2.2	22800	0.99	2.6	22200	1.6	3.8	20700	3.2	6.9	18600	40300	
		1032.56	0.73	2.0	23300	0.87	2.3	22700	1.4	3.4	21100	2.8	6.2	19000	40300	
		1134.00	0.66	1.8	23600	0.79	2.1	23000	1.3	3.2	21400	2.6	5.7	19300	40300	
	1288.64	0.58	1.6	24100	0.70	1.9	23400	1.1	2.8	21800	2.3	5.1	19600	40300		
L	1451.52	0.52	1.3	21700	0.62	1.5	21500	1.0	2.4	20900	2.0	4.6	20000	40100		

		n <sub>1</sub> = 750 RPM			n <sub>1</sub> = 900 RPM			n <sub>1</sub> = 1450 RPM			n <sub>1</sub> = 2900 RPM			T <sub>2max</sub> [Nm]	P <sub>t</sub> [kW]
ie		n <sub>2</sub> [RPM]	P <sub>1</sub> [kW]	T <sub>2</sub> [Nm]	n <sub>2</sub> [RPM]	P <sub>1</sub> [kW]	T <sub>2</sub> [Nm]	n <sub>2</sub> [RPM]	P <sub>1</sub> [kW]	T <sub>2</sub> [Nm]	n <sub>2</sub> [RPM]	P <sub>1</sub> [kW]	T <sub>2</sub> [Nm]		
RA 2002		11.77	64	<b>107</b>	15000	76	<b>121</b>	14200	123	<b>169</b>	12300	246	<b>275</b>	9970	44100
		16.13	46.5	<b>80</b>	15300	56	<b>95</b>	15200	90	<b>149</b>	14800	180	<b>257</b>	12800	40300
		17.89	41.9	<b>54</b>	11500	50	<b>64</b>	11400	81	<b>100</b>	11100	162	<b>191</b>	10500	29600
		24.50	30.6	<b>54</b>	15700	36.7	<b>64</b>	15600	59	<b>100</b>	15100	118	<b>191</b>	14400	40300
RA 2003	L	38.44	19.5	<b>27.1</b>	12400	23.4	<b>31.6</b>	11800	37.7	<b>44.1</b>	10200	75	<b>72</b>	8270	44000
		42.71	17.6	<b>27.1</b>	13800	21.1	<b>31.6</b>	13100	33.9	<b>44.1</b>	11300	68	<b>72</b>	9190	44100
	L	45.38	16.5	<b>27.8</b>	14700	19.8	<b>31.6</b>	13900	31.9	<b>44.1</b>	12000	64	<b>72</b>	9770	44000
	L	52.65	14.2	<b>26.8</b>	16400	17.1	<b>31.6</b>	16100	27.5	<b>44.1</b>	13900	55	<b>72</b>	11300	40300
	L	55.20	13.6	<b>20.6</b>	13200	16.3	<b>23.4</b>	12500	26.3	<b>32.6</b>	10800	53	<b>53</b>	8790	38200
	L	62.16	12.1	<b>22.9</b>	16600	14.5	<b>27.3</b>	16400	23.3	<b>42.7</b>	16000	46.7	<b>72</b>	13400	40300
		69.70	10.8	<b>20.6</b>	16600	12.9	<b>23.4</b>	15800	20.8	<b>32.6</b>	13700	41.6	<b>53.0</b>	11100	44100
	L	78.00	9.6	<b>18.5</b>	16800	11.5	<b>22.0</b>	16600	18.6	<b>34.5</b>	16200	37.2	<b>66</b>	15500	40300
	L	89.25	8.4	<b>16.3</b>	16900	10.1	<b>19.4</b>	16700	16.2	<b>30.4</b>	16300	32.5	<b>53.0</b>	14200	40300
		95.45	7.9	<b>15.3</b>	17000	9.4	<b>18.2</b>	16800	15.2	<b>28.5</b>	16400	30.4	<b>53.0</b>	15200	40300
	L	112.00	6.7	<b>13.2</b>	17100	8.0	<b>15.6</b>	17000	12.9	<b>24.5</b>	16500	25.9	<b>47.1</b>	15900	40300
	L	130.20	5.8	<b>11.0</b>	16600	6.9	<b>13.0</b>	16400	11.1	<b>20.4</b>	16000	22.3	<b>39.3</b>	15400	40300
L	157.50	4.8	<b>7.1</b>	13000	5.7	<b>8.4</b>	12900	9.2	<b>13.2</b>	12500	18.4	<b>25.4</b>	12000	33200	
RA 2004		153.77	4.9	<b>13.9</b>	24300	5.9	<b>16.5</b>	24000	9.4	<b>25.9</b>	23400	18.9	<b>49.9</b>	22500	44100
		181.54	4.1	<b>11.9</b>	24500	5.0	<b>14.1</b>	24200	8.0	<b>22.2</b>	23600	16.0	<b>42.6</b>	22700	44100
		206.29	3.6	<b>9.3</b>	21800	4.4	<b>11.1</b>	21600	7.0	<b>17.4</b>	21000	14.1	<b>33.4</b>	20200	44100
		220.80	3.4	<b>9.9</b>	24800	4.1	<b>11.8</b>	24500	6.6	<b>18.4</b>	23900	13.1	<b>35.4</b>	22900	44100
	L	248.47	3.0	<b>6.7</b>	18800	3.6	<b>7.8</b>	18300	5.8	<b>11.9</b>	17300	11.7	<b>21.2</b>	15500	40300
		282.53	2.7	<b>6.0</b>	19100	3.2	<b>5.8</b>	15200	5.1	<b>10.5</b>	17400	10.3	<b>20.2</b>	16700	40300
	L	311.81	2.4	<b>5.5</b>	19400	3.2	<b>7.0</b>	18600	4.7	<b>9.6</b>	17600	9.3	<b>18.4</b>	16800	40300
	L	348.92	2.1	<b>4.9</b>	19500	2.6	<b>5.8</b>	19200	4.2	<b>8.7</b>	17900	8.3	<b>16.6</b>	16900	40300
	L	411.92	1.8	<b>4.3</b>	20300	2.2	<b>5.1</b>	19700	3.5	<b>7.6</b>	18300	7.0	<b>14.2</b>	17100	40300
		448.00	1.7	<b>4.0</b>	20500	2.0	<b>4.7</b>	20000	3.2	<b>7.1</b>	18600	6.5	<b>13.1</b>	17200	40300
		498.58	1.5	<b>3.7</b>	20900	1.8	<b>4.3</b>	20300	2.9	<b>6.5</b>	18900	5.8	<b>11.8</b>	17300	40300
	L	547.58	1.4	<b>2.2</b>	13400	1.6	<b>2.6</b>	13300	2.6	<b>4.0</b>	12900	5.3	<b>7.7</b>	12400	30900
		591.82	1.3	<b>3.2</b>	21400	1.5	<b>3.7</b>	20800	2.5	<b>5.6</b>	19400	4.9	<b>10.1</b>	17500	40300
		630.00	1.2	<b>3.0</b>	21600	1.4	<b>3.5</b>	21000	2.3	<b>5.3</b>	19600	4.6	<b>9.5</b>	17600	40300
		715.91	1.0	<b>2.7</b>	22000	1.3	<b>3.2</b>	21400	2.0	<b>4.8</b>	19900	4.1	<b>8.6</b>	18000	40300
	L	907.20	0.83	<b>1.4</b>	14400	1.0	<b>1.7</b>	14200	1.6	<b>2.6</b>	13800	3.2	<b>5.0</b>	13300	33200

	ie	n <sub>1</sub> = 750 RPM			n <sub>1</sub> = 900 RPM			n <sub>1</sub> = 1450 RPM			n <sub>1</sub> = 2900 RPM			T <sub>2max</sub> [Nm]	P <sub>t</sub> [kW]
		n <sub>2</sub> [RPM]	P <sub>1</sub> [kW]	T <sub>2</sub> [Nm]	n <sub>2</sub> [RPM]	P <sub>1</sub> [kW]	T <sub>2</sub> [Nm]	n <sub>2</sub> [RPM]	P <sub>1</sub> [kW]	T <sub>2</sub> [Nm]	n <sub>2</sub> [RPM]	P <sub>1</sub> [kW]	T <sub>2</sub> [Nm]		
<b>RE 2521</b>	<b>4.00</b>	188	<b>294</b>	14600	225	<b>334</b>	13800	363	<b>467</b>	12000	—	—	—	63000	46 (H) 41 (F)
	<b>5.20</b>	144	<b>238</b>	15300	173	<b>270</b>	14500	279	<b>377</b>	12600	—	—	—	50100	
	<b>6.25</b>	120	<b>184</b>	14300	144	<b>218</b>	14100	232	<b>327</b>	13100	—	—	—	39300	
<b>RE 2522</b>	<b>14.25</b>	53	<b>97</b>	16800	63	<b>111</b>	15900	102	<b>154</b>	13800	—	—	—	47700	26 (H) 24 (F)
	<b>16.62</b>	45.1	<b>86</b>	17300	54	<b>98</b>	16400	87	<b>136</b>	14200	—	—	—	47700	
	<b>18.53</b>	40.5	<b>87</b>	19600	48.6	<b>104</b>	19400	78	<b>154</b>	17900	—	—	—	50100	
	<b>21.60</b>	34.7	<b>76</b>	19700	41.7	<b>90</b>	19500	67	<b>136</b>	18400	—	—	—	50100	
	<b>26.52</b>	28.3	<b>62</b>	20000	33.9	<b>74</b>	19800	55	<b>115</b>	19200	—	—	—	50100	
	<b>30.28</b>	24.8	<b>55</b>	20100	29.7	<b>65</b>	19900	47.9	<b>102</b>	19400	—	—	—	50100	
	<b>35.66</b>	21.0	<b>45.3</b>	19600	25.2	<b>54</b>	19400	40.7	<b>84</b>	18800	—	—	—	50100	
	<b>42.86</b>	17.5	<b>30.7</b>	15900	21.0	<b>36.5</b>	15800	33.8	<b>57</b>	15300	—	—	—	39300	
<b>RE 2523</b>	<b>51.30</b>	14.6	<b>40.7</b>	24600	17.5	<b>46.2</b>	23300	28.3	<b>65</b>	20200	57	<b>105</b>	16400	47700	19 (H) 17 (F)
	<b>59.82</b>	12.5	<b>36.0</b>	25400	15.0	<b>40.9</b>	24000	24.2	<b>57</b>	20800	48.5	<b>93</b>	16900	47700	
	<b>60.56</b>	12.4	<b>36.2</b>	25900	14.9	<b>41.2</b>	24500	23.9	<b>57</b>	21300	47.9	<b>93</b>	17300	47700	
	<b>70.62</b>	10.6	<b>31.8</b>	26500	12.7	<b>36.4</b>	25300	20.5	<b>51</b>	21900	41.1	<b>83</b>	17800	47700	
	<b>78.73</b>	9.5	<b>22.9</b>	21300	11.4	<b>27.2</b>	21000	18.4	<b>42.6</b>	20500	36.8	<b>82</b>	19700	50100	
	<b>86.70</b>	8.7	<b>21.8</b>	22300	10.4	<b>25.9</b>	22100	16.7	<b>40.6</b>	21500	33.4	<b>70</b>	18500	47700	
	<b>103.02</b>	7.3	<b>19.3</b>	23500	8.7	<b>22.9</b>	23300	14.1	<b>36.0</b>	22600	28.2	<b>63</b>	19900	47700	
	<b>112.71</b>	6.7	<b>16.3</b>	21700	8.0	<b>19.4</b>	21500	12.9	<b>30.4</b>	20900	25.7	<b>58</b>	20100	50100	
	<b>128.70</b>	5.8	<b>14.6</b>	22100	7.0	<b>17.1</b>	21600	11.3	<b>26.8</b>	21100	22.5	<b>52</b>	20200	50100	
	<b>141.44</b>	5.3	<b>13.4</b>	22400	6.4	<b>15.7</b>	21800	10.3	<b>24.5</b>	21200	20.5	<b>47.1</b>	20400	50100	
	<b>164.42</b>	4.6	<b>11.8</b>	23000	5.5	<b>13.8</b>	22300	8.8	<b>21.3</b>	21400	17.6	<b>40.9</b>	20500	50100	
	<b>187.75</b>	4.0	<b>10.6</b>	23400	4.8	<b>12.3</b>	22800	7.7	<b>18.8</b>	21500	15.4	<b>36.1</b>	20700	50100	
	<b>198.90</b>	3.8	<b>10.1</b>	23600	4.5	<b>11.8</b>	23000	7.3	<b>17.8</b>	21600	14.6	<b>34.2</b>	20800	50100	
	<b>221.07</b>	3.4	<b>8.3</b>	21700	4.1	<b>9.9</b>	21500	6.6	<b>15.5</b>	20900	13.1	<b>29.8</b>	20100	50100	
	<b>239.06</b>	3.1	<b>6.5</b>	18500	3.8	<b>7.6</b>	18000	6.1	<b>11.6</b>	16900	12.1	<b>22.3</b>	16300	39300	
<b>267.43</b>	2.8	<b>7.0</b>	21900	3.4	<b>8.3</b>	21700	5.4	<b>12.9</b>	21100	10.8	<b>24.9</b>	20300	50100		
<b>321.43</b>	2.3	<b>5.1</b>	19300	2.8	<b>5.9</b>	18800	4.5	<b>8.9</b>	17500	9.0	<b>16.9</b>	16500	39300		
<b>RE 2524</b>	<b>210.76</b>	3.6	<b>13.0</b>	31400	4.3	<b>15.4</b>	31100	6.9	<b>23.7</b>	29700	13.8	<b>40.0</b>	25100	47700	15 (H) 14 (F)
	<b>218.70</b>	3.4	<b>12.7</b>	32100	4.1	<b>15.1</b>	31800	6.6	<b>21.7</b>	28200	13.3	<b>35.2</b>	22900	47700	
	<b>245.74</b>	3.1	<b>10.1</b>	28500	3.7	<b>12.0</b>	28200	5.9	<b>18.7</b>	27400	11.8	<b>35.4</b>	25900	47700	
	<b>301.04</b>	2.5	<b>8.3</b>	28800	3.0	<b>9.9</b>	28500	4.8	<b>15.5</b>	27700	9.6	<b>29.8</b>	26700	47700	
	<b>308.38</b>	2.4	<b>8.1</b>	28800	2.9	<b>9.7</b>	28500	4.7	<b>15.1</b>	27800	9.4	<b>29.1</b>	26700	47700	
	<b>345.09</b>	2.2	<b>7.2</b>	28600	2.6	<b>8.5</b>	28300	4.2	<b>13.4</b>	27500	8.4	<b>25.7</b>	26400	47700	
	<b>407.40</b>	1.8	<b>6.4</b>	29800	2.2	<b>7.4</b>	29000	3.6	<b>11.6</b>	28200	7.1	<b>22.4</b>	27100	47700	
	<b>448.62</b>	1.7	<b>5.2</b>	26700	2.0	<b>6.0</b>	26000	3.2	<b>9.1</b>	24200	6.5	<b>16.3</b>	21800	50100	
	<b>500.19</b>	1.5	<b>4.3</b>	24900	1.8	<b>5.1</b>	24400	2.9	<b>8.0</b>	23700	5.8	<b>15.3</b>	22800	47700	
	<b>550.80</b>	1.4	<b>4.4</b>	27600	1.6	<b>5.1</b>	26800	2.6	<b>7.6</b>	25000	5.3	<b>13.7</b>	22500	50100	
	<b>638.03</b>	1.2	<b>4.1</b>	30400	1.4	<b>4.9</b>	30000	2.3	<b>7.6</b>	28900	4.5	<b>14.7</b>	27800	47700	
	<b>711.36</b>	1.1	<b>3.5</b>	28700	1.3	<b>4.1</b>	27900	2.0	<b>6.1</b>	25900	4.1	<b>11.0</b>	23400	50100	
	<b>800.41</b>	0.94	<b>3.0</b>	27800	1.1	<b>3.5</b>	27100	1.8	<b>5.5</b>	26400	3.6	<b>10.0</b>	23800	50100	
	<b>910.66</b>	0.82	<b>2.6</b>	27300	0.99	<b>3.0</b>	26600	1.6	<b>4.6</b>	24700	3.2	<b>8.7</b>	23600	47700	
	<b>1018.37</b>	0.74	<b>2.6</b>	30300	0.88	<b>3.0</b>	29400	1.4	<b>4.5</b>	27400	2.8	<b>8.1</b>	24700	50100	
	<b>1147.50</b>	0.65	<b>2.3</b>	30800	0.78	<b>2.7</b>	30000	1.3	<b>4.1</b>	27900	2.5	<b>7.4</b>	25100	50100	
	<b>1310.29</b>	0.57	<b>2.0</b>	30000	0.69	<b>2.3</b>	29200	1.1	<b>3.5</b>	27100	2.2	<b>6.6</b>	25600	50100	
	<b>1432.08</b>	0.52	<b>1.9</b>	31900	0.63	<b>2.3</b>	31000	1.0	<b>3.4</b>	28800	2.0	<b>6.1</b>	26000	50100	
<b>1635.25</b>	0.46	<b>1.6</b>	31000	0.55	<b>1.9</b>	30200	0.89	<b>2.9</b>	28100	1.8	<b>5.4</b>	26400	50100		
<b>1925.49</b>	0.39	<b>1.2</b>	26600	0.47	<b>1.4</b>	25900	0.75	<b>2.1</b>	24100	1.5	<b>4.0</b>	22700	50100		

	ie	n <sub>1</sub> = 750 RPM			n <sub>1</sub> = 900 RPM			n <sub>1</sub> = 1450 RPM			n <sub>1</sub> = 2900 RPM			T <sub>2max</sub> [Nm]	P <sub>t</sub> [kW]
		n <sub>2</sub> [RPM]	P <sub>1</sub> [kW]	T <sub>2</sub> [Nm]	n <sub>2</sub> [RPM]	P <sub>1</sub> [kW]	T <sub>2</sub> [Nm]	n <sub>2</sub> [RPM]	P <sub>1</sub> [kW]	T <sub>2</sub> [Nm]	n <sub>2</sub> [RPM]	P <sub>1</sub> [kW]	T <sub>2</sub> [Nm]		
<b>RA 2522</b>	<b>12.29</b>	61	<b>107</b>	15600	73	<b>121</b>	14800	118	<b>169</b>	12800	236	<b>275</b>	10400	48300	24 (H) 22 (F)
	<b>15.97</b>	47.0	<b>102</b>	19400	56	<b>121</b>	19200	91	<b>169</b>	16700	182	<b>275</b>	13500	50100	
	<b>19.20</b>	39.1	<b>66</b>	15200	48.2	<b>64</b>	11900	76	<b>124</b>	14600	151	<b>238</b>	14100	39300	
	<b>24.27</b>	30.9	<b>54</b>	15600	37.1	<b>64</b>	15400	60	<b>100</b>	15000	120	<b>191</b>	14300	40200	
	<b>29.17</b>	25.7	<b>44.8</b>	15600	30.9	<b>53</b>	15400	49.7	<b>83</b>	15000	99	<b>160</b>	14400	39300	
<b>RA 2523</b>	<b>41.65</b>	18.0	<b>47.8</b>	23100	21.6	<b>54</b>	21900	34.8	<b>76</b>	19000	70	<b>123</b>	15400	57300	18 (H) 17 (F)
	<b>44.01</b>	17.0	<b>42.3</b>	21600	20.4	<b>48.0</b>	20500	32.9	<b>67</b>	17700	66	<b>109</b>	14400	51900	
	<b>51.66</b>	14.5	<b>38.4</b>	23000	17.4	<b>43.6</b>	21800	28.1	<b>61</b>	18900	56	<b>99</b>	15400	51900	
	<b>57.00</b>	13.2	<b>38.4</b>	25400	15.8	<b>43.6</b>	24100	25.4	<b>61</b>	20900	51	<b>99</b>	17000	57300	
	<b>66.46</b>	11.3	<b>33.9</b>	26200	13.5	<b>38.5</b>	24800	21.8	<b>54</b>	21500	43.6	<b>87</b>	17500	57300	
	<b>68.09</b>	11.0	<b>23.5</b>	18600	13.2	<b>27.9</b>	18400	21.3	<b>43.7</b>	17900	42.6	<b>83</b>	17000	57300	
	<b>81.60</b>	9.2	<b>23.4</b>	22200	11.0	<b>27.8</b>	22000	17.8	<b>43.6</b>	21400	35.5	<b>74</b>	18200	57300	
	<b>88.52</b>	8.5	<b>20.8</b>	21400	10.2	<b>24.7</b>	21200	16.4	<b>38.7</b>	20600	32.8	<b>74</b>	19800	50100	
	<b>103.85</b>	7.2	<b>13.9</b>	16700	8.7	<b>16.5</b>	16600	14.0	<b>25.8</b>	16100	27.9	<b>49.7</b>	15500	39300	
	<b>109.71</b>	6.8	<b>12.8</b>	16300	8.2	<b>15.2</b>	16100	13.2	<b>23.8</b>	15700	26.4	<b>45.7</b>	15100	41500	
	<b>125.27</b>	6.0	<b>11.6</b>	16900	7.2	<b>13.8</b>	16800	11.6	<b>21.7</b>	16300	23.1	<b>41.6</b>	15700	39300	
	<b>142.63</b>	5.3	<b>12.8</b>	21200	6.3	<b>15.2</b>	21000	10.2	<b>23.8</b>	20400	20.3	<b>45.7</b>	19600	50100	
	<b>171.43</b>	4.4	<b>8.8</b>	17500	5.3	<b>10.3</b>	17100	8.5	<b>16.1</b>	16600	16.9	<b>31.0</b>	16000	39300	
<b>RA 2524</b>	<b>129.51</b>	5.8	<b>17.8</b>	26200	6.9	<b>20.8</b>	25400	11.2	<b>31.4</b>	23800	22.4	<b>53</b>	20200	51900	14 (H) 13 (F)
	<b>142.91</b>	5.2	<b>19.1</b>	31000	6.3	<b>22.3</b>	30100	10.1	<b>32.8</b>	27500	20.3	<b>53</b>	22300	57300	
	<b>152.89</b>	4.9	<b>15.5</b>	26800	5.9	<b>18.1</b>	26100	9.5	<b>27.1</b>	24300	19.0	<b>47.5</b>	21300	51900	
	<b>196.71</b>	3.8	<b>12.6</b>	28100	4.6	<b>15.0</b>	27800	7.4	<b>23.5</b>	27100	14.7	<b>42.0</b>	24200	57300	
	<b>219.54</b>	3.4	<b>11.4</b>	28300	4.1	<b>13.3</b>	27600	6.6	<b>19.9</b>	25600	13.2	<b>36.7</b>	23600	51900	
	<b>255.98</b>	2.9	<b>9.0</b>	26000	3.5	<b>10.6</b>	25700	5.7	<b>16.7</b>	25000	11.3	<b>31.7</b>	23800	51900	
	<b>282.46</b>	2.7	<b>9.0</b>	28700	3.2	<b>10.6</b>	28400	5.1	<b>16.7</b>	27600	10.3	<b>32.1</b>	26600	57300	
	<b>314.93</b>	2.4	<b>7.1</b>	25300	2.9	<b>8.3</b>	24600	4.6	<b>12.4</b>	22900	9.2	<b>23.1</b>	21300	50100	
	<b>354.46</b>	2.1	<b>7.3</b>	29200	2.5	<b>8.6</b>	28800	4.1	<b>13.5</b>	28000	8.2	<b>25.9</b>	26900	57300	
	<b>395.20</b>	1.9	<b>5.9</b>	26200	2.3	<b>6.8</b>	25500	3.7	<b>10.2</b>	23700	7.3	<b>18.6</b>	21600	50100	
	<b>449.91</b>	1.7	<b>5.2</b>	26500	2.0	<b>6.1</b>	26000	3.2	<b>9.2</b>	24200	6.4	<b>16.5</b>	21800	50100	
	<b>505.92</b>	1.5	<b>4.4</b>	25000	1.8	<b>5.1</b>	24400	2.9	<b>8.0</b>	23800	5.7	<b>15.4</b>	22800	57300	
	<b>565.76</b>	1.3	<b>4.3</b>	27700	1.6	<b>5.0</b>	26900	2.6	<b>7.6</b>	25100	5.1	<b>13.6</b>	22600	50100	
	<b>632.68</b>	1.2	<b>3.8</b>	27000	1.4	<b>4.5</b>	26800	2.3	<b>6.9</b>	25500	4.6	<b>12.4</b>	22900	50100	
	<b>698.82</b>	1.1	<b>2.8</b>	21800	1.3	<b>3.2</b>	21200	2.1	<b>5.0</b>	20400	4.1	<b>9.6</b>	19700	57300	
	<b>795.60</b>	0.94	<b>3.2</b>	29200	1.1	<b>3.8</b>	28400	1.8	<b>5.7</b>	26400	3.6	<b>10.2</b>	23800	50100	
	<b>884.30</b>	0.85	<b>2.4</b>	23700	1.0	<b>2.8</b>	23300	1.6	<b>4.4</b>	22600	3.3	<b>8.4</b>	21700	50100	
	<b>956.25</b>	0.78	<b>2.1</b>	22800	0.94	<b>2.5</b>	22100	1.5	<b>3.7</b>	20600	3.0	<b>6.6</b>	18500	39300	
	<b>1091.91</b>	0.69	<b>1.9</b>	23200	0.82	<b>2.2</b>	22600	1.3	<b>3.3</b>	21000	2.7	<b>5.9</b>	18900	39300	

	ie	n <sub>1</sub> = 750 RPM			n <sub>1</sub> = 900 RPM			n <sub>1</sub> = 1450 RPM			n <sub>1</sub> = 2900 RPM			T <sub>2max</sub> [Nm]	P <sub>t</sub> [kW]
		n <sub>2</sub> [RPM]	P <sub>1</sub> [kW]	T <sub>2</sub> [Nm]	n <sub>2</sub> [RPM]	P <sub>1</sub> [kW]	T <sub>2</sub> [Nm]	n <sub>2</sub> [RPM]	P <sub>1</sub> [kW]	T <sub>2</sub> [Nm]	n <sub>2</sub> [RPM]	P <sub>1</sub> [kW]	T <sub>2</sub> [Nm]		
<b>RE 3001</b>	<b>4.00</b>	188	<b>392</b>	19500	225	<b>446</b>	18500	363	<b>623</b>	16000	—	—	—	78800	46 (H)
	<b>4.71</b>	159	<b>344</b>	20100	191	<b>390</b>	19000	308	<b>545</b>	16500	—	—	—	71700	41 (F)
<b>RE 3002</b>	<b>14.25</b>	53	<b>133</b>	23000	63	<b>152</b>	21800	102	<b>212</b>	18900	—	—	—	78800	27 (H) 24 (F)
	<b>16.62</b>	45.1	<b>118</b>	23700	54	<b>134</b>	22400	87	<b>187</b>	19400	—	—	—	78800	
	<b>19.55</b>	38.4	<b>118</b>	27900	46.0	<b>134</b>	26400	74	<b>187</b>	22900	—	—	—	71700	
	<b>23.29</b>	32.2	<b>90</b>	25300	38.6	<b>102</b>	24000	62	<b>143</b>	20800	—	—	—	69600	
	<b>24.00</b>	31.3	<b>97</b>	28200	37.5	<b>113</b>	27400	60	<b>158</b>	23800	—	—	—	71700	
	<b>27.40</b>	27.4	<b>86</b>	28400	32.8	<b>102</b>	28100	53	<b>143</b>	24500	—	—	—	71700	
	<b>32.27</b>	23.2	<b>66</b>	25600	27.9	<b>78</b>	25300	44.9	<b>122</b>	24700	—	—	—	70600	
<b>RE 3003</b>	<b>51.30</b>	14.6	<b>56</b>	33800	17.5	<b>63</b>	32000	28.3	<b>89</b>	27700	57	<b>144</b>	22500	78800	19 (H) 18 (F)
	<b>60.56</b>	12.4	<b>49.7</b>	35500	14.9	<b>56</b>	33600	23.9	<b>79</b>	29100	47.9	<b>128</b>	23700	78800	
	<b>76.00</b>	9.9	<b>40.4</b>	36200	11.8	<b>48.0</b>	35900	19.1	<b>67</b>	31200	38.2	<b>109</b>	25300	78800	
	<b>88.62</b>	8.5	<b>35.0</b>	36600	10.2	<b>41.5</b>	36200	16.4	<b>59</b>	32100	32.7	<b>96</b>	26100	78800	
	<b>103.02</b>	7.3	<b>30.3</b>	36900	8.7	<b>36.0</b>	36500	14.1	<b>53</b>	33600	28.2	<b>87</b>	27300	78800	
	<b>108.80</b>	6.9	<b>25.4</b>	32700	8.3	<b>30.2</b>	32300	13.3	<b>47.4</b>	31500	26.7	<b>81.7</b>	27100	78800	
	<b>124.62</b>	6.0	<b>25.7</b>	37800	7.2	<b>30.1</b>	36900	11.6	<b>46.8</b>	35600	23.3	<b>76.0</b>	28900	78800	
	<b>144.42</b>	5.2	<b>16.5</b>	28100	6.2	<b>19.6</b>	27800	10.0	<b>30.7</b>	27000	20.1	<b>58.9</b>	26000	69600	
	<b>153.00</b>	4.9	<b>18.4</b>	33300	5.9	<b>21.9</b>	33000	9.5	<b>34.4</b>	32100	19.0	<b>64.4</b>	30100	78800	
	<b>180.00</b>	4.2	<b>15.3</b>	32600	5.0	<b>17.9</b>	31700	8.1	<b>27.7</b>	30500	16.1	<b>53.3</b>	29300	71700	
	<b>205.54</b>	3.6	<b>13.7</b>	33200	4.4	<b>16.0</b>	32300	7.1	<b>24.5</b>	30700	14.1	<b>47.0</b>	29500	71700	
	<b>242.02</b>	3.1	<b>10.1</b>	28700	3.7	<b>11.9</b>	28400	6.0	<b>18.7</b>	27700	12.0	<b>36.0</b>	26600	70600	
<b>RE 3004</b>	<b>178.52</b>	4.2	<b>19.4</b>	39900	5.0	<b>22.7</b>	38800	8.1	<b>34.5</b>	36700	16.2	<b>61.6</b>	32700	78800	15 (H) 14 (F)
	<b>208.16</b>	3.6	<b>17.0</b>	40800	4.3	<b>19.9</b>	39700	7.0	<b>29.8</b>	37000	13.9	<b>54.4</b>	33700	78800	
	<b>218.70</b>	3.4	<b>16.3</b>	41100	4.1	<b>19.1</b>	40000	6.6	<b>28.6</b>	37200	13.3	<b>53.4</b>	34800	78800	
	<b>255.00</b>	2.9	<b>14.1</b>	41300	3.5	<b>16.7</b>	40900	5.7	<b>25.1</b>	38100	11.4	<b>47.2</b>	35800	78800	
	<b>289.11</b>	2.6	<b>10.5</b>	35000	3.1	<b>12.3</b>	34000	5.0	<b>18.4</b>	31700	10.0	<b>35.0</b>	30100	71700	
	<b>324.00</b>	2.3	<b>11.7</b>	43700	2.8	<b>13.7</b>	42500	4.5	<b>20.5</b>	39500	9.0	<b>37.8</b>	36400	78800	
	<b>349.40</b>	2.1	<b>11.0</b>	44200	2.6	<b>12.8</b>	43000	4.1	<b>19.2</b>	40000	8.3	<b>35.2</b>	36600	78800	
	<b>381.18</b>	2.0	<b>8.3</b>	36500	2.4	<b>9.7</b>	35500	3.8	<b>14.5</b>	33000	7.6	<b>27.0</b>	30600	71700	
	<b>439.17</b>	1.7	<b>8.6</b>	43600	2.0	<b>10.1</b>	42500	3.3	<b>15.7</b>	41000	6.6	<b>28.5</b>	37300	78800	
	<b>508.43</b>	1.5	<b>7.6</b>	44600	1.8	<b>8.9</b>	43400	2.9	<b>13.7</b>	41400	5.7	<b>25.2</b>	38100	78800	
	<b>569.18</b>	1.3	<b>5.4</b>	35400	1.6	<b>6.4</b>	35000	2.5	<b>10.1</b>	34100	5.1	<b>18.6</b>	31600	71700	
	<b>636.12</b>	1.2	<b>6.4</b>	46600	1.4	<b>7.6</b>	46100	2.3	<b>11.6</b>	43800	4.6	<b>20.8</b>	39400	78800	
	<b>699.20</b>	1.1	<b>5.0</b>	40000	1.3	<b>5.8</b>	38900	2.1	<b>8.7</b>	36200	4.1	<b>15.7</b>	32600	71700	
	<b>783.36</b>	0.96	<b>4.3</b>	38600	1.1	<b>5.0</b>	37500	1.9	<b>7.6</b>	35200	3.7	<b>14.5</b>	33900	78800	
	<b>897.23</b>	0.84	<b>4.1</b>	42600	1.0	<b>4.9</b>	42100	1.6	<b>7.7</b>	41000	3.2	<b>14.8</b>	39400	78800	
	<b>1007.92</b>	0.74	<b>2.9</b>	33400	0.89	<b>3.4</b>	32500	1.4	<b>5.0</b>	30200	2.9	<b>9.7</b>	29000	69600	
	<b>1101.60</b>	0.68	<b>3.2</b>	40600	0.82	<b>3.7</b>	39500	1.3	<b>5.6</b>	36800	2.6	<b>10.5</b>	34500	78800	
<b>1257.88</b>	0.60	<b>2.4</b>	34500	0.72	<b>2.8</b>	33600	1.2	<b>4.2</b>	31200	2.3	<b>7.9</b>	29400	69600		
<b>1396.25</b>	0.54	<b>2.1</b>	33700	0.64	<b>2.4</b>	32800	1.0	<b>3.7</b>	30600	2.1	<b>7.1</b>	29400	70600		
<b>1742.52</b>	0.43	<b>1.7</b>	34800	0.52	<b>2.0</b>	33900	0.83	<b>3.0</b>	31500	1.7	<b>5.7</b>	29800	70600		

	ie	n <sub>1</sub> = 750 RPM			n <sub>1</sub> = 900 RPM			n <sub>1</sub> = 1450 RPM			n <sub>1</sub> = 2900 RPM			T <sub>2max</sub> [Nm]	P <sub>t</sub> [kW]
		n <sub>2</sub> [RPM]	P <sub>1</sub> [kW]	T <sub>2</sub> [Nm]	n <sub>2</sub> [RPM]	P <sub>1</sub> [kW]	T <sub>2</sub> [Nm]	n <sub>2</sub> [RPM]	P <sub>1</sub> [kW]	T <sub>2</sub> [Nm]	n <sub>2</sub> [RPM]	P <sub>1</sub> [kW]	T <sub>2</sub> [Nm]		
<b>RA 3002</b>	<b>12.29</b>	61	<b>107</b>	15600	73	<b>121</b>	14800	118	<b>169</b>	12800	236	<b>275</b>	10400	48300	24 (H) 22 (F)
	<b>14.45</b>	52	<b>107</b>	18400	62	<b>121</b>	17400	100	<b>169</b>	15100	201	<b>275</b>	12200	56900	
	<b>18.67</b>	40.2	<b>54</b>	12000	48.2	<b>64</b>	11900	78	<b>100</b>	11500	155	<b>191</b>	11000	30900	
	<b>21.96</b>	34.2	<b>54</b>	14100	41.0	<b>64</b>	14000	66	<b>100</b>	13600	132	<b>191</b>	12900	36400	
<b>RA 3003</b>	<b>41.65</b>	18.0	<b>66</b>	31700	21.6	<b>74</b>	30000	34.8	<b>104</b>	26000	70	<b>169</b>	21100	78800	15 (H) 17 (F)
	<b>48.57</b>	15.4	<b>58</b>	32700	18.5	<b>66</b>	31000	29.9	<b>92</b>	26800	60	<b>149</b>	21800	78800	
	<b>57.00</b>	13.2	<b>52.6</b>	34900	15.8	<b>60</b>	33000	25.4	<b>84</b>	28600	51	<b>136</b>	23200	78800	
	<b>66.46</b>	11.3	<b>46.5</b>	35900	13.5	<b>53</b>	34000	21.8	<b>74</b>	29500	43.6	<b>120</b>	23900	78800	
	<b>70.15</b>	10.7	<b>36.8</b>	30000	12.8	<b>43.7</b>	29700	20.7	<b>68</b>	28900	41.3	<b>126</b>	26700	71700	
	<b>78.19</b>	9.6	<b>33.2</b>	30200	11.5	<b>39.4</b>	29900	18.5	<b>62</b>	29100	37.1	<b>119</b>	27900	71700	
	<b>93.18</b>	8.0	<b>25.3</b>	27400	9.7	<b>30.0</b>	27100	15.6	<b>47.1</b>	26400	31.1	<b>90</b>	25300	69600	
	<b>109.62</b>	6.8	<b>24.1</b>	30800	8.2	<b>28.7</b>	30400	13.2	<b>45.0</b>	29600	26.5	<b>86</b>	28500	71700	
	<b>129.08</b>	5.8	<b>18.5</b>	27700	7.0	<b>21.9</b>	27400	11.2	<b>34.4</b>	26700	22.5	<b>66</b>	25700	70600	
<b>RA 3004</b>	<b>142.91</b>	5.2	<b>23.2</b>	38600	6.3	<b>27.8</b>	37500	10.1	<b>43.2</b>	36200	20.3	<b>73</b>	30600	78800	14 (H) 13 (F)
	<b>166.63</b>	4.5	<b>20.4</b>	39500	5.4	<b>24.4</b>	38400	8.7	<b>37.4</b>	36500	17.4	<b>65</b>	31500	78800	
	<b>196.71</b>	3.8	<b>17.7</b>	40500	4.6	<b>21.2</b>	39400	7.4	<b>32.0</b>	36900	14.7	<b>58</b>	33200	78800	
	<b>231.43</b>	3.2	<b>12.6</b>	33800	3.9	<b>15.1</b>	32900	6.3	<b>22.8</b>	30900	12.5	<b>43.8</b>	29700	71700	
	<b>246.86</b>	3.0	<b>14.4</b>	41200	3.7	<b>17.5</b>	40700	5.9	<b>26.2</b>	37900	11.7	<b>49.1</b>	35500	71700	
	<b>282.46</b>	2.7	<b>12.7</b>	41600	3.2	<b>15.4</b>	41100	5.1	<b>23.4</b>	38700	10.3	<b>43.7</b>	36200	78800	
	<b>304.00</b>	2.5	<b>12.2</b>	43200	3.0	<b>14.7</b>	42100	4.8	<b>22.0</b>	39100	9.5	<b>40.8</b>	36300	78800	
	<b>347.14</b>	2.2	<b>10.0</b>	40300	2.6	<b>12.2</b>	39900	4.2	<b>19.1</b>	38800	8.4	<b>36.0</b>	36600	78800	
	<b>407.16</b>	1.8	<b>7.3</b>	34700	2.2	<b>8.9</b>	34300	3.6	<b>14.0</b>	33300	7.1	<b>19.7</b>	23500	71700	
	<b>435.20</b>	1.7	<b>7.0</b>	35400	2.1	<b>8.5</b>	35000	3.3	<b>13.4</b>	34100	6.7	<b>25.7</b>	32700	78800	
	<b>502.94</b>	1.5	<b>6.5</b>	38000	1.8	<b>7.8</b>	37000	2.9	<b>11.7</b>	34400	5.8	<b>21.1</b>	31100	71700	
	<b>572.57</b>	1.3	<b>5.3</b>	35400	1.6	<b>6.5</b>	35000	2.5	<b>10.2</b>	34100	5.1	<b>18.8</b>	31600	71700	
	<b>612.00</b>	1.2	<b>5.2</b>	37200	1.5	<b>6.3</b>	36200	2.4	<b>9.7</b>	34700	4.7	<b>18.6</b>	33400	78800	
	<b>720.00</b>	1.0	<b>4.8</b>	40100	1.3	<b>5.7</b>	39100	2.0	<b>8.6</b>	36300	4.0	<b>15.5</b>	32700	71700	
	<b>800.27</b>	0.94	<b>3.3</b>	31000	1.1	<b>4.0</b>	30400	1.8	<b>6.3</b>	29600	3.6	<b>12.1</b>	28500	70600	
	<b>968.07</b>	0.77	<b>2.8</b>	31900	0.93	<b>3.4</b>	31000	1.5	<b>5.3</b>	29900	3.0	<b>10.1</b>	28800	70600	

	ie	n <sub>1</sub> = 750 RPM			n <sub>1</sub> = 900 RPM			n <sub>1</sub> = 1450 RPM			n <sub>1</sub> = 2900 RPM			T <sub>2max</sub> [Nm]	P <sub>t</sub> [kW]
		n <sub>2</sub> [RPM]	P <sub>1</sub> [kW]	T <sub>2</sub> [Nm]	n <sub>2</sub> [RPM]	P <sub>1</sub> [kW]	T <sub>2</sub> [Nm]	n <sub>2</sub> [RPM]	P <sub>1</sub> [kW]	T <sub>2</sub> [Nm]	n <sub>2</sub> [RPM]	P <sub>1</sub> [kW]	T <sub>2</sub> [Nm]		
RE 3511	3.84	195	451	21500	234	512	20300	378	715	17600	—	—	—	96500	53 (H) 54 (F)
	4.74	158	379	22300	190	431	21100	306	602	18300	—	—	—	79800	
	5.44	138	340	22900	166	386	21700	267	539	18800	—	—	—	64100	
	6.46	116	253	20300	139	301	20100	224	467	19400	—	—	—	56000	
RE 3512	13.68	55	133	22100	66	152	20900	106	212	18100	—	—	—	96500	31 (H) 31 (F)
	16.88	44.4	133	27200	53	152	25800	86	212	22400	—	—	—	79800	
	19.68	38.1	118	28100	45.7	134	26600	74	187	23000	—	—	—	79800	
	22.59	33.2	92	25300	39.8	110	25000	64	172	24300	—	—	—	64100	
	24.16	31.0	100	29200	37.3	113	27600	60	158	23900	—	—	—	79800	
	27.73	27.0	76	25600	32.5	90	25300	52	142	24600	—	—	—	64100	
	31.67	23.7	67	25800	28.4	80	25500	45.8	125	24800	—	—	—	64100	
	37.29	20.1	58	26000	24.1	68	25700	38.9	107	25000	—	—	—	64100	
44.31	16.9	42	22700	20.3	50	22400	32.7	79	21800	—	—	—	56000		
RE 3513	49.25	15.2	56	32400	18.3	63	30700	29.4	89	26600	59	144	21600	96500	22 (H) 22 (F)
	58.14	12.9	49.7	34100	15.5	56	32300	24.9	79	28000	49.9	128	22700	96500	
	60.75	12.3	46.9	33600	14.8	56	33300	23.9	87	32400	47.7	144	26700	79800	
	72.96	10.3	42.4	36500	12.3	48.1	34500	19.9	67	29900	39.7	109	24300	96500	
	82.33	9.1	28.0	27200	10.9	33.3	26900	17.6	52	26200	35.2	100	25200	64100	
	90.00	8.3	32.4	34400	10.0	38.4	34000	16.1	60	33100	32.2	109	30000	79800	
	98.89	7.6	32.3	37700	9.1	38.3	37200	14.7	53	32300	29.3	87	26200	92900	
	104.94	7.1	28.1	34800	8.6	33.3	34300	13.8	52	33400	27.6	96	30900	79800	
	121.99	6.1	24.7	35600	7.4	28.9	34600	11.9	45.2	33700	23.8	87	32300	79800	
	149.78	5.0	20.8	36700	6.0	24.3	35700	9.7	37.3	34100	19.4	72	32800	79800	
	168.88	4.4	14.7	29300	5.3	17.1	28500	8.6	26.5	27300	17.2	51	26200	64100	
	181.18	4.1	17.7	37800	5.0	20.6	36800	8.0	31.2	34500	16.0	60	33100	79800	
	207.98	3.6	12.3	30200	4.3	14.4	29400	7.0	21.8	27600	13.9	41.8	26600	64100	
	237.49	3.2	11.0	30800	3.8	12.8	30000	6.1	19.2	27900	12.2	36.9	26800	64100	
	247.15	3.0	9.0	26300	3.6	10.5	25500	5.9	16.0	24100	11.7	30.7	23200	56000	
279.64	2.7	9.6	31600	3.2	11.2	30700	5.2	16.8	28600	10.4	31.6	27000	64100		
332.31	2.3	7.0	27500	2.7	8.2	26700	4.4	12.3	24900	8.7	23.2	23600	56000		
RE 3514	202.33	3.7	19.1	44500	4.4	22.7	44000	7.2	33.8	40700	14.3	54.8	33000	96500	17 (H) 18 (F)
	209.95	3.6	18.5	44600	4.3	21.9	44100	6.9	32.9	41100	13.8	53.4	33400	96500	
	247.86	3.0	15.8	45000	3.6	18.7	44600	5.9	29.3	43200	11.7	47.6	35100	96500	
	291.01	2.6	12.1	40600	3.1	14.2	39500	5.0	21.2	36800	10.0	39.3	34000	79800	
	311.04	2.4	12.9	46300	2.9	15.1	45100	4.7	23.7	43900	9.3	40.6	37600	96500	
	350.48	2.1	10.4	41800	2.6	12.1	40600	4.1	18.1	37800	8.3	33.0	34400	79800	
	408.66	1.8	9.1	42800	2.2	10.6	41600	3.5	15.9	38700	7.1	28.7	34800	79800	
	447.37	1.7	8.4	43300	2.0	9.8	42200	3.2	14.7	39200	6.5	26.5	35300	79800	
	501.74	1.5	7.2	41800	1.8	8.6	41400	2.9	13.4	39900	5.8	24.1	35900	79800	
	570.55	1.3	6.7	43900	1.6	7.8	42700	2.5	11.8	40100	5.1	22.7	38500	92900	
	648.00	1.2	6.1	45800	1.4	7.2	44600	2.2	10.8	41500	4.5	19.4	37400	79800	
	703.80	1.1	5.7	46400	1.3	6.7	45200	2.1	10.0	42000	4.1	18.1	37800	79800	
	807.90	0.93	4.0	37100	1.1	4.7	36100	1.8	7.0	33600	3.6	12.6	30200	64100	
	878.34	0.85	4.7	48000	1.0	5.5	46700	1.7	8.3	43400	3.3	15.0	39100	79800	
	1045.29	0.72	3.9	46500	0.86	4.5	45300	1.4	6.8	42100	2.8	12.9	40200	79800	
	1140.94	0.66	2.8	36900	0.79	3.3	35900	1.3	5.1	34600	2.5	9.4	31900	64100	
	1304.53	0.57	3.2	48100	0.69	3.7	46800	1.1	5.6	43600	2.2	10.5	40900	79800	
	1413.55	0.53	2.5	40400	0.64	2.9	39300	1.0	4.3	36500	2.1	7.8	32900	64100	
	1613.32	0.46	2.1	38900	0.56	2.4	37900	0.90	3.7	35300	1.8	7.0	33600	64100	
	1779.51	0.42	1.7	35400	0.51	2.0	34400	0.81	3.0	32000	1.6	5.4	28900	56000	
2013.43	0.37	0.2	40300	0.45	2.0	39200	0.72	3.0	36400	1.4	5.7	34400	64100		
2392.62	0.31	0.1	37000	0.38	1.6	36000	0.61	2.4	33500	1.2	4.2	30200	56000		

	ie	n <sub>1</sub> = 750 RPM			n <sub>1</sub> = 900 RPM			n <sub>1</sub> = 1450 RPM			n <sub>1</sub> = 2900 RPM			T <sub>2max</sub> [Nm]	P <sub>t</sub> [kW]
		n <sub>2</sub> [RPM]	P <sub>1</sub> [kW]	T <sub>2</sub> [Nm]	n <sub>2</sub> [RPM]	P <sub>1</sub> [kW]	T <sub>2</sub> [Nm]	n <sub>2</sub> [RPM]	P <sub>1</sub> [kW]	T <sub>2</sub> [Nm]	n <sub>2</sub> [RPM]	P <sub>1</sub> [kW]	T <sub>2</sub> [Nm]		
<b>RA 3512</b>	<b>12.48</b>	60	<b>206</b>	30600	72	<b>234</b>	29000	116	<b>326</b>	25100	232	<b>530</b>	20400	88500	30 (H) 31 (F)
	<b>15.39</b>	48.7	<b>169</b>	31100	58	<b>197</b>	30100	94	<b>275</b>	26100	188	<b>446</b>	21200	79800	
	<b>17.67</b>	42.4	<b>118</b>	24900	51	<b>141</b>	24700	82	<b>220</b>	24000	164	<b>399</b>	21800	64100	
	<b>21.00</b>	35.7	<b>87</b>	21700	42.9	<b>103</b>	21500	69	<b>162</b>	20900	138	<b>311</b>	20100	56000	
<b>RA 3513</b>	<b>39.99</b>	18.8	<b>66</b>	30500	22.5	<b>74</b>	28800	36.3	<b>104</b>	25000	73	<b>169</b>	20300	96500	20 (H) 20 (F)
	<b>46.63</b>	16.1	<b>58</b>	31400	19.3	<b>66</b>	29700	31.1	<b>92</b>	25800	62	<b>149</b>	20900	92900	
	<b>49.33</b>	15.2	<b>58</b>	33200	18.2	<b>69</b>	32900	29.4	<b>104</b>	30800	59	<b>169</b>	25000	79800	
	<b>57.51</b>	13.0	<b>50</b>	33500	15.6	<b>60</b>	33200	25.2	<b>92</b>	31800	50	<b>149</b>	25800	79800	
	<b>63.80</b>	11.8	<b>46.5</b>	34500	14.1	<b>53</b>	32600	22.7	<b>74</b>	28300	45.5	<b>120</b>	23000	92900	
	<b>70.62</b>	10.6	<b>41.3</b>	33900	12.7	<b>49.1</b>	33600	20.5	<b>77</b>	32600	41.1	<b>126</b>	26800	79800	
	<b>78.70</b>	9.5	<b>37.3</b>	34100	11.4	<b>44.3</b>	33800	18.4	<b>69</b>	32900	36.8	<b>120</b>	28400	79800	
	<b>90.35</b>	8.3	<b>26.1</b>	27400	10.0	<b>30.9</b>	27100	16.0	<b>48.5</b>	26300	32.1	<b>93</b>	25300	64100	
	<b>96.63</b>	7.8	<b>30.7</b>	34500	9.3	<b>36.5</b>	34200	15.0	<b>57</b>	33200	30.0	<b>101</b>	29500	79800	
	<b>110.34</b>	6.8	<b>25.3</b>	32400	8.2	<b>30.0</b>	32100	13.1	<b>47.1</b>	31200	26.3	<b>90</b>	30000	79800	
	<b>126.66</b>	5.9	<b>19.0</b>	28000	7.1	<b>22.5</b>	27600	11.4	<b>35.3</b>	26900	22.9	<b>68</b>	25800	64100	
	<b>131.82</b>	5.7	<b>15.8</b>	24100	6.8	<b>18.7</b>	23900	11.0	<b>29.3</b>	23200	22.0	<b>56</b>	22300	56000	
	<b>149.14</b>	5.0	<b>16.6</b>	28700	6.0	<b>19.4</b>	28000	9.7	<b>30.2</b>	27100	19.4	<b>58</b>	26100	64100	
	<b>177.23</b>	4.2	<b>12.1</b>	25000	5.1	<b>14.2</b>	24300	8.2	<b>22.2</b>	23600	16.4	<b>43</b>	22700	56000	
<b>RA 3514</b>	<b>137.19</b>	5.5	<b>28.0</b>	43500	6.6	<b>32.2</b>	41700	10.6	<b>45.0</b>	36200	21.1	<b>73</b>	29400	96500	16 (H) 16 (F)
	<b>161.96</b>	4.6	<b>23.9</b>	43900	5.6	<b>28.4</b>	43500	9.0	<b>40.1</b>	38000	17.9	<b>65</b>	30900	96500	
	<b>196.99</b>	3.8	<b>19.9</b>	44400	4.6	<b>23.6</b>	44000	7.4	<b>33.4</b>	38600	14.7	<b>52.3</b>	30100	96500	
	<b>229.69</b>	3.3	<b>15.2</b>	39500	3.9	<b>18.0</b>	39100	6.3	<b>28.3</b>	38100	12.6	<b>50.1</b>	33800	92900	
	<b>250.71</b>	3.0	<b>14.0</b>	39700	3.6	<b>16.3</b>	38600	5.8	<b>24.5</b>	35900	11.6	<b>45.9</b>	33700	79800	
	<b>283.34</b>	2.6	<b>12.6</b>	40400	3.2	<b>14.7</b>	39300	5.1	<b>22.0</b>	36600	10.2	<b>40.9</b>	34000	79800	
	<b>317.56</b>	2.4	<b>9.0</b>	32200	2.8	<b>10.5</b>	31300	4.6	<b>15.7</b>	29200	9.1	<b>29.2</b>	27200	56000	
	<b>358.92</b>	2.1	<b>10.1</b>	41000	2.5	<b>12.0</b>	40600	4.0	<b>18.0</b>	37900	8.1	<b>32.7</b>	34400	79800	
	<b>395.58</b>	1.9	<b>9.3</b>	41500	2.3	<b>10.8</b>	40400	3.7	<b>16.9</b>	39300	7.3	<b>32.6</b>	37700	92900	
	<b>445.50</b>	1.7	<b>5.7</b>	28700	2.0	<b>6.6</b>	27900	3.3	<b>10.0</b>	26000	6.5	<b>18.3</b>	23900	56000	
	<b>504.73</b>	1.5	<b>7.3</b>	41800	1.8	<b>8.7</b>	41400	2.9	<b>13.5</b>	40000	5.7	<b>24.3</b>	36000	79800	
	<b>561.00</b>	1.3	<b>4.8</b>	30300	1.6	<b>5.7</b>	30000	2.6	<b>8.9</b>	29200	5.2	<b>17.1</b>	28100	56000	
	<b>633.86</b>	1.2	<b>4.8</b>	34800	1.4	<b>5.8</b>	34400	2.3	<b>8.7</b>	32400	4.6	<b>15.7</b>	29200	64100	
	<b>724.74</b>	1.0	<b>5.4</b>	44000	1.2	<b>6.3</b>	42800	2.0	<b>9.7</b>	41100	4.0	<b>17.9</b>	38000	79800	
	<b>795.43</b>	0.94	<b>3.9</b>	35200	1.1	<b>4.6</b>	34900	1.8	<b>7.2</b>	33500	3.6	<b>12.9</b>	30200	64100	
	<b>924.69</b>	0.81	<b>3.4</b>	35800	1.0	<b>4.0</b>	35200	1.6	<b>6.3</b>	34200	3.1	<b>11.4</b>	30900	64100	
	<b>988.62</b>	0.76	<b>2.9</b>	32400	0.91	<b>3.4</b>	31500	1.5	<b>5.1</b>	29300	2.9	<b>9.1</b>	26400	56000	
	<b>1118.57</b>	0.67	<b>2.9</b>	36800	0.80	<b>3.4</b>	35800	1.3	<b>5.3</b>	34600	2.6	<b>9.7</b>	31800	64100	

	ie	n <sub>1</sub> = 750 RPM			n <sub>1</sub> = 900 RPM			n <sub>1</sub> = 1450 RPM			n <sub>1</sub> = 2900 RPM			T <sub>2max</sub> [Nm]	P <sub>t</sub> [kW]
		n <sub>2</sub> [RPM]	P <sub>1</sub> [kW]	T <sub>2</sub> [Nm]	n <sub>2</sub> [RPM]	P <sub>1</sub> [kW]	T <sub>2</sub> [Nm]	n <sub>2</sub> [RPM]	P <sub>1</sub> [kW]	T <sub>2</sub> [Nm]	n <sub>2</sub> [RPM]	P <sub>1</sub> [kW]	T <sub>2</sub> [Nm]		
<b>RE 4801</b>	<b>3.84</b>	195	<b>601</b>	28700	234	<b>683</b>	27100	378	<b>953</b>	23500	—	—	—	111000	53 (H)
	<b>5.18</b>	145	<b>471</b>	30200	174	<b>535</b>	28600	280	<b>746</b>	24800	—	—	—	93500	54 (F)
<b>RE 4802</b>	<b>13.17</b>	57	<b>227</b>	36200	68	<b>258</b>	34300	110	<b>361</b>	29700	—	—	—	111000	34 (H) 34 (F)
	<b>15.71</b>	47.7	<b>198</b>	37600	57	<b>225</b>	35600	92	<b>314</b>	30900	—	—	—	111000	
	<b>17.75</b>	42.3	<b>167</b>	35900	51	<b>198</b>	35500	82	<b>311</b>	34600	—	—	—	93500	
	<b>20.16</b>	37.2	<b>162</b>	39400	44.6	<b>184</b>	37300	72	<b>256</b>	32400	—	—	—	111000	
	<b>21.18</b>	35.4	<b>141</b>	36300	42.5	<b>168</b>	35900	68	<b>263</b>	34900	—	—	—	93500	
	<b>23.93</b>	31.3	<b>116</b>	33700	37.6	<b>138</b>	33400	61	<b>217</b>	32500	—	—	—	92900	
	<b>27.18</b>	27.6	<b>112</b>	36800	33.1	<b>133</b>	36400	53	<b>208</b>	35400	—	—	—	93500	
	<b>32.25</b>	23.3	<b>95</b>	37100	27.9	<b>113</b>	36800	45.0	<b>177</b>	35800	—	—	—	93500	
<b>RE 4803</b>	<b>47.40</b>	15.8	<b>80</b>	44700	19.0	<b>91</b>	42400	30.6	<b>127</b>	36700	61	<b>206</b>	29800	111000	24 (H) 25 (F)
	<b>56.55</b>	13.3	<b>79</b>	52700	15.9	<b>91</b>	50500	25.6	<b>127</b>	43800	51	<b>206</b>	35600	111000	
	<b>66.76</b>	11.2	<b>67</b>	53200	13.5	<b>80</b>	52300	21.7	<b>111</b>	45300	43.4	<b>181</b>	36800	111000	
	<b>72.58</b>	10.3	<b>53</b>	45700	12.4	<b>63</b>	45300	20.0	<b>99</b>	44000	40.0	<b>174</b>	38600	111000	
	<b>83.78</b>	9.0	<b>54</b>	53900	10.7	<b>65</b>	53300	17.3	<b>92</b>	47200	34.6	<b>150</b>	38400	111000	
	<b>90.00</b>	8.3	<b>37.1</b>	39400	10.0	<b>44.0</b>	39000	16.1	<b>69</b>	37900	32.2	<b>133</b>	36400	93500	
	<b>101.69</b>	7.4	<b>30.5</b>	36600	8.9	<b>36.3</b>	36300	14.3	<b>57</b>	35300	28.5	<b>109</b>	33900	92900	
	<b>112.94</b>	6.6	<b>29.9</b>	39900	8.0	<b>35.5</b>	39500	12.8	<b>56</b>	38400	25.7	<b>107</b>	36900	93500	
	<b>124.99</b>	6.0	<b>32.0</b>	47200	7.2	<b>38.0</b>	46700	11.6	<b>60</b>	45400	23.2	<b>114</b>	43700	111000	
	<b>144.94</b>	5.2	<b>23.7</b>	40500	6.2	<b>28.1</b>	40000	10.0	<b>44.0</b>	39000	20.0	<b>85</b>	37500	93500	
	<b>158.82</b>	4.7	<b>21.8</b>	40900	5.7	<b>25.8</b>	40300	9.1	<b>40.4</b>	39200	18.3	<b>78</b>	37700	93500	
	<b>172.02</b>	4.4	<b>20.4</b>	41400	5.2	<b>23.9</b>	40400	8.4	<b>37.5</b>	39400	16.9	<b>72</b>	37800	93500	
	<b>199.97</b>	3.8	<b>17.9</b>	42300	4.5	<b>20.9</b>	41200	7.3	<b>32.5</b>	39700	14.5	<b>63</b>	38200	93500	
	<b>241.90</b>	3.1	<b>15.3</b>	43600	3.7	<b>17.8</b>	42400	6.0	<b>27.2</b>	40100	12.0	<b>52</b>	38600	93500	
<b>RE 4804</b>	<b>164.94</b>	4.5	<b>27.9</b>	54300	5.5	<b>32.5</b>	51400	8.8	<b>45.4</b>	44500	17.6	<b>74</b>	36200	111000	19 (H) 19 (F)
	<b>196.80</b>	3.8	<b>25.9</b>	60100	4.6	<b>31.0</b>	58500	7.4	<b>45.4</b>	53100	14.7	<b>74</b>	43200	111000	
	<b>232.34</b>	3.2	<b>22.5</b>	61700	3.9	<b>26.9</b>	60000	6.2	<b>40.4</b>	55800	12.5	<b>74</b>	50900	111000	
	<b>252.56</b>	3.0	<b>16.5</b>	49100	3.6	<b>20.1</b>	48600	5.7	<b>31.5</b>	47300	11.5	<b>60</b>	45400	111000	
	<b>284.62</b>	2.6	<b>18.9</b>	63600	3.2	<b>22.7</b>	61900	5.1	<b>34.0</b>	57600	10.2	<b>63</b>	53400	111000	
	<b>322.81</b>	2.3	<b>14.1</b>	53900	2.8	<b>17.2</b>	53300	4.5	<b>27.0</b>	51900	9.0	<b>49.4</b>	47400	111000	
	<b>357.18</b>	2.1	<b>14.0</b>	58900	2.5	<b>17.0</b>	58300	4.1	<b>26.7</b>	56800	8.1	<b>50.9</b>	54200	111000	
	<b>401.94</b>	1.9	<b>9.9</b>	47100	2.2	<b>11.9</b>	45800	3.6	<b>17.8</b>	42600	7.2	<b>33.2</b>	39700	93500	
	<b>456.90</b>	1.6	<b>8.9</b>	48000	2.0	<b>10.7</b>	46700	3.2	<b>16.0</b>	43400	6.3	<b>29.4</b>	40000	93500	
	<b>504.40</b>	1.5	<b>8.2</b>	48700	1.8	<b>9.8</b>	47400	2.9	<b>14.7</b>	44100	5.7	<b>26.8</b>	40200	93500	
	<b>564.43</b>	1.3	<b>7.4</b>	49500	1.6	<b>8.9</b>	48200	2.6	<b>13.3</b>	44800	5.1	<b>24.1</b>	40500	93500	
	<b>634.83</b>	1.2	<b>6.7</b>	50400	1.4	<b>8.1</b>	49100	2.3	<b>12.1</b>	45600	4.6	<b>21.8</b>	41100	93500	
	<b>709.31</b>	1.1	<b>6.1</b>	51300	1.3	<b>7.3</b>	49900	2.0	<b>11.0</b>	46400	4.1	<b>19.8</b>	41800	93500	
	<b>792.27</b>	0.95	<b>5.6</b>	52100	1.1	<b>6.7</b>	50700	1.8	<b>10.0</b>	47200	3.7	<b>18.0</b>	42500	93500	
	<b>899.94</b>	0.83	<b>5.3</b>	56500	1.0	<b>6.4</b>	54900	1.6	<b>9.5</b>	51100	3.2	<b>18.2</b>	48900	111000	
	<b>992.41</b>	0.76	<b>4.6</b>	53900	0.91	<b>5.5</b>	52500	1.5	<b>8.3</b>	48800	2.9	<b>14.9</b>	44000	93500	
	<b>1143.53</b>	0.66	<b>4.0</b>	54200	0.79	<b>4.9</b>	53600	1.3	<b>7.3</b>	49900	2.5	<b>13.2</b>	44900	93500	
	<b>1238.53</b>	0.61	<b>3.8</b>	55800	0.73	<b>4.6</b>	54300	1.2	<b>6.8</b>	50500	2.3	<b>12.3</b>	45500	93500	
	<b>1439.79</b>	0.52	<b>3.4</b>	57100	0.63	<b>4.0</b>	55500	1.0	<b>6.0</b>	51700	2.0	<b>10.9</b>	46500	93500	
	<b>1741.68</b>	0.43	<b>2.9</b>	58700	0.52	<b>3.4</b>	57100	0.83	<b>5.1</b>	53200	1.7	<b>9.2</b>	47900	93500	

	ie	n <sub>1</sub> = 750 RPM			n <sub>1</sub> = 900 RPM			n <sub>1</sub> = 1450 RPM			n <sub>1</sub> = 2900 RPM			T <sub>2max</sub> [Nm]	P <sub>t</sub> [kW]
		n <sub>2</sub> [RPM]	P <sub>1</sub> [kW]	T <sub>2</sub> [Nm]	n <sub>2</sub> [RPM]	P <sub>1</sub> [kW]	T <sub>2</sub> [Nm]	n <sub>2</sub> [RPM]	P <sub>1</sub> [kW]	T <sub>2</sub> [Nm]	n <sub>2</sub> [RPM]	P <sub>1</sub> [kW]	T <sub>2</sub> [Nm]		
<b>RA 4802</b>	<b>12.48</b>	60	<b>233</b>	34600	72	<b>273</b>	33800	116	<b>381</b>	29300	232	<b>619</b>	23800	88500	30 (H)
	<b>16.82</b>	44.6	<b>178</b>	35800	53	<b>212</b>	35400	86	<b>332</b>	34500	172	<b>553</b>	28700	93500	31 (F)
<b>RA 4803</b>	<b>40.44</b>	18.5	<b>108</b>	50800	22.3	<b>123</b>	48100	35.9	<b>171</b>	41600	72	<b>278</b>	33800	111000	24 (H) 18 (F)
	<b>48.25</b>	15.5	<b>93</b>	52200	18.7	<b>107</b>	49900	30.1	<b>149</b>	43200	60	<b>242</b>	35100	111000	
	<b>54.51</b>	13.8	<b>60</b>	38300	16.5	<b>72</b>	37900	26.6	<b>112</b>	36900	53	<b>216</b>	35400	93500	
	<b>61.92</b>	12.1	<b>63</b>	45300	14.5	<b>75</b>	44800	23.4	<b>117</b>	43600	46.8	<b>198</b>	36800	111000	
	<b>73.31</b>	10.2	<b>55</b>	47100	12.3	<b>66</b>	46600	19.8	<b>103</b>	45300	39.6	<b>181</b>	39800	111000	
	<b>94.08</b>	8.0	<b>42.4</b>	46400	9.6	<b>50</b>	45900	15.4	<b>79</b>	44700	30.8	<b>148</b>	41700	111000	
	<b>99.06</b>	7.6	<b>34.4</b>	39600	9.1	<b>40.8</b>	39200	14.6	<b>64</b>	38100	29.3	<b>123</b>	36700	93500	
	<b>111.66</b>	6.7	<b>28.4</b>	36800	8.1	<b>33.7</b>	36500	13.0	<b>53</b>	35500	26.0	<b>102</b>	34100	92900	
	<b>126.82</b>	5.9	<b>27.2</b>	40200	7.1	<b>32.4</b>	39700	11.4	<b>51</b>	38700	22.9	<b>98</b>	37200	93500	
	<b>150.52</b>	5.0	<b>23.2</b>	40600	6.0	<b>27.5</b>	40100	9.6	<b>43.2</b>	39100	19.3	<b>83</b>	37500	93500	
<b>RA 4804</b>	<b>132.03</b>	5.7	<b>28.5</b>	42600	6.8	<b>32.4</b>	40400	11.0	<b>45.2</b>	35000	22.0	<b>73</b>	28400	111000	17 (H) 15 (F)
	<b>157.54</b>	4.8	<b>28.5</b>	50900	5.7	<b>32.4</b>	48200	9.2	<b>45.2</b>	41700	18.4	<b>73</b>	33900	111000	
	<b>177.99</b>	4.2	<b>20.6</b>	41600	5.1	<b>24.1</b>	40500	8.1	<b>37.8</b>	39400	16.3	<b>73</b>	37900	93500	
	<b>202.18</b>	3.7	<b>21.2</b>	48500	4.5	<b>25.1</b>	48000	7.2	<b>39.4</b>	46700	14.3	<b>73</b>	43500	111000	
	<b>223.82</b>	3.4	<b>21.1</b>	53500	4.0	<b>24.0</b>	50600	6.5	<b>33.4</b>	43900	13.0	<b>54.3</b>	35600	111000	
	<b>250.71</b>	3.0	<b>15.4</b>	43800	3.6	<b>18.0</b>	42600	5.8	<b>27.4</b>	40200	11.6	<b>53</b>	38600	93500	
	<b>280.87</b>	2.7	<b>15.5</b>	49200	3.2	<b>18.4</b>	48700	5.2	<b>28.8</b>	47400	10.3	<b>54.3</b>	44700	111000	
	<b>314.62</b>	2.4	<b>12.7</b>	45300	2.9	<b>14.8</b>	44100	4.6	<b>22.3</b>	41000	9.2	<b>42.5</b>	39200	93500	
	<b>348.19</b>	2.2	<b>12.7</b>	50000	2.6	<b>15.1</b>	49500	4.2	<b>23.6</b>	48200	8.3	<b>45.4</b>	46300	111000	
	<b>403.76</b>	1.9	<b>10.3</b>	47100	2.2	<b>12.0</b>	45800	3.6	<b>18.0</b>	42600	7.2	<b>33.6</b>	39700	93500	
	<b>442.44</b>	1.7	<b>9.5</b>	47700	2.0	<b>11.1</b>	46400	3.3	<b>16.7</b>	43200	6.6	<b>30.8</b>	39900	93500	
	<b>499.97</b>	1.5	<b>9.1</b>	51700	1.8	<b>10.7</b>	50500	2.9	<b>16.8</b>	49200	5.8	<b>32.3</b>	47300	111000	
	<b>567.79</b>	1.3	<b>7.7</b>	49600	1.6	<b>9.0</b>	48200	2.6	<b>13.5</b>	44900	5.1	<b>24.3</b>	40500	93500	
	<b>635.29</b>	1.2	<b>7.0</b>	50400	1.4	<b>8.2</b>	49100	2.3	<b>12.3</b>	45600	4.6	<b>22.1</b>	41100	93500	
	<b>688.07</b>	1.1	<b>6.5</b>	51000	1.3	<b>7.6</b>	49700	2.1	<b>11.5</b>	46200	4.2	<b>20.6</b>	41600	93500	
	<b>799.88</b>	0.94	<b>5.8</b>	52200	1.1	<b>6.7</b>	50800	1.8	<b>10.1</b>	47300	3.6	<b>18.2</b>	42600	93500	
<b>967.60</b>	0.78	<b>4.9</b>	53700	0.93	<b>5.7</b>	52300	1.5	<b>8.6</b>	48600	3.0	<b>15.4</b>	43800	93500		

		n <sub>1</sub> = 750 RPM			n <sub>1</sub> = 900 RPM			n <sub>1</sub> = 1450 RPM			n <sub>1</sub> = 2900 RPM			T <sub>2max</sub> [Nm]	P <sub>t</sub> [kW]
		n <sub>2</sub> [RPM]	P <sub>1</sub> [kW]	T <sub>2</sub> [Nm]	n <sub>2</sub> [RPM]	P <sub>1</sub> [kW]	T <sub>2</sub> [Nm]	n <sub>2</sub> [RPM]	P <sub>1</sub> [kW]	T <sub>2</sub> [Nm]	n <sub>2</sub> [RPM]	P <sub>1</sub> [kW]	T <sub>2</sub> [Nm]		
<b>RE 6001</b>	<b>4.14</b>	181	<b>576</b>	29600	217	<b>654</b>	28100	350	<b>910</b>	24300	—	—	—	136000	70 (H) 63 (F)
	<b>5.40</b>	139	<b>467</b>	31300	167	<b>530</b>	29600	269	<b>740</b>	25700	—	—	—	112000	
	<b>6.50</b>	115	<b>383</b>	30900	138	<b>452</b>	30400	223	<b>630</b>	26400	—	—	—	85300	
<b>RE 6002</b>	L <b>14.20</b>	53	<b>227</b>	39100	63	<b>258</b>	37000	102	<b>361</b>	32100	—	—	—	114000	40 (H) 36 (F)
	<b>15.88</b>	47.2	<b>231</b>	44400	57	<b>262</b>	42000	91	<b>366</b>	36400	—	—	—	135000	
	L <b>16.95</b>	44.3	<b>198</b>	40600	53	<b>225</b>	38400	86	<b>314</b>	33300	—	—	—	114000	
	<b>20.70</b>	36.2	<b>175</b>	43900	43.5	<b>212</b>	43400	70	<b>296</b>	38400	—	—	—	112000	
	<b>21.75</b>	34.5	<b>185</b>	48700	41.4	<b>210</b>	46200	67	<b>294</b>	40000	—	—	—	135000	
	L <b>22.09</b>	34.0	<b>165</b>	44100	40.7	<b>196</b>	43600	66	<b>283</b>	39200	—	—	—	85300	
	L <b>25.81</b>	29.1	<b>116</b>	36400	34.9	<b>138</b>	36000	56	<b>217</b>	35000	—	—	—	114000	
	L <b>28.35</b>	26.5	<b>130</b>	44700	31.7	<b>155</b>	44200	51	<b>238</b>	42200	—	—	—	112000	
	L <b>33.65</b>	22.3	<b>111</b>	45100	26.7	<b>132</b>	44700	43.1	<b>206</b>	43500	—	—	—	112000	
L <b>40.50</b>	18.5	<b>70</b>	34300	22.2	<b>83</b>	34000	35.8	<b>130</b>	33100	—	—	—	85300		
<b>RE 6003</b>	L <b>51.13</b>	14.7	<b>80</b>	48300	17.6	<b>91</b>	45700	28.4	<b>127</b>	39600	57	<b>206</b>	32200	114000	28 (H) 28 (F)
	<b>63.52</b>	11.8	<b>77</b>	57700	14.2	<b>102</b>	57100	22.8	<b>142</b>	55200	45.7	<b>231</b>	44800	135000	
	L <b>72.03</b>	10.4	<b>68</b>	58200	12.5	<b>80</b>	56400	20.1	<b>111</b>	48900	40.3	<b>181</b>	39700	114000	
	L <b>79.53</b>	9.4	<b>51</b>	47400	11.3	<b>60</b>	46900	18.2	<b>94</b>	45600	36.5	<b>181</b>	43900	112000	
	<b>98.86</b>	7.6	<b>51</b>	60100	9.1	<b>75</b>	58600	14.7	<b>104</b>	57000	29.3	<b>169</b>	51200	135000	
	L <b>114.79</b>	6.5	<b>35.7</b>	48400	7.8	<b>42.4</b>	47900	12.6	<b>67</b>	46600	25.3	<b>128</b>	44800	112000	
	L <b>120.49</b>	6.2	<b>34.2</b>	48600	7.5	<b>40.5</b>	48000	12.0	<b>64</b>	46700	24.1	<b>122</b>	44900	112000	
	L <b>141.82</b>	5.3	<b>22.0</b>	36900	6.3	<b>26.2</b>	36500	10.2	<b>41.0</b>	35500	20.4	<b>79</b>	34100	85300	
	L <b>160.04</b>	4.7	<b>21.4</b>	40400	5.6	<b>25.4</b>	40000	9.1	<b>39.8</b>	38900	18.1	<b>77</b>	37400	100000	
	L <b>175.77</b>	4.3	<b>24.8</b>	51500	5.1	<b>29.0</b>	50100	8.2	<b>44.5</b>	47800	16.5	<b>86</b>	45900	112000	
	L <b>199.43</b>	3.8	<b>16.4</b>	38700	4.5	<b>19.2</b>	37600	7.3	<b>29.7</b>	36200	14.5	<b>57</b>	34800	85300	
	L <b>216.00</b>	3.5	<b>15.4</b>	39100	4.2	<b>17.9</b>	38100	6.7	<b>27.6</b>	36400	13.4	<b>53</b>	35000	85300	
L <b>251.10</b>	3.0	<b>13.5</b>	40000	3.6	<b>15.8</b>	38900	5.8	<b>23.9</b>	36700	11.5	<b>46</b>	35300	85300		
<b>RE 6004</b>	L <b>177.95</b>	4.2	<b>28.6</b>	58500	5.1	<b>32.5</b>	55400	8.1	<b>45.4</b>	48000	16.3	<b>74</b>	39000	114000	22 (H) 21 (F)
	L <b>212.33</b>	3.5	<b>27.6</b>	67400	4.2	<b>32.2</b>	65600	6.8	<b>45.4</b>	57300	13.7	<b>74</b>	46600	114000	
	<b>228.69</b>	3.3	<b>25.9</b>	68200	3.9	<b>42.6</b>	66300	6.3	<b>59</b>	61700	12.7	<b>97</b>	57500	135000	
	L <b>250.66</b>	3.0	<b>23.8</b>	68700	3.6	<b>28.0</b>	67300	5.8	<b>42.0</b>	62600	11.6	<b>74</b>	55000	114000	
	L <b>284.15</b>	2.6	<b>16.9</b>	55300	3.2	<b>19.8</b>	53800	5.1	<b>29.6</b>	50100	10.2	<b>56</b>	47200	112000	
	<b>313.20</b>	2.4	<b>19.3</b>	69400	2.9	<b>34.2</b>	68700	4.6	<b>47.7</b>	64700	9.3	<b>78</b>	58500	135000	
	<b>355.91</b>	2.1	<b>17.1</b>	69900	2.5	<b>31.3</b>	69200	4.1	<b>43.6</b>	66000	8.1	<b>71</b>	59400	135000	
	<b>393.85</b>	1.9	<b>16.3</b>	74000	2.3	<b>29.1</b>	72000	3.7	<b>40.7</b>	67000	7.4	<b>66</b>	60300	135000	
	<b>447.55</b>	1.7	<b>14.7</b>	75500	2.0	<b>26.6</b>	73400	3.2	<b>37.2</b>	68300	6.5	<b>60</b>	61500	135000	
	L <b>502.28</b>	1.5	<b>10.4</b>	60300	1.8	<b>12.2</b>	58700	2.9	<b>18.3</b>	54600	5.8	<b>32.9</b>	49200	112000	
	L <b>569.67</b>	1.3	<b>9.4</b>	61500	1.6	<b>10.9</b>	59800	2.5	<b>16.4</b>	55600	5.1	<b>29.6</b>	50100	112000	
	<b>621.00</b>	1.2	<b>8.7</b>	62300	1.4	<b>20.6</b>	60600	2.3	<b>28.8</b>	56400	4.7	<b>46.8</b>	50800	112000	
	<b>703.08</b>	1.1	<b>7.8</b>	63500	1.3	<b>18.9</b>	61700	2.1	<b>26.4</b>	57400	4.1	<b>42.9</b>	51700	112000	
	L <b>790.17</b>	0.95	<b>7.1</b>	64600	1.1	<b>8.3</b>	62800	1.8	<b>12.4</b>	58500	3.7	<b>22.4</b>	52600	112000	
	L <b>906.45</b>	0.83	<b>6.3</b>	66000	1.0	<b>7.4</b>	64200	1.6	<b>11.1</b>	59700	3.2	<b>19.9</b>	53800	112000	
	L <b>986.14</b>	0.76	<b>5.9</b>	66800	0.91	<b>6.9</b>	65000	1.5	<b>10.3</b>	60500	2.9	<b>18.6</b>	54400	112000	
	L <b>1088.64</b>	0.69	<b>5.4</b>	67800	0.83	<b>6.3</b>	66000	1.3	<b>9.5</b>	61400	2.7	<b>17.1</b>	55300	112000	
	L <b>1265.54</b>	0.59	<b>4.8</b>	69400	0.71	<b>5.6</b>	67500	1.1	<b>8.3</b>	62800	2.3	<b>15.0</b>	56500	112000	
	L <b>1435.91</b>	0.52	<b>3.2</b>	52100	0.63	<b>3.7</b>	50700	1.0	<b>5.5</b>	47200	2.0	<b>9.9</b>	42500	85300	

		n <sub>1</sub> = 750 RPM			n <sub>1</sub> = 900 RPM			n <sub>1</sub> = 1450 RPM			n <sub>1</sub> = 2900 RPM			T <sub>2max</sub> [Nm]	P <sub>t</sub> [kW]
ie		n <sub>2</sub> [RPM]	P <sub>1</sub> [kW]	T <sub>2</sub> [Nm]	n <sub>2</sub> [RPM]	P <sub>1</sub> [kW]	T <sub>2</sub> [Nm]	n <sub>2</sub> [RPM]	P <sub>1</sub> [kW]	T <sub>2</sub> [Nm]	n <sub>2</sub> [RPM]	P <sub>1</sub> [kW]	T <sub>2</sub> [Nm]		
<b>RA 6002</b>		56	<b>233</b>	37300	67	<b>273</b>	36500	108	<b>381</b>	31600	215	<b>619</b>	25700	95500	36 (H) 34 (F)
		42.7	<b>208</b>	43500	51	<b>242</b>	42200	83	<b>338</b>	36600	165	<b>549</b>	29700	112000	
		35.5	<b>131</b>	33100	42.6	<b>156</b>	32700	69	<b>245</b>	31900	137	<b>469</b>	30500	85300	
<b>RA 6003</b>	L	17.2	<b>108</b>	54800	20.6	<b>123</b>	51800	33.2	<b>171</b>	44900	66	<b>278</b>	36500	114000	27 (H) 25 (F)
	L	14.4	<b>94</b>	56900	17.3	<b>107</b>	53800	27.9	<b>149</b>	46700	56	<b>242</b>	37900	114000	
	L	13.2	<b>70</b>	46500	15.8	<b>84</b>	46000	25.5	<b>131</b>	44800	51	<b>247</b>	42300	112000	
		11.2	<b>75</b>	57900	13.5	<b>89</b>	57300	21.7	<b>139</b>	55800	43.4	<b>227</b>	45500	135000	
		10.1	<b>55</b>	47600	12.1	<b>66</b>	47100	19.6	<b>103</b>	45800	39.1	<b>196</b>	43600	135000	
	L	9.5	<b>55</b>	50800	11.4	<b>66</b>	50200	18.3	<b>103</b>	48900	36.7	<b>181</b>	43000	114000	
	L	8.6	<b>47.1</b>	47600	10.3	<b>56</b>	47200	16.7	<b>88</b>	45900	33.3	<b>169</b>	44100	112000	
		7.4	<b>51</b>	60300	8.9	<b>60</b>	58700	14.3	<b>94</b>	57100	28.6	<b>169</b>	51600	135000	
		6.5	<b>27.0</b>	36500	7.7	<b>32.1</b>	36100	12.5	<b>50</b>	35100	24.9	<b>97</b>	33800	85300	
	L	5.7	<b>32.1</b>	49300	6.8	<b>37.7</b>	48300	11.0	<b>59</b>	47000	21.9	<b>114</b>	45200	112000	
L	4.8	<b>27.7</b>	50600	5.7	<b>32.4</b>	49200	9.2	<b>50</b>	47500	18.5	<b>97</b>	45600	112000		
<b>RA 6004</b>	L	5.3	<b>28.5</b>	46000	6.3	<b>32.4</b>	43500	10.2	<b>45.2</b>	37700	20.4	<b>73</b>	30600	114000	20 (H) 18 (F)
	L	4.5	<b>28.5</b>	54300	5.4	<b>32.4</b>	51400	8.6	<b>45.2</b>	44500	17.2	<b>73</b>	36200	114000	
		4.2	<b>28.5</b>	57100	5.1	<b>32.4</b>	54100	8.2	<b>45.2</b>	46900	16.4	<b>73</b>	38100	135000	
	L	3.7	<b>28.5</b>	64800	4.5	<b>32.4</b>	61300	7.2	<b>45.2</b>	53200	14.5	<b>73</b>	43200	114000	
	L	3.4	<b>21.2</b>	53300	4.1	<b>24.8</b>	51800	6.5	<b>37.3</b>	48400	13.1	<b>72</b>	46500	112000	
	L	3.0	<b>21.8</b>	62100	3.6	<b>25.8</b>	61400	5.8	<b>40.5</b>	59800	11.5	<b>73</b>	54200	114000	
	L	2.6	<b>17.2</b>	55300	3.2	<b>20.1</b>	53800	5.1	<b>30.1</b>	50100	10.2	<b>57</b>	47200	112000	
	L	2.4	<b>15.8</b>	56200	2.9	<b>18.4</b>	54700	4.6	<b>27.6</b>	50900	9.2	<b>51.5</b>	47500	112000	
		2.2	<b>17.7</b>	69900	2.6	<b>21.0</b>	69100	4.2	<b>32.3</b>	65800	8.3	<b>54.3</b>	55400	135000	
		1.9	<b>15.7</b>	70400	2.3	<b>18.7</b>	69600	3.7	<b>28.9</b>	67100	7.3	<b>52.1</b>	60400	135000	
		1.7	<b>11.6</b>	59400	2.0	<b>10.0</b>	42600	3.2	<b>14.9</b>	39600	6.4	<b>36.5</b>	48500	85300	
		1.5	<b>10.4</b>	60600	1.7	<b>12.1</b>	58900	2.8	<b>18.1</b>	54800	5.6	<b>32.7</b>	49400	112000	
	L	1.4	<b>9.8</b>	61100	1.6	<b>11.5</b>	59500	2.6	<b>17.2</b>	55300	5.3	<b>31.0</b>	49800	112000	
	L	1.2	<b>6.1</b>	44100	1.4	<b>7.2</b>	43300	2.3	<b>11.2</b>	42100	4.5	<b>21.6</b>	40500	114000	
	L	1.1	<b>8.0</b>	63500	1.3	<b>9.3</b>	61700	2.1	<b>13.9</b>	57400	4.1	<b>25.1</b>	51700	112000	
	L	0.94	<b>5.3</b>	47700	1.1	<b>6.2</b>	46400	1.8	<b>9.2</b>	43200	3.6	<b>16.6</b>	38900	85300	
L	0.74	<b>5.2</b>	59200	0.89	<b>6.0</b>	57500	1.4	<b>9.4</b>	55500	2.9	<b>18.0</b>	53300	112000		

		n <sub>1</sub> = 750 RPM			n <sub>1</sub> = 900 RPM			n <sub>1</sub> = 1450 RPM			n <sub>1</sub> = 2900 RPM			T <sub>2max</sub> [Nm]	P <sub>t</sub> [kW]	
		ie	n <sub>2</sub> [RPM]	P <sub>1</sub> [kW]	T <sub>2</sub> [Nm]	n <sub>2</sub> [RPM]	P <sub>1</sub> [kW]	T <sub>2</sub> [Nm]	n <sub>2</sub> [RPM]	P <sub>1</sub> [kW]	T <sub>2</sub> [Nm]	n <sub>2</sub> [RPM]	P <sub>1</sub> [kW]			T <sub>2</sub> [Nm]
<b>RE 8001</b>		<b>4.00</b>	188	<b>789</b>	39200	225	<b>897</b>	37100	363	<b>1252</b>	32200	—	—	—	198000	77
		<b>4.67</b>	161	<b>696</b>	40300	193	<b>790</b>	38200	311	<b>1104</b>	33100	—	—	—	175000	(H-F)
<b>RE 8002</b>	L	<b>14.50</b>	52	<b>329</b>	57700	62	<b>373</b>	54600	100	<b>521</b>	47300	—	—	—	198000	45 (H-F)
	L	<b>16.00</b>	46.9	<b>302</b>	58500	56	<b>343</b>	55400	91	<b>479</b>	48000	—	—	—	198000	
		<b>18.82</b>	39.8	<b>274</b>	62400	47.8	<b>311</b>	59100	77	<b>434</b>	51200	—	—	—	198000	
	L	<b>20.80</b>	36.1	<b>244</b>	61400	43.3	<b>277</b>	58100	70	<b>387</b>	50300	—	—	—	198000	
		<b>21.96</b>	34.2	<b>241</b>	64200	41.0	<b>274</b>	60700	66	<b>383</b>	52600	—	—	—	175000	
	L	<b>24.27</b>	30.9	<b>225</b>	66100	37.1	<b>256</b>	62600	60	<b>357</b>	54200	—	—	—	175000	
	L	<b>29.17</b>	25.7	<b>189</b>	66600	30.9	<b>224</b>	65900	49.7	<b>314</b>	57300	—	—	—	175000	
<b>RE 8003</b>	L	<b>51.66</b>	14.5	<b>100</b>	60800	17.4	<b>113</b>	57600	28.1	<b>158</b>	49900	—	—	—	198000	33 (H-F)
	L	<b>57.00</b>	13.2	<b>100</b>	67100	15.8	<b>113</b>	63500	25.4	<b>158</b>	55100	—	—	—	198000	
	L	<b>66.46</b>	11.3	<b>88</b>	69200	13.5	<b>100</b>	65500	21.8	<b>140</b>	56700	—	—	—	198000	
	L	<b>70.27</b>	10.7	<b>87</b>	72500	12.8	<b>100</b>	69200	20.6	<b>140</b>	60000	—	—	—	175000	
		<b>78.19</b>	9.6	<b>92</b>	85200	11.5	<b>110</b>	84300	18.5	<b>164</b>	78500	—	—	—	198000	
		<b>93.18</b>	8.0	<b>78</b>	86000	9.7	<b>93</b>	85100	15.6	<b>145</b>	82700	—	—	—	198000	
	L	<b>100.80</b>	7.4	<b>62</b>	74000	8.9	<b>74</b>	73200	14.4	<b>116</b>	71200	—	—	—	175000	
		<b>112.00</b>	6.7	<b>56</b>	74400	8.0	<b>67</b>	73700	12.9	<b>105</b>	71700	—	—	—	175000	
		<b>129.08</b>	5.8	<b>58</b>	89100	7.0	<b>68</b>	86700	11.2	<b>107</b>	84400	—	—	—	198000	
	L	<b>141.32</b>	5.3	<b>45.5</b>	75900	6.4	<b>54</b>	74600	10.3	<b>84</b>	72600	—	—	—	175000	
	L	<b>166.40</b>	4.5	<b>39.6</b>	77800	5.4	<b>46.3</b>	75700	8.7	<b>72</b>	73300	—	—	—	175000	
<b>RE 8004</b>	L	<b>185.96</b>	4.0	<b>41.7</b>	89300	4.8	<b>47.4</b>	84600	7.8	<b>66</b>	73300	15.6	<b>108</b>	59500	198000	26 (H-F)
	L	<b>205.20</b>	3.7	<b>40.5</b>	95600	4.4	<b>47.3</b>	93000	7.1	<b>66</b>	80900	14.1	<b>108</b>	65700	198000	
	L	<b>219.54</b>	3.4	<b>37.2</b>	93900	4.1	<b>42.2</b>	88900	6.6	<b>59</b>	77000	13.2	<b>96</b>	62600	198000	
	L	<b>255.98</b>	2.9	<b>32.2</b>	95000	3.5	<b>37.3</b>	91600	5.7	<b>52</b>	79400	11.3	<b>85</b>	64500	198000	
	L	<b>282.46</b>	2.7	<b>30.9</b>	100000	3.2	<b>36.0</b>	97600	5.1	<b>52</b>	87600	10.3	<b>85</b>	71100	198000	
	L	<b>321.23</b>	2.3	<b>26.3</b>	97300	2.8	<b>30.9</b>	95200	4.5	<b>44.4</b>	85000	9.0	<b>72</b>	69000	198000	
	L	<b>354.46</b>	2.1	<b>25.5</b>	104000	2.5	<b>29.7</b>	101000	4.1	<b>44.4</b>	93800	8.2	<b>72</b>	76200	198000	
		<b>394.63</b>	1.9	<b>23.2</b>	106000	2.3	<b>27.1</b>	103000	3.7	<b>40.7</b>	95500	7.3	<b>74</b>	86500	198000	
		<b>435.20</b>	1.7	<b>21.4</b>	107000	2.1	<b>25.0</b>	104000	3.3	<b>37.4</b>	96900	6.7	<b>67</b>	87300	198000	
		<b>502.94</b>	1.5	<b>18.9</b>	109000	1.8	<b>22.1</b>	106000	2.9	<b>33.1</b>	99100	5.8	<b>60</b>	89200	198000	
		<b>577.69</b>	1.3	<b>16.8</b>	112000	1.6	<b>19.6</b>	109000	2.5	<b>29.4</b>	101000	5.0	<b>53</b>	91100	198000	
		<b>612.00</b>	1.2	<b>16.0</b>	113000	1.5	<b>18.7</b>	110000	2.4	<b>28.0</b>	102000	4.7	<b>50</b>	91900	198000	
		<b>698.82</b>	1.1	<b>14.1</b>	113000	1.3	<b>16.7</b>	112000	2.1	<b>25.0</b>	104000	4.1	<b>45.1</b>	93800	198000	
		<b>800.27</b>	0.94	<b>12.3</b>	114000	1.1	<b>14.7</b>	113000	1.8	<b>22.3</b>	106000	3.6	<b>40.2</b>	95700	198000	
	L	<b>887.47</b>	0.85	<b>9.8</b>	100000	1.0	<b>11.5</b>	97500	1.6	<b>17.2</b>	90700	3.3	<b>30.9</b>	81700	175000	
		<b>933.65</b>	0.80	<b>9.4</b>	101000	1.0	<b>11.0</b>	98300	1.6	<b>16.5</b>	91400	3.1	<b>29.6</b>	82300	175000	
	L	<b>1031.68</b>	0.73	<b>8.5</b>	101000	0.9	<b>10.1</b>	99800	1.4	<b>15.1</b>	92800	2.8	<b>27.2</b>	83600	175000	
		<b>1129.41</b>	0.66	<b>8.0</b>	104000	0.8	<b>9.3</b>	101000	1.3	<b>14.0</b>	94100	2.6	<b>25.2</b>	84700	175000	
L	<b>1248.00</b>	0.60	<b>7.1</b>	102000	0.7	<b>8.5</b>	101000	1.2	<b>12.9</b>	95500	2.3	<b>23.2</b>	86000	175000		
<b>RE 8005</b>	L	<b>647.15</b>	1.16	<b>14.9</b>	108000	1.4	<b>17.4</b>	105000	2.2	<b>26.0</b>	97700	4.5	<b>42.3</b>	79400	198000	22 (H-F)
	L	<b>714.10</b>	1.05	<b>14.4</b>	115000	1.3	<b>16.8</b>	112000	2.0	<b>25.2</b>	104000	4.1	<b>42.3</b>	87600	198000	
	L	<b>792.79</b>	0.95	<b>12.5</b>	112000	1.1	<b>14.6</b>	109000	1.8	<b>22.0</b>	101000	3.7	<b>36.1</b>	83100	198000	
	L	<b>890.81</b>	0.84	<b>10.3</b>	103000	1.0	<b>12.3</b>	102000	1.6	<b>19.2</b>	99400	3.3	<b>36.3</b>	93700	198000	
		<b>991.80</b>	0.76	<b>10.9</b>	121000	0.91	<b>12.7</b>	118000	1.5	<b>19.1</b>	110000	2.9	<b>34.4</b>	98900	198000	
	L	<b>1117.88</b>	0.67	<b>8.3</b>	105000	0.81	<b>9.9</b>	103000	1.3	<b>15.5</b>	101000	2.6	<b>29.5</b>	95800	198000	
	L	<b>1266.57</b>	0.59	<b>7.4</b>	105000	0.71	<b>8.8</b>	104000	1.1	<b>13.7</b>	101000	2.3	<b>26.4</b>	97000	198000	
		<b>1416.68</b>	0.53	<b>8.1</b>	128000	0.64	<b>9.4</b>	125000	1.0	<b>14.1</b>	116000	2.0	<b>25.4</b>	104000	198000	
	L	<b>1589.42</b>	0.47	<b>5.4</b>	95700	0.57	<b>6.4</b>	94700	0.91	<b>10.0</b>	92200	1.8	<b>19.2</b>	88600	198000	
		<b>1777.79</b>	0.42	<b>6.6</b>	133000	0.51	<b>7.8</b>	129000	0.82	<b>11.6</b>	120000	1.6	<b>20.9</b>	108000	198000	
		<b>1993.85</b>	0.38	<b>6.0</b>	135000	0.45	<b>7.0</b>	131000	0.73	<b>10.5</b>	122000	1.5	<b>19.0</b>	110000	198000	
	L	<b>2236.25</b>	0.34	<b>4.2</b>	106000	0.40	<b>5.0</b>	104000	0.65	<b>7.8</b>	101000	1.3	<b>14.5</b>	93900	175000	
		<b>2510.77</b>	0.30	<b>5.0</b>	140000	0.36	<b>5.8</b>	136000	0.58	<b>8.7</b>	126000	1.2	<b>15.6</b>	114000	198000	
	L	<b>2813.91</b>	0.27	<b>3.8</b>	119000	0.32	<b>4.4</b>	116000	0.52	<b>6.6</b>	108000	1.0	<b>11.9</b>	97300	175000	
		<b>3164.84</b>	0.24	<b>3.5</b>	124000	0.28	<b>4.1</b>	122000	0.46	<b>6.4</b>	118000	0.92	<b>12.4</b>	114000	198000	

		n <sub>1</sub> = 750 RPM			n <sub>1</sub> = 900 RPM			n <sub>1</sub> = 1450 RPM			n <sub>1</sub> = 2900 RPM			T <sub>2max</sub> [Nm]	P <sub>t</sub> [kW]	
ie		n <sub>2</sub> [RPM]	P <sub>1</sub> [kW]	T <sub>2</sub> [Nm]	n <sub>2</sub> [RPM]	P <sub>1</sub> [kW]	T <sub>2</sub> [Nm]	n <sub>2</sub> [RPM]	P <sub>1</sub> [kW]	T <sub>2</sub> [Nm]	n <sub>2</sub> [RPM]	P <sub>1</sub> [kW]	T <sub>2</sub> [Nm]			
<b>RA 8002</b>		58	<b>233</b>	36000	69	<b>273</b>	35200	112	<b>381</b>	30500	223	<b>619</b>	24800	92200	35 (H-F)	
		15.17	49.5	<b>233</b>	42000	59	<b>273</b>	41100	96	<b>381</b>	35600	191	<b>619</b>	28900		108000
<b>RA 8003</b>	L	<b>44.54</b>	16.8	<b>109</b>	56600	20.2	<b>124</b>	53600	32.6	<b>173</b>	46400	65	<b>282</b>	37700	175000	29 (H-F)
	L	<b>49.14</b>	15.3	<b>109</b>	62400	18.3	<b>124</b>	59100	29.5	<b>173</b>	51200	59	<b>282</b>	41600	175000	
	L	<b>57.33</b>	13.1	<b>108</b>	71600	15.7	<b>124</b>	69000	25.3	<b>173</b>	59800	51	<b>282</b>	48600	175000	
	L	<b>63.89</b>	11.7	<b>105</b>	77600	14.1	<b>124</b>	76800	22.7	<b>173</b>	66600	45.4	<b>282</b>	54100	175000	
	L	<b>67.45</b>	11.1	<b>92</b>	72300	13.3	<b>110</b>	71600	21.5	<b>172</b>	69600	43.0	<b>282</b>	57100	175000	
	L	<b>76.79</b>	9.8	<b>68</b>	60800	11.7	<b>81</b>	60200	18.9	<b>127</b>	58600	37.8	<b>244</b>	56300	158000	
	L	<b>89.58</b>	8.4	<b>68</b>	71000	10.0	<b>81</b>	70200	16.2	<b>127</b>	68400	32.4	<b>242</b>	65200	175000	
	L	<b>97.07</b>	7.7	<b>55</b>	62300	9.3	<b>66</b>	61700	14.9	<b>103</b>	60000	29.9	<b>196</b>	57100	161000	
	L	<b>113.24</b>	6.6	<b>55</b>	72700	7.9	<b>66</b>	71900	12.8	<b>103</b>	70000	25.6	<b>196</b>	66700	175000	
<b>RA 8004</b>	L	<b>151.00</b>	5.0	<b>49.1</b>	83900	6.0	<b>56</b>	79500	9.6	<b>78</b>	68900	19.2	<b>126</b>	55900	175000	24 (H-F)
	L	<b>166.62</b>	4.5	<b>49.1</b>	92600	5.4	<b>56</b>	87700	8.7	<b>78</b>	76000	17.4	<b>126</b>	61700	175000	
	L	<b>176.06</b>	4.3	<b>43.3</b>	86500	5.1	<b>49.2</b>	81900	8.2	<b>69</b>	70900	16.5	<b>112</b>	57600	175000	
	L	<b>194.27</b>	3.9	<b>43.1</b>	94800	4.6	<b>49.2</b>	90300	7.5	<b>69</b>	78300	14.9	<b>112</b>	63600	175000	
	L	<b>228.00</b>	3.3	<b>37.6</b>	97100	3.9	<b>43.9</b>	94500	6.4	<b>62</b>	83500	12.7	<b>101</b>	67800	175000	
	L	<b>252.19</b>	3.0	<b>29.0</b>	82900	3.6	<b>33.9</b>	80600	5.7	<b>51</b>	75100	11.5	<b>95</b>	69900	175000	
	L	<b>265.85</b>	2.8	<b>33.0</b>	99400	3.4	<b>38.5</b>	96700	5.5	<b>58</b>	90000	10.9	<b>109</b>	84500	198000	
	L	<b>280.62</b>	2.7	<b>31.5</b>	100000	3.2	<b>36.8</b>	97500	5.2	<b>55</b>	90700	10.3	<b>103</b>	84800	198000	
	L	<b>312.76</b>	2.4	<b>28.8</b>	102000	2.9	<b>33.6</b>	99100	4.6	<b>50</b>	92200	9.3	<b>93</b>	85300	198000	
	L	<b>361.76</b>	2.1	<b>21.4</b>	87500	2.5	<b>24.9</b>	85100	4.0	<b>37.4</b>	79200	8.0	<b>69</b>	73700	175000	
	L	<b>384.00</b>	2.0	<b>24.2</b>	105000	2.3	<b>28.2</b>	102000	3.8	<b>42.3</b>	95100	7.6	<b>77</b>	86300	198000	
	L	<b>438.48</b>	1.7	<b>21.6</b>	107000	2.1	<b>25.2</b>	104000	3.3	<b>37.8</b>	97000	6.6	<b>68</b>	87400	198000	
	L	<b>516.30</b>	1.5	<b>18.8</b>	110000	1.7	<b>21.9</b>	107000	2.8	<b>32.9</b>	99500	5.6	<b>59</b>	89600	198000	
	L	<b>602.35</b>	1.2	<b>13.9</b>	94500	1.5	<b>16.2</b>	92000	2.4	<b>24.2</b>	85600	4.8	<b>43.6</b>	77000	175000	
	L	<b>685.71</b>	1.1	<b>9.0</b>	70200	1.3	<b>10.5</b>	68300	2.1	<b>16.5</b>	66400	4.2	<b>31.8</b>	63800	158000	
L	<b>800.00</b>	0.94	<b>9.0</b>	81900	1.1	<b>10.5</b>	79700	1.8	<b>16.5</b>	77500	3.6	<b>31.8</b>	74500	175000		

	ie	n <sub>1</sub> = 750 RPM			n <sub>1</sub> = 900 RPM			n <sub>1</sub> = 1450 RPM			n <sub>1</sub> = 2900 RPM			T <sub>2max</sub> [Nm]	P <sub>t</sub> [kW]	
		n <sub>2</sub> [RPM]	P <sub>1</sub> [kW]	T <sub>2</sub> [Nm]	n <sub>2</sub> [RPM]	P <sub>1</sub> [kW]	T <sub>2</sub> [Nm]	n <sub>2</sub> [RPM]	P <sub>1</sub> [kW]	T <sub>2</sub> [Nm]	n <sub>2</sub> [RPM]	P <sub>1</sub> [kW]	T <sub>2</sub> [Nm]			
<b>GB 12011</b>		183	<b>1389</b>	70600	220	<b>1578</b>	66800	354	<b>2204</b>	57900	—	—	—	281000	102 (H-F)	
		143	<b>1132</b>	73800	171	<b>1286</b>	69800	276	<b>1795</b>	60500	—	—	—	233000		
		120	<b>886</b>	68500	144	<b>1052</b>	67800	233	<b>1574</b>	63000	—	—	—	189000		
<b>GB 12012</b>	L	14.83	51	<b>330</b>	59200	61	<b>375</b>	56100	98	<b>524</b>	48600	—	—	—	226000	59 (H-F)
		16.36	45.8	<b>403</b>	79700	55	<b>457</b>	75500	89	<b>639</b>	65400	—	—	—	281000	
	L	19.03	39.4	<b>330</b>	76000	47.3	<b>375</b>	72000	76	<b>524</b>	62400	—	—	—	233000	
	L	21.00	35.7	<b>302</b>	76700	42.9	<b>343</b>	72700	69	<b>479</b>	63000	—	—	—	233000	
	L	22.59	33.2	<b>270</b>	73800	39.8	<b>320</b>	73000	64	<b>502</b>	71000	—	—	—	189000	
	L	24.92	30.1	<b>246</b>	74200	36.1	<b>292</b>	73400	58	<b>458</b>	71400	—	—	—	189000	
	L	27.30	27.5	<b>244</b>	80500	33.0	<b>277</b>	76200	53	<b>387</b>	66100	—	—	—	233000	
	L	32.40	23.1	<b>192</b>	75300	27.8	<b>228</b>	74500	44.8	<b>357</b>	72500	—	—	—	189000	
L	38.94	19.3	<b>161</b>	76100	23.1	<b>192</b>	75300	37.2	<b>301</b>	73300	—	—	—	189000		
<b>GB 12013</b>	L	52.83	14.2	<b>100</b>	62200	17.0	<b>113</b>	58900	27.4	<b>158</b>	51000	—	—	—	212000	42 (H-F)
		58.30	12.9	<b>137</b>	94100	15.4	<b>155</b>	89100	24.9	<b>217</b>	77200	—	—	—	281000	
	L	61.60	12.2	<b>88</b>	64100	14.6	<b>100</b>	60700	23.5	<b>140</b>	52600	—	—	—	212000	
	L	67.80	11.1	<b>100</b>	79800	13.3	<b>113</b>	75600	21.4	<b>158</b>	65500	—	—	—	268000	
	L	79.05	9.5	<b>88</b>	82300	11.4	<b>100</b>	77900	18.3	<b>140</b>	67500	—	—	—	268000	
	L	87.23	8.6	<b>88</b>	90800	10.3	<b>100</b>	85900	16.6	<b>140</b>	74500	—	—	—	233000	
		102.62	7.3	<b>83</b>	100000	8.8	<b>98</b>	99300	14.1	<b>154</b>	96600	—	—	—	233000	
		112.11	6.7	<b>88</b>	116000	8.0	<b>104</b>	115000	12.9	<b>146</b>	100000	—	—	—	281000	
		126.00	6.0	<b>69</b>	102000	7.1	<b>81</b>	100000	11.5	<b>127</b>	97800	—	—	—	233000	
		143.88	5.2	<b>62</b>	105000	6.3	<b>72</b>	102000	10.1	<b>112</b>	98500	—	—	—	233000	
	L	158.98	4.7	<b>56</b>	106000	5.7	<b>66</b>	103000	9.1	<b>102</b>	99100	—	—	—	233000	
	L	170.90	4.4	<b>41.8</b>	84300	5.3	<b>48.8</b>	82000	8.5	<b>76</b>	79700	—	—	—	189000	
	L	198.61	3.8	<b>36.8</b>	86200	4.5	<b>42.9</b>	83900	7.3	<b>66</b>	80400	—	—	—	189000	
L	222.17	3.4	<b>33.5</b>	87700	4.1	<b>39.0</b>	85300	6.5	<b>60</b>	80900	—	—	—	189000		
<b>GB 12014</b>	L	209.86	3.6	<b>57</b>	138000	4.3	<b>65</b>	131000	6.9	<b>91</b>	113000	13.8	<b>147</b>	92100	281000	33 (H-F)
		224.53	3.3	<b>37.2</b>	96000	4.0	<b>42.2</b>	90900	6.5	<b>59</b>	78800	12.9	<b>96</b>	64000	212000	
		247.76	3.0	<b>51</b>	145000	3.6	<b>58</b>	138000	5.9	<b>81</b>	119000	11.7	<b>131</b>	96800	281000	
		288.88	2.6	<b>44.4</b>	148000	3.1	<b>51</b>	142000	5.0	<b>71</b>	123000	10.0	<b>116</b>	99700	281000	
		310.91	2.4	<b>41.4</b>	148000	2.9	<b>49.2</b>	147000	4.7	<b>69</b>	128000	9.3	<b>112</b>	104000	281000	
		354.68	2.1	<b>32.3</b>	132000	2.5	<b>38.4</b>	131000	4.1	<b>60</b>	127000	8.2	<b>98</b>	104000	281000	
	L	399.00	1.9	<b>26.6</b>	122000	2.3	<b>31.0</b>	119000	3.6	<b>46.5</b>	110000	7.3	<b>82</b>	97000	233000	
		445.09	1.7	<b>26.1</b>	134000	2.0	<b>31.0</b>	132000	3.3	<b>48.6</b>	129000	6.5	<b>84</b>	111000	281000	
		495.80	1.5	<b>22.2</b>	127000	1.8	<b>26.3</b>	125000	2.9	<b>41.3</b>	122000	5.8	<b>79</b>	117000	281000	
		561.09	1.3	<b>19.9</b>	128000	1.6	<b>23.2</b>	125000	2.6	<b>34.8</b>	116000	5.2	<b>63</b>	105000	233000	
		636.27	1.2	<b>17.9</b>	131000	1.4	<b>20.9</b>	127000	2.3	<b>31.3</b>	118000	4.6	<b>56</b>	107000	233000	
		720.00	1.0	<b>16.1</b>	133000	1.3	<b>18.8</b>	130000	2.0	<b>28.2</b>	121000	4.0	<b>51</b>	109000	233000	
		803.25	0.93	<b>14.7</b>	136000	1.1	<b>17.1</b>	132000	1.8	<b>25.7</b>	123000	3.6	<b>46.2</b>	110000	233000	
		892.03	0.84	<b>13.4</b>	138000	1.0	<b>15.7</b>	134000	1.6	<b>23.5</b>	125000	3.3	<b>42.3</b>	112000	233000	
	L	998.40	0.75	<b>9.8</b>	113000	0.90	<b>11.7</b>	112000	1.5	<b>18.3</b>	109000	2.9	<b>35.2</b>	105000	233000	
		1050.35	0.71	<b>11.7</b>	141000	0.86	<b>13.6</b>	137000	1.4	<b>20.4</b>	128000	2.8	<b>36.8</b>	115000	233000	
	L	1134.89	0.66	<b>8.4</b>	110000	0.79	<b>9.9</b>	107000	1.3	<b>15.0</b>	102000	2.6	<b>27.1</b>	91000	189000	
	1270.59	0.59	<b>9.9</b>	145000	0.71	<b>11.6</b>	141000	1.1	<b>17.4</b>	132000	2.3	<b>31.3</b>	118000	233000		
L	1415.12	0.53	<b>7.1</b>	116000	0.64	<b>8.3</b>	113000	1.0	<b>12.5</b>	105000	2.0	<b>22.5</b>	95000	189000		
	1507.95	0.50	<b>6.8</b>	117000	0.60	<b>7.9</b>	114000	1.0	<b>11.8</b>	106000	1.9	<b>21.3</b>	96000	189000		
<b>GB 12015</b>	L	661.86	1.13	<b>14.9</b>	111000	1.36	<b>17.4</b>	108000	2.2	<b>26.0</b>	100000	4.4	<b>42.3</b>	81000	212000	27 (H-F)
		730.33	1.03	<b>19.9</b>	163000	1.23	<b>23.3</b>	159000	2.0	<b>35.4</b>	150000	4.0	<b>63.2</b>	134000	281000	
		894.68	0.84	<b>16.8</b>	168000	1.01	<b>19.6</b>	164000	1.6	<b>29.3</b>	152000	3.2	<b>54.8</b>	142000	281000	
		1005.31	0.75	<b>15.0</b>	169000	0.90	<b>17.7</b>	167000	1.4	<b>26.6</b>	155000	2.9	<b>49.7</b>	145000	281000	
		1148.18	0.65	<b>11.1</b>	143000	0.78	<b>13.0</b>	139000	1.3	<b>19.4</b>	130000	2.5	<b>35.0</b>	117000	233000	
		1257.78	0.60	<b>12.6</b>	177000	0.72	<b>14.7</b>	172000	1.2	<b>22.0</b>	160000	2.3	<b>40.7</b>	149000	281000	
		1411.73	0.53	<b>10.9</b>	172000	0.64	<b>12.9</b>	170000	1.03	<b>19.9</b>	163000	2.1	<b>36.5</b>	150000	281000	
	L	1580.48	0.47	<b>8.5</b>	150000	0.57	<b>9.9</b>	146000	0.92	<b>14.8</b>	136000	1.8	<b>26.7</b>	122000	233000	
		1783.84	0.42	<b>8.6</b>	172000	0.50	<b>10.2</b>	170000	0.81	<b>16.0</b>	165000	1.6	<b>29.4</b>	152000	281000	
		2001.18	0.37	<b>6.9</b>	156000	0.45	<b>8.1</b>	151000	0.72	<b>12.1</b>	141000	1.4	<b>21.8</b>	127000	233000	
		2238.55	0.34	<b>7.7</b>	193000	0.40	<b>9.0</b>	188000	0.65	<b>13.5</b>	175000	1.3	<b>24.3</b>	158000	281000	
		2516.27	0.30	<b>5.7</b>	161000	0.36	<b>6.7</b>	157000	0.58	<b>10.0</b>	146000	1.2	<b>18.0</b>	131000	233000	
		2814.15	0.27	<b>5.2</b>	164000	0.32	<b>6.1</b>	159000	0.52	<b>9.1</b>	148000	1.0	<b>16.4</b>	134000	233000	
		3157.67	0.24	<b>4.7</b>	167000	0.29	<b>5.5</b>	162000	0.46	<b>8.2</b>	151000	0.92	<b>14.8</b>	136000	233000	
L	3544.35	0.21	<b>3.4</b>	133000	0.25	<b>3.9</b>	130000	0.41	<b>5.9</b>	121000	0.82	<b>10.6</b>	109000	189000		

	ie	n <sub>1</sub> = 750 RPM			n <sub>1</sub> = 900 RPM			n <sub>1</sub> = 1450 RPM			n <sub>1</sub> = 2900 RPM			T <sub>2max</sub> [Nm]	P <sub>t</sub> [kW]
		n <sub>2</sub> [RPM]	P <sub>1</sub> [kW]	T <sub>2</sub> [Nm]	n <sub>2</sub> [RPM]	P <sub>1</sub> [kW]	T <sub>2</sub> [Nm]	n <sub>2</sub> [RPM]	P <sub>1</sub> [kW]	T <sub>2</sub> [Nm]	n <sub>2</sub> [RPM]	P <sub>1</sub> [kW]	T <sub>2</sub> [Nm]		
GBA 12013	L 45.55	16.5	<b>109</b>	57900	19.8	<b>124</b>	54800	31.8	<b>173</b>	47500	64	<b>282</b>	38600	180000	36 (H-F)
	L 50.26	14.9	<b>109</b>	63900	17.9	<b>124</b>	60500	28.9	<b>173</b>	52400	58	<b>282</b>	42600	198000	
	L 58.45	12.8	<b>109</b>	74300	15.4	<b>124</b>	70300	24.8	<b>173</b>	60900	49.6	<b>282</b>	49500	230000	
	L 64.50	11.6	<b>109</b>	82000	14.0	<b>124</b>	77600	22.5	<b>173</b>	67200	45.0	<b>282</b>	54600	233000	
	L 69.37	10.8	<b>98</b>	78600	13.0	<b>116</b>	77800	20.9	<b>173</b>	72300	41.8	<b>282</b>	58700	189000	
	L 75.88	9.9	<b>109</b>	96400	11.9	<b>124</b>	91300	19.1	<b>173</b>	79100	38.2	<b>282</b>	64300	233000	
	L 83.85	8.9	<b>102</b>	99200	10.7	<b>121</b>	98200	17.3	<b>173</b>	87400	34.6	<b>282</b>	71000	233000	
	L 90.06	8.3	<b>76</b>	79800	10.0	<b>91</b>	79000	16.1	<b>142</b>	76900	32.2	<b>273</b>	73900	189000	
	L 99.51	7.5	<b>69</b>	80300	9.0	<b>82</b>	79400	14.6	<b>129</b>	77300	29.1	<b>248</b>	74300	189000	
	L 116.31	6.4	<b>55</b>	74700	7.7	<b>66</b>	73900	12.5	<b>103</b>	71900	24.9	<b>196</b>	68500	189000	
	L 127.40	5.9	<b>55</b>	81800	7.1	<b>66</b>	80900	11.4	<b>103</b>	78800	22.8	<b>196</b>	75000	211000	
L 136.83	5.5	<b>51</b>	81800	6.6	<b>61</b>	80900	10.6	<b>96</b>	78700	21.2	<b>184</b>	75700	189000		
GBA 12014	L 154.43	4.9	<b>49.1</b>	85800	5.8	<b>56</b>	81300	9.4	<b>78</b>	70400	18.8	<b>126</b>	57200	200000	30 (H-F)
	L 170.40	4.4	<b>67</b>	130000	5.3	<b>76</b>	123000	8.5	<b>107</b>	107000	17.0	<b>173</b>	86500	281000	
	L 198.69	3.8	<b>59</b>	134000	4.5	<b>68</b>	127000	7.3	<b>94</b>	110000	14.6	<b>153</b>	89100	281000	
	L 218.68	3.4	<b>44.9</b>	111000	4.1	<b>52</b>	108000	6.6	<b>78</b>	99700	13.3	<b>126</b>	81000	233000	
	L 254.98	2.9	<b>39.4</b>	114000	3.5	<b>46.1</b>	111000	5.7	<b>69</b>	103000	11.4	<b>112</b>	83500	233000	
	L 286.99	2.6	<b>37.7</b>	123000	3.1	<b>44.8</b>	121000	5.1	<b>70</b>	118000	10.1	<b>130</b>	109000	281000	
	L 313.06	2.4	<b>32.3</b>	115000	2.9	<b>38.4</b>	113000	4.6	<b>58</b>	106000	9.3	<b>95</b>	86800	233000	
	L 348.92	2.1	<b>30.2</b>	120000	2.6	<b>35.3</b>	116000	4.2	<b>53</b>	108000	8.3	<b>90</b>	91700	233000	
	L 392.73	1.9	<b>28.1</b>	125000	2.3	<b>33.3</b>	124000	3.7	<b>52</b>	120000	7.4	<b>100</b>	116000	281000	
	L 448.44	1.7	<b>24.8</b>	126000	2.0	<b>29.4</b>	125000	3.2	<b>46.1</b>	121000	6.5	<b>89</b>	116000	281000	
	L 504.00	1.5	<b>22.1</b>	126000	1.8	<b>25.8</b>	123000	2.9	<b>38.7</b>	114000	5.8	<b>70</b>	103000	233000	
	L 575.50	1.3	<b>19.8</b>	129000	1.6	<b>23.1</b>	125000	2.5	<b>34.6</b>	117000	5.0	<b>62</b>	105000	233000	
	L 635.93	1.2	<b>16.0</b>	115000	1.4	<b>18.9</b>	113000	2.3	<b>29.6</b>	110000	4.6	<b>57</b>	106000	233000	
	L 677.65	1.1	<b>11.7</b>	106000	1.3	<b>20.1</b>	129000	2.1	<b>30.1</b>	120000	4.3	<b>54</b>	108000	233000	
	L 794.42	0.94	<b>17.2</b>	132000	1.1	<b>13.8</b>	103000	1.8	<b>20.7</b>	96300	3.7	<b>37.2</b>	86700	189000	
	L 888.69	0.84	<b>10.7</b>	108000	1.0	<b>12.5</b>	105000	1.6	<b>18.8</b>	97900	3.3	<b>33.9</b>	88200	189000	
GBA 12015	L 584.62	1.3	<b>24.4</b>	158000	1.5	<b>28.5</b>	154000	2.5	<b>44.3</b>	148000	5.0	<b>75</b>	125000	281000	25 (H-F)
	L 625.47	1.2	<b>15.9</b>	110000	1.4	<b>18.5</b>	107000	2.3	<b>27.8</b>	99300	4.6	<b>48.7</b>	87000	200000	
	L 690.18	1.1	<b>21.2</b>	162000	1.3	<b>24.8</b>	157000	2.1	<b>37.9</b>	149000	4.2	<b>67</b>	132000	281000	
	L 804.74	0.93	<b>18.6</b>	166000	1.1	<b>21.8</b>	161000	1.8	<b>32.8</b>	151000	3.6	<b>59</b>	136000	281000	
	L 885.73	0.85	<b>14.1</b>	138000	1.0	<b>16.4</b>	134000	1.6	<b>24.6</b>	125000	3.3	<b>44.3</b>	112000	232000	
	L 991.02	0.76	<b>15.6</b>	171000	0.91	<b>18.2</b>	166000	1.5	<b>27.3</b>	155000	2.9	<b>51.8</b>	147000	281000	
	L 1124.31	0.67	<b>11.2</b>	139000	0.80	<b>13.3</b>	137000	1.3	<b>20.0</b>	128000	2.6	<b>38.2</b>	123000	281000	
	L 1243.64	0.60	<b>12.9</b>	177000	0.72	<b>15.0</b>	172000	1.2	<b>22.5</b>	160000	2.3	<b>41.8</b>	149000	281000	
	L 1413.82	0.53	<b>9.4</b>	147000	0.64	<b>11.0</b>	143000	1.0	<b>16.5</b>	133000	2.1	<b>30.8</b>	124000	281000	
	L 1591.20	0.47	<b>8.6</b>	150000	0.57	<b>10.0</b>	146000	0.91	<b>15.0</b>	136000	1.8	<b>27.0</b>	123000	233000	
	L 1780.36	0.42	<b>7.4</b>	145000	0.51	<b>8.7</b>	143000	0.81	<b>13.7</b>	139000	1.6	<b>26.3</b>	134000	281000	
	L 1983.18	0.38	<b>7.1</b>	155000	0.45	<b>8.2</b>	150000	0.73	<b>12.4</b>	140000	1.5	<b>22.4</b>	127000	281000	
	L 2237.63	0.34	<b>5.1</b>	126000	0.40	<b>6.1</b>	125000	0.65	<b>9.5</b>	121000	1.3	<b>18.3</b>	117000	189000	
	L 2342.31	0.32	<b>5.6</b>	145000	0.38	<b>6.6</b>	143000	0.62	<b>10.4</b>	139000	1.2	<b>19.3</b>	129000	262000	
	L 2516.97	0.30	<b>5.6</b>	157000	0.36	<b>6.7</b>	155000	0.58	<b>10.1</b>	146000	1.2	<b>18.3</b>	131000	233000	
	L 2816.20	0.27	<b>4.0</b>	125000	0.32	<b>4.8</b>	123000	0.51	<b>7.5</b>	120000	1.0	<b>14.4</b>	115000	281000	
	L 3161.48	0.24	<b>3.7</b>	129000	0.28	<b>4.3</b>	125000	0.46	<b>6.5</b>	117000	0.92	<b>11.7</b>	106000	189000	

		n <sub>1</sub> = 750 RPM			n <sub>1</sub> = 900 RPM			n <sub>1</sub> = 1450 RPM			n <sub>1</sub> = 2900 RPM			T <sub>2max</sub> [Nm]	P <sub>t</sub> [kW]	
		ie	n <sub>2</sub> [RPM]	P <sub>1</sub> [kW]	T <sub>2</sub> [Nm]	n <sub>2</sub> [RPM]	P <sub>1</sub> [kW]	T <sub>2</sub> [Nm]	n <sub>2</sub> [RPM]	P <sub>1</sub> [kW]	T <sub>2</sub> [Nm]	n <sub>2</sub> [RPM]	P <sub>1</sub> [kW]			T <sub>2</sub> [Nm]
<b>GB 16001</b>		<b>3.83</b>	196	<b>1956</b>	93100	235	<b>2222</b>	88100	378	<b>3103</b>	76400	—	—	—	345000	109 (H-F)
		<b>4.40</b>	170	<b>1746</b>	95400	205	<b>1983</b>	90300	330	<b>2770</b>	78300	—	—	—	357000	
<b>GB 16002</b>	L	<b>14.72</b>	51	<b>616</b>	110000	61	<b>700</b>	104000	99	<b>977</b>	90100	—	—	—	345000	66 (H-F)
	L	<b>16.90</b>	44.4	<b>462</b>	94600	53	<b>525</b>	89500	86	<b>733</b>	77600	—	—	—	357000	
	L	<b>18.16</b>	41.3	<b>389</b>	85500	49.6	<b>442</b>	81000	80	<b>617</b>	70200	—	—	—	306000	
	L	<b>20.84</b>	36.0	<b>389</b>	98200	43.2	<b>442</b>	93000	70	<b>617</b>	80600	—	—	—	357000	
	L	<b>22.78</b>	32.9	<b>482</b>	133000	39.5	<b>548</b>	126000	64	<b>765</b>	109000	—	—	—	357000	
<b>GB 16003</b>		<b>50.47</b>	14.9	<b>233</b>	139000	17.8	<b>265</b>	132000	28.7	<b>370</b>	114000	—	—	—	345000	48 (H-F)
		<b>57.93</b>	12.9	<b>217</b>	149000	15.5	<b>258</b>	147000	25.0	<b>370</b>	131000	—	—	—	357000	
	L	<b>64.69</b>	11.6	<b>137</b>	104000	13.9	<b>155</b>	98900	22.4	<b>217</b>	85700	—	—	—	306000	
		<b>69.12</b>	10.9	<b>184</b>	150000	13.0	<b>218</b>	149000	21.0	<b>322</b>	136000	—	—	—	357000	
		<b>78.09</b>	9.6	<b>164</b>	151000	11.5	<b>195</b>	150000	18.6	<b>305</b>	146000	—	—	—	357000	
		<b>88.70</b>	8.5	<b>145</b>	152000	10.1	<b>173</b>	151000	16.3	<b>263</b>	142000	—	—	—	357000	
	L	<b>106.29</b>	7.1	<b>102</b>	128000	8.5	<b>116</b>	122000	13.6	<b>162</b>	105000	—	—	—	357000	
		<b>123.64</b>	6.1	<b>98</b>	142000	7.3	<b>116</b>	141000	11.7	<b>182</b>	137000	—	—	—	345000	
	L	<b>141.91</b>	5.3	<b>95</b>	159000	6.3	<b>111</b>	155000	10.2	<b>174</b>	151000	—	—	—	357000	
L	<b>164.06</b>	4.6	<b>59</b>	114000	5.5	<b>70</b>	113000	8.8	<b>110</b>	110000	—	—	—	282000		
<b>GB 16004</b>		<b>181.69</b>	4.1	<b>82</b>	172000	5.0	<b>93</b>	162000	8.0	<b>130</b>	141000	16.0	<b>211</b>	114000	345000	37 (H-F)
		<b>208.54</b>	3.6	<b>70</b>	168000	4.3	<b>82</b>	163000	7.0	<b>124</b>	154000	13.9	<b>211</b>	131000	357000	
	L	<b>222.87</b>	3.4	<b>51</b>	131000	4.0	<b>58</b>	124000	6.5	<b>81</b>	107000	13.0	<b>131</b>	87100	345000	
		<b>255.93</b>	2.9	<b>68</b>	201000	3.5	<b>80</b>	195000	5.7	<b>114</b>	174000	11.3	<b>185</b>	141000	345000	
		<b>281.13</b>	2.7	<b>52</b>	170000	3.2	<b>62</b>	168000	5.2	<b>95</b>	159000	10.3	<b>180</b>	150000	357000	
		<b>319.33</b>	2.3	<b>49.0</b>	179000	2.8	<b>57</b>	174000	4.5	<b>85</b>	162000	9.1	<b>160</b>	152000	357000	
		<b>359.16</b>	2.1	<b>41.0</b>	169000	2.5	<b>48.6</b>	167000	4.0	<b>76</b>	163000	8.1	<b>137</b>	147000	357000	
	L	<b>396.00</b>	1.9	<b>33.2</b>	151000	2.3	<b>39.4</b>	150000	3.7	<b>62</b>	146000	7.3	<b>112</b>	132000	350000	
	L	<b>451.75</b>	1.7	<b>29.4</b>	153000	2.0	<b>34.8</b>	151000	3.2	<b>55</b>	147000	6.4	<b>98</b>	132000	357000	
		<b>496.94</b>	1.5	<b>30.6</b>	176000	1.8	<b>36.5</b>	174000	2.9	<b>57</b>	169000	5.8	<b>106</b>	156000	357000	
		<b>561.47</b>	1.3	<b>25.2</b>	163000	1.6	<b>30.0</b>	162000	2.6	<b>47.0</b>	157000	5.2	<b>90</b>	151000	357000	
		<b>637.74</b>	1.2	<b>24.4</b>	178000	1.4	<b>28.8</b>	176000	2.3	<b>45.1</b>	171000	4.5	<b>85</b>	162000	357000	
		<b>698.82</b>	1.1	<b>22.3</b>	180000	1.3	<b>26.4</b>	177000	2.1	<b>41.4</b>	172000	4.1	<b>79</b>	164000	357000	
	L	<b>797.21</b>	0.94	<b>18.1</b>	166000	1.1	<b>21.2</b>	162000	1.8	<b>31.9</b>	152000	3.6	<b>61</b>	146000	357000	
		<b>896.82</b>	0.84	<b>18.1</b>	187000	1.0	<b>21.1</b>	182000	1.6	<b>32.7</b>	175000	3.2	<b>63</b>	168000	357000	
	<b>1064.36</b>	0.70	<b>15.6</b>	192000	0.85	<b>18.3</b>	187000	1.4	<b>27.8</b>	177000	2.7	<b>54</b>	170000	357000		
L	<b>1241.76</b>	0.60	<b>8.3</b>	118000	0.72	<b>9.6</b>	115000	1.2	<b>14.5</b>	107000	2.3	<b>27.8</b>	103000	247000		
<b>GB 16005</b>		<b>632.27</b>	1.2	<b>29.3</b>	208000	1.4	<b>33.3</b>	197000	2.3	<b>46.4</b>	171000	4.6	<b>76</b>	139000	345000	31 (H-F)
		<b>725.74</b>	1.0	<b>25.0</b>	203000	1.2	<b>29.1</b>	197000	2.0	<b>43.5</b>	184000	4.0	<b>76</b>	159000	357000	
	L	<b>804.82</b>	0.93	<b>18.9</b>	171000	1.1	<b>22.5</b>	169000	1.8	<b>33.7</b>	158000	3.6	<b>55</b>	128000	345000	
		<b>890.63</b>	0.84	<b>23.6</b>	236000	1.0	<b>27.6</b>	230000	1.6	<b>41.3</b>	214000	3.3	<b>76</b>	195000	345000	
		<b>978.32</b>	0.77	<b>17.2</b>	189000	0.92	<b>20.1</b>	184000	1.5	<b>31.0</b>	176000	3.0	<b>59</b>	169000	357000	
		<b>1117.65</b>	0.67	<b>17.8</b>	223000	0.81	<b>21.2</b>	221000	1.3	<b>33.1</b>	215000	2.6	<b>63</b>	204000	345000	
		<b>1252.35</b>	0.60	<b>15.6</b>	220000	0.72	<b>18.3</b>	214000	1.2	<b>27.4</b>	199000	2.3	<b>49.4</b>	180000	357000	
		<b>1414.88</b>	0.53	<b>12.6</b>	200000	0.64	<b>14.7</b>	195000	1.0	<b>22.0</b>	181000	2.0	<b>42.0</b>	172000	357000	
	L	<b>1595.75</b>	0.47	<b>10.1</b>	180000	0.56	<b>11.8</b>	177000	0.91	<b>18.6</b>	172000	1.8	<b>35.7</b>	165000	357000	
		<b>1782.44</b>	0.42	<b>11.0</b>	221000	0.50	<b>13.1</b>	219000	0.81	<b>20.3</b>	210000	1.6	<b>36.6</b>	189000	357000	
		<b>2003.10</b>	0.37	<b>8.6</b>	193000	0.45	<b>10.2</b>	191000	0.72	<b>16.0</b>	186000	1.4	<b>30.7</b>	179000	345000	
		<b>2224.48</b>	0.34	<b>8.6</b>	214000	0.40	<b>10.2</b>	212000	0.65	<b>16.0</b>	206000	1.3	<b>30.4</b>	196000	357000	
	L	<b>2510.41</b>	0.30	<b>6.8</b>	193000	0.36	<b>8.0</b>	188000	0.58	<b>12.1</b>	176000	1.2	<b>23.3</b>	170000	357000	
	L	<b>2809.54</b>	0.27	<b>6.1</b>	190000	0.32	<b>7.0</b>	185000	0.52	<b>11.0</b>	180000	1.0	<b>20.1</b>	164000	357000	
		<b>3172.87</b>	0.24	<b>6.7</b>	240000	0.28	<b>7.9</b>	234000	0.46	<b>12.0</b>	221000	0.91	<b>22.5</b>	207000	357000	

		n <sub>1</sub> = 750 RPM			n <sub>1</sub> = 900 RPM			n <sub>1</sub> = 1450 RPM			n <sub>1</sub> = 2900 RPM			T <sub>2max</sub> [Nm]	P <sub>t</sub> [kW]	
	ie	n <sub>2</sub> [RPM]	P <sub>1</sub> [kW]	T <sub>2</sub> [Nm]	n <sub>2</sub> [RPM]	P <sub>1</sub> [kW]	T <sub>2</sub> [Nm]	n <sub>2</sub> [RPM]	P <sub>1</sub> [kW]	T <sub>2</sub> [Nm]	n <sub>2</sub> [RPM]	P <sub>1</sub> [kW]	T <sub>2</sub> [Nm]			
<b>GBA 16003</b>	L	<b>47.84</b>	15.7	<b>211</b>	117000	18.8	<b>240</b>	111000	30.3	<b>335</b>	96300	61	<b>544</b>	78200	338000	42 (H-F)
	L	<b>54.91</b>	13.7	<b>211</b>	135000	16.4	<b>240</b>	127000	26.4	<b>335</b>	111000	53	<b>544</b>	89800	356000	
		<b>64.49</b>	11.6	<b>183</b>	137000	14.0	<b>217</b>	136000	22.5	<b>341</b>	132000	45.0	<b>568</b>	110000	338000	
		<b>74.02</b>	10.1	<b>175</b>	151000	12.2	<b>208</b>	149000	19.6	<b>326</b>	145000	39.2	<b>568</b>	126000	356000	
	L	<b>77.76</b>	9.6	<b>121</b>	110000	11.6	<b>144</b>	109000	18.6	<b>226</b>	106000	37.3	<b>410</b>	95700	282000	
	L	<b>92.40</b>	8.1	<b>89</b>	95600	9.7	<b>106</b>	95000	15.7	<b>166</b>	92000	31.4	<b>319</b>	88500	247000	
<b>GBA 16004</b>		<b>155.01</b>	4.8	<b>106</b>	186000	5.8	<b>124</b>	181000	9.4	<b>176</b>	160000	18.7	<b>285</b>	130000	338000	35 (H-F)
		<b>184.96</b>	4.1	<b>91</b>	191000	4.9	<b>106</b>	186000	7.8	<b>153</b>	166000	15.7	<b>248</b>	135000	338000	
		<b>212.30</b>	3.5	<b>70</b>	169000	4.2	<b>82</b>	164000	6.8	<b>124</b>	154000	13.7	<b>238</b>	148000	356000	
	L	<b>220.47</b>	3.4	<b>51</b>	128000	4.1	<b>61</b>	127000	6.6	<b>94</b>	122000	13.2	<b>153</b>	98900	306000	
		<b>249.33</b>	3.0	<b>52</b>	148000	3.6	<b>62</b>	147000	5.8	<b>98</b>	143000	11.6	<b>188</b>	137000	338000	
		<b>281.02</b>	2.7	<b>57</b>	180000	3.2	<b>67</b>	179000	5.2	<b>105</b>	174000	10.3	<b>185</b>	153000	338000	
		<b>317.49</b>	2.4	<b>41.8</b>	150000	2.8	<b>49.6</b>	149000	4.6	<b>78</b>	145000	9.1	<b>149</b>	139000	338000	
		<b>360.64</b>	2.1	<b>43.5</b>	178000	2.5	<b>52</b>	176000	4.0	<b>81</b>	171000	8.0	<b>151</b>	160000	338000	
		<b>413.95</b>	1.8	<b>39.7</b>	186000	2.2	<b>46.4</b>	181000	3.5	<b>70</b>	169000	7.0	<b>127</b>	154000	356000	
		<b>435.88</b>	1.7	<b>35.3</b>	174000	2.1	<b>41.9</b>	172000	3.3	<b>66</b>	168000	6.7	<b>121</b>	154000	356000	
		<b>491.28</b>	1.5	<b>29.1</b>	162000	1.8	<b>34.6</b>	160000	3.0	<b>54</b>	156000	5.9	<b>104</b>	150000	356000	
		<b>558.02</b>	1.3	<b>27.9</b>	177000	1.6	<b>33.2</b>	175000	2.6	<b>52</b>	170000	5.2	<b>97</b>	159000	356000	
		<b>662.27</b>	1.1	<b>23.8</b>	178000	1.4	<b>28.2</b>	177000	2.2	<b>44.3</b>	172000	4.4	<b>84</b>	163000	356000	
<b>GBA 16005</b>		<b>506.13</b>	1.5	<b>29.2</b>	163000	1.8	<b>33.2</b>	155000	2.9	<b>46.4</b>	134000	5.7	<b>75</b>	109000	338000	27 (H-F)
		<b>580.95</b>	1.3	<b>29.2</b>	188000	1.5	<b>33.2</b>	178000	2.5	<b>46.4</b>	154000	5.0	<b>75</b>	125000	356000	
	L	<b>620.85</b>	1.2	<b>24.6</b>	168000	1.4	<b>29.2</b>	167000	2.3	<b>41.1</b>	146000	4.7	<b>67</b>	118000	338000	
		<b>712.94</b>	1.1	<b>29.0</b>	229000	1.3	<b>33.2</b>	218000	2.0	<b>46.4</b>	189000	4.1	<b>75</b>	153000	338000	
		<b>783.14</b>	0.96	<b>21.2</b>	183000	1.1	<b>24.7</b>	178000	1.9	<b>38.8</b>	173000	3.7	<b>75</b>	167000	356000	
		<b>894.67</b>	0.84	<b>22.3</b>	221000	1.0	<b>26.5</b>	218000	1.6	<b>41.5</b>	212000	3.2	<b>75</b>	193000	338000	
		<b>995.33</b>	0.75	<b>19.4</b>	213000	0.90	<b>22.6</b>	207000	1.5	<b>33.9</b>	193000	2.9	<b>55.7</b>	158000	356000	
		<b>1124.51</b>	0.67	<b>15.6</b>	193000	0.80	<b>18.2</b>	188000	1.3	<b>27.6</b>	177000	2.6	<b>53.0</b>	170000	356000	
	L	<b>1258.45</b>	0.60	<b>12.8</b>	178000	0.72	<b>15.0</b>	173000	1.2	<b>22.4</b>	161000	2.3	<b>41.6</b>	150000	356000	
		<b>1415.70</b>	0.53	<b>12.8</b>	200000	0.64	<b>14.9</b>	195000	1.0	<b>22.4</b>	181000	2.0	<b>42.6</b>	172000	356000	
	L	<b>1584.00</b>	0.47	<b>10.5</b>	185000	0.57	<b>12.3</b>	180000	0.92	<b>18.5</b>	167000	1.8	<b>33.5</b>	152000	356000	
		<b>1776.56</b>	0.42	<b>10.6</b>	207000	0.51	<b>12.3</b>	202000	0.82	<b>18.5</b>	188000	1.6	<b>34.4</b>	175000	356000	
		<b>1987.76</b>	0.38	<b>9.6</b>	211000	0.45	<b>11.2</b>	205000	0.73	<b>16.8</b>	191000	1.5	<b>31.0</b>	176000	356000	
		<b>2245.87</b>	0.33	<b>7.1</b>	177000	0.40	<b>8.5</b>	175000	0.65	<b>13.3</b>	170000	1.3	<b>25.5</b>	164000	356000	
		<b>2498.29</b>	0.30	<b>7.9</b>	218000	0.36	<b>9.2</b>	212000	0.58	<b>13.8</b>	197000	1.2	<b>25.0</b>	178000	356000	
		<b>2795.29</b>	0.27	<b>7.2</b>	222000	0.32	<b>8.4</b>	216000	0.52	<b>12.6</b>	201000	1.0	<b>22.6</b>	181000	356000	
		<b>3158.25</b>	0.24	<b>5.3</b>	185000	0.28	<b>6.2</b>	180000	0.46	<b>9.6</b>	174000	0.92	<b>18.5</b>	167000	356000	
	L	<b>3544.35</b>	0.21	<b>3.5</b>	137000	0.25	<b>4.1</b>	135000	0.41	<b>6.5</b>	131000	0.82	<b>12.5</b>	126000	338000	

	ie	n <sub>1</sub> = 750 RPM			n <sub>1</sub> = 900 RPM			n <sub>1</sub> = 1450 RPM			n <sub>1</sub> = 2900 RPM			T <sub>2max</sub> [Nm]	P <sub>t</sub> [kW]
		n <sub>2</sub> [RPM]	P <sub>1</sub> [kW]	T <sub>2</sub> [Nm]	n <sub>2</sub> [RPM]	P <sub>1</sub> [kW]	T <sub>2</sub> [Nm]	n <sub>2</sub> [RPM]	P <sub>1</sub> [kW]	T <sub>2</sub> [Nm]	n <sub>2</sub> [RPM]	P <sub>1</sub> [kW]	T <sub>2</sub> [Nm]		
<b>GB 21001</b>	<b>3.68</b>	204	<b>2071</b>	94600	245	<b>2353</b>	89600	394	<b>3285</b>	77600	—	—	—	406000	133 (H-F)
	<b>4.94</b>	152	<b>1627</b>	99800	182	<b>1848</b>	94500	293	<b>2581</b>	81900	—	—	—	361000	
	<b>5.79*</b>	129	<b>1111</b>	77426	155	<b>1262</b>	73305	250	<b>1763</b>	63533	—	—	—	215000	
<b>GB 21002</b>	<b>15.25</b>	49.2	<b>591</b>	109000	59	<b>672</b>	103000	95	<b>938</b>	89500	—	—	—	406000	78 (H-F)
	<b>20.47</b>	36.6	<b>565</b>	140000	44.0	<b>671</b>	138000	71	<b>938</b>	120000	—	—	—	361000	
	<b>23.92</b>	31.4	<b>393</b>	114000	37.6	<b>464</b>	112000	61	<b>648</b>	97100	—	—	—	314000	
	<b>26.68</b>	28.1	<b>440</b>	142000	33.7	<b>522</b>	141000	54	<b>759</b>	127000	—	—	—	361000	
	<b>32.12</b>	23.4	<b>369</b>	144000	28.0	<b>439</b>	142000	45.1	<b>648</b>	130000	—	—	—	361000	
<b>GB 21003</b>	<b>58.44</b>	12.8	<b>237</b>	163000	15.4	<b>269</b>	155000	24.8	<b>375</b>	134000	—	—	—	406000	56 (H-F)
	<b>80.04</b>	9.4	<b>190</b>	179000	11.2	<b>216</b>	170000	18.1	<b>301</b>	147000	—	—	—	406000	
	<b>91.69</b>	8.2	<b>114</b>	123000	9.8	<b>135</b>	122000	15.8	<b>211</b>	118000	—	—	—	314000	
	<b>102.28</b>	7.3	<b>127</b>	153000	8.8	<b>151</b>	152000	14.2	<b>237</b>	148000	—	—	—	361000	
	<b>107.47</b>	7.0	<b>121</b>	154000	8.4	<b>144</b>	152000	13.5	<b>226</b>	148000	—	—	—	361000	
	<b>123.12</b>	6.1	<b>107</b>	155000	7.3	<b>127</b>	153000	11.8	<b>199</b>	149000	—	—	—	361000	
	<b>140.08</b>	5.4	<b>94</b>	156000	6.4	<b>112</b>	155000	10.4	<b>176</b>	150000	—	—	—	361000	
<b>GB 21004</b>	<b>233.77</b>	3.2	<b>79</b>	212000	3.8	<b>94</b>	210000	6.2	<b>146</b>	203000	12.4	<b>237</b>	165000	406000	44 (H-F)
	<b>265.65</b>	2.8	<b>70</b>	214000	3.4	<b>83</b>	212000	5.5	<b>130</b>	206000	10.9	<b>217</b>	171000	406000	
	<b>313.88</b>	2.4	<b>48.8</b>	176000	2.9	<b>57</b>	171000	4.6	<b>85</b>	160000	9.2	<b>162</b>	151000	361000	
	<b>356.68</b>	2.1	<b>43.8</b>	180000	2.5	<b>51</b>	175000	4.1	<b>77</b>	163000	8.1	<b>144</b>	153000	361000	
	<b>409.13</b>	1.8	<b>39.0</b>	183000	2.2	<b>45.5</b>	178000	3.5	<b>68</b>	166000	7.1	<b>126</b>	154000	361000	
	<b>464.92</b>	1.6	<b>35.0</b>	187000	1.9	<b>40.8</b>	182000	3.1	<b>61</b>	169000	6.2	<b>112</b>	155000	361000	
	<b>502.32</b>	1.5	<b>23.4</b>	135000	1.8	<b>27.8</b>	134000	2.9	<b>43.6</b>	130000	5.8	<b>84</b>	125000	314000	
	<b>560.33</b>	1.3	<b>29.8</b>	192000	1.6	<b>34.8</b>	187000	2.6	<b>52</b>	174000	5.2	<b>94</b>	157000	361000	
	<b>636.74</b>	1.2	<b>26.8</b>	196000	1.4	<b>31.3</b>	191000	2.3	<b>46.8</b>	178000	4.6	<b>84</b>	160000	361000	
	<b>766.44</b>	0.98	<b>20.9</b>	184000	1.2	<b>24.7</b>	181000	1.9	<b>38.7</b>	176000	3.8	<b>72</b>	164000	361000	
<b>GB 21005</b>	<b>841.56</b>	0.89	<b>26.6</b>	251000	1.1	<b>31.0</b>	244000	1.7	<b>46.5</b>	227000	3.4	<b>87</b>	212000	406000	36 (H-F)
	<b>993.51</b>	0.75	<b>23.1</b>	257000	0.91	<b>27.0</b>	250000	1.5	<b>40.4</b>	233000	2.9	<b>74</b>	214000	406000	
	<b>1128.99</b>	0.66	<b>20.7</b>	262000	0.80	<b>24.2</b>	255000	1.3	<b>36.2</b>	237000	2.6	<b>66</b>	215000	406000	
	<b>1246.76</b>	0.60	<b>19.0</b>	266000	0.72	<b>22.2</b>	259000	1.2	<b>33.3</b>	241000	2.3	<b>60</b>	217000	406000	
	<b>1416.77</b>	0.53	<b>17.1</b>	272000	0.64	<b>19.9</b>	264000	1.0	<b>29.9</b>	246000	2.0	<b>54</b>	221000	406000	
	<b>1625.09</b>	0.46	<b>11.9</b>	218000	0.55	<b>13.9</b>	212000	0.89	<b>20.9</b>	197000	1.8	<b>37.8</b>	178000	406000	
	<b>1773.58</b>	0.42	<b>11.1</b>	221000	0.51	<b>12.9</b>	215000	0.82	<b>19.4</b>	200000	1.6	<b>34.9</b>	180000	406000	
	<b>1992.34</b>	0.38	<b>12.8</b>	286000	0.45	<b>14.9</b>	278000	0.73	<b>22.4</b>	259000	1.5	<b>40.3</b>	233000	406000	
	<b>2255.67</b>	0.33	<b>10.5</b>	266000	0.40	<b>12.5</b>	263000	0.64	<b>19.5</b>	256000	1.3	<b>36.3</b>	237000	406000	
	<b>2536.60</b>	0.30	<b>8.5</b>	242000	0.35	<b>9.9</b>	235000	0.57	<b>14.9</b>	219000	1.1	<b>26.8</b>	197000	361000	
	<b>2882.50</b>	0.26	<b>7.6</b>	247000	0.31	<b>8.9</b>	240000	0.50	<b>13.3</b>	223000	1.0	<b>24.0</b>	201000	361000	
	<b>3129.84</b>	0.24	<b>6.8</b>	240000	0.29	<b>8.0</b>	234000	0.46	<b>12.0</b>	218000	0.93	<b>21.6</b>	196000	406000	

\* GB 18001

	ie	n <sub>1</sub> = 750 RPM			n <sub>1</sub> = 900 RPM			n <sub>1</sub> = 1450 RPM			n <sub>1</sub> = 2900 RPM			T <sub>2max</sub> [Nm]	P <sub>t</sub> [kW]
		n <sub>2</sub> [RPM]	P <sub>1</sub> [kW]	T <sub>2</sub> [Nm]	n <sub>2</sub> [RPM]	P <sub>1</sub> [kW]	T <sub>2</sub> [Nm]	n <sub>2</sub> [RPM]	P <sub>1</sub> [kW]	T <sub>2</sub> [Nm]	n <sub>2</sub> [RPM]	P <sub>1</sub> [kW]	T <sub>2</sub> [Nm]		
<b>GBA 21003</b>	<b>49.55</b>	15.1	<b>239</b>	137000	18.2	<b>280</b>	134000	29.3	<b>391</b>	116000	59	<b>634</b>	94500	351000	49 (H-F)
	<b>66.53</b>	11.3	<b>194</b>	150000	13.5	<b>230</b>	148000	21.8	<b>360</b>	144000	43.6	<b>634</b>	127000	361000	
	<b>77.74</b>	9.6	<b>135</b>	122000	11.6	<b>160</b>	120000	18.7	<b>251</b>	117000	37.3	<b>481</b>	112000	314000	
	<b>86.72</b>	8.6	<b>151</b>	152000	10.4	<b>179</b>	150000	16.7	<b>281</b>	146000	33.4	<b>540</b>	141000	361000	
	<b>104.38</b>	7.2	<b>127</b>	154000	8.6	<b>150</b>	152000	13.9	<b>236</b>	148000	27.8	<b>453</b>	142000	361000	
<b>GBA 21004</b>	<b>179.50</b>	4.2	<b>103</b>	209000	5.0	<b>122</b>	207000	8.1	<b>178</b>	187000	16.2	<b>289</b>	152000	351000	40 (H-F)
	<b>233.97</b>	3.2	<b>65</b>	172000	3.8	<b>77</b>	170000	6.2	<b>121</b>	166000	12.4	<b>233</b>	159000	351000	
	<b>245.84</b>	3.1	<b>77</b>	213000	3.7	<b>91</b>	211000	5.9	<b>142</b>	205000	11.8	<b>232</b>	167000	351000	
	<b>272.73</b>	2.7	<b>57</b>	175000	3.3	<b>67</b>	173000	5.3	<b>105</b>	169000	10.6	<b>201</b>	161000	351000	
	<b>314.15</b>	2.4	<b>49.5</b>	176000	2.9	<b>58</b>	171000	4.6	<b>87</b>	160000	9.2	<b>164</b>	151000	361000	
	<b>355.49</b>	2.1	<b>43.8</b>	176000	2.5	<b>52</b>	175000	4.1	<b>82</b>	170000	8.2	<b>157</b>	163000	351000	
	<b>385.71</b>	1.9	<b>30.5</b>	133000	2.4	<b>48.8</b>	174000	3.8	<b>74</b>	164000	7.5	<b>109</b>	123000	314000	
	<b>430.25</b>	1.7	<b>37.9</b>	185000	2.1	<b>44.3</b>	180000	3.4	<b>66</b>	167000	6.7	<b>122</b>	154000	361000	
	<b>501.53</b>	1.5	<b>33.3</b>	189000	1.8	<b>38.9</b>	184000	2.9	<b>58</b>	171000	5.8	<b>106</b>	156000	361000	
	<b>574.55</b>	1.3	<b>27.7</b>	180000	1.6	<b>32.9</b>	178000	2.5	<b>52</b>	174000	5.0	<b>93</b>	157000	361000	
	<b>653.72</b>	1.1	<b>26.6</b>	197000	1.4	<b>31.0</b>	192000	2.2	<b>46.5</b>	178000	4.4	<b>84</b>	161000	361000	
	<b>786.88</b>	1.0	<b>20.7</b>	185000	1.1	<b>24.4</b>	182000	1.8	<b>38.3</b>	177000	3.7	<b>72</b>	165000	361000	
<b>GBA 21005</b>	<b>651.21</b>	1.2	<b>29.2</b>	210000	1.4	<b>33.2</b>	199000	2.2	<b>46.4</b>	173000	4.5	<b>75</b>	140000	351000	32 (H-F)
	<b>740.01</b>	1.0	<b>29.2</b>	239000	1.2	<b>33.2</b>	226000	2.0	<b>46.4</b>	196000	3.9	<b>75</b>	159000	351000	
	<b>891.87</b>	0.84	<b>25.6</b>	252000	1.0	<b>30.0</b>	246000	1.6	<b>45.0</b>	229000	3.3	<b>75</b>	192000	351000	
	<b>993.62</b>	0.75	<b>19.1</b>	210000	0.91	<b>22.3</b>	204000	1.5	<b>33.4</b>	190000	2.9	<b>60</b>	171000	361000	
	<b>1139.72</b>	0.66	<b>17.0</b>	214000	0.79	<b>19.9</b>	208000	1.3	<b>29.8</b>	194000	2.5	<b>54</b>	175000	361000	
	<b>1255.53</b>	0.60	<b>15.7</b>	217000	0.72	<b>18.3</b>	211000	1.2	<b>27.4</b>	197000	2.3	<b>49.4</b>	177000	361000	
	<b>1426.74</b>	0.53	<b>14.1</b>	222000	0.63	<b>16.4</b>	216000	1.0	<b>24.6</b>	201000	2.0	<b>44.3</b>	181000	361000	
	<b>1560.92</b>	0.48	<b>13.0</b>	225000	0.58	<b>15.2</b>	219000	0.93	<b>22.8</b>	203000	1.9	<b>41.1</b>	183000	361000	
	<b>1773.77</b>	0.42	<b>11.7</b>	229000	0.51	<b>13.6</b>	223000	0.82	<b>20.5</b>	207000	1.6	<b>36.8</b>	187000	361000	
	<b>1969.88</b>	0.38	<b>9.8</b>	212000	0.46	<b>11.4</b>	206000	0.74	<b>17.1</b>	192000	1.5	<b>31.8</b>	179000	361000	
	<b>2241.32</b>	0.33	<b>9.6</b>	237000	0.40	<b>11.2</b>	231000	0.65	<b>16.8</b>	215000	1.3	<b>30.2</b>	193000	361000	
	<b>2546.95</b>	0.29	<b>8.6</b>	242000	0.35	<b>10.0</b>	235000	0.57	<b>15.0</b>	219000	1.1	<b>27.1</b>	197000	361000	
	<b>3065.78</b>	0.24	<b>6.7</b>	227000	0.29	<b>7.8</b>	221000	0.47	<b>11.7</b>	205000	0.95	<b>21.1</b>	185000	361000	

	ie	n <sub>1</sub> = 750 RPM			n <sub>1</sub> = 900 RPM			n <sub>1</sub> = 1450 RPM			n <sub>1</sub> = 2900 RPM			T <sub>2max</sub> [Nm]	P <sub>t</sub> [kW]
		n <sub>2</sub> [RPM]	P <sub>1</sub> [kW]	T <sub>2</sub> [Nm]	n <sub>2</sub> [RPM]	P <sub>1</sub> [kW]	T <sub>2</sub> [Nm]	n <sub>2</sub> [RPM]	P <sub>1</sub> [kW]	T <sub>2</sub> [Nm]	n <sub>2</sub> [RPM]	P <sub>1</sub> [kW]	T <sub>2</sub> [Nm]		
<b>GB 26001</b>	<b>3.68</b>	204	<b>2405</b>	110000	245	<b>2733</b>	104000	394	<b>3816</b>	90200	—	—	—	540000	136 (H-F)
	<b>4.94</b>	152	<b>1890</b>	116000	182	<b>2147</b>	110000	293	<b>2998</b>	95100	—	—	—	414000	
<b>GB 26002</b>	<b>14.72</b>	51	<b>810</b>	144000	61	<b>920</b>	137000	99	<b>1284</b>	118000	—	—	—	540000	85 (H-F)
	<b>17.17</b>	43.7	<b>714</b>	148000	52	<b>811</b>	140000	84	<b>1132</b>	122000	—	—	—	540000	
	<b>19.76</b>	37.9	<b>670</b>	160000	45.5	<b>796</b>	159000	73	<b>1165</b>	144000	—	—	—	414000	
	<b>23.06</b>	32.5	<b>580</b>	162000	39.0	<b>688</b>	160000	63	<b>1046</b>	151000	—	—	—	414000	
<b>GB 26003</b>	<b>58.88</b>	12.7	<b>315</b>	219000	15.3	<b>357</b>	207000	24.6	<b>499</b>	179000	—	—	—	540000	61 (H-F)
	<b>69.27</b>	10.8	<b>281</b>	230000	13.0	<b>319</b>	217000	20.9	<b>445</b>	188000	—	—	—	540000	
	<b>80.82</b>	9.3	<b>244</b>	233000	11.1	<b>281</b>	224000	17.9	<b>393</b>	194000	—	—	—	540000	
	<b>92.24</b>	8.1	<b>161</b>	175000	9.8	<b>191</b>	173000	15.7	<b>300</b>	169000	—	—	—	414000	
	<b>108.51</b>	6.9	<b>138</b>	177000	8.3	<b>164</b>	175000	13.4	<b>257</b>	170000	—	—	—	414000	
<b>GB 26004</b>	<b>209.76</b>	3.6	<b>110</b>	264000	4.3	<b>128</b>	257000	6.9	<b>192</b>	239000	13.8	<b>342</b>	213000	540000	48 (H-F)
	<b>246.78</b>	3.0	<b>95</b>	271000	3.6	<b>111</b>	264000	5.9	<b>167</b>	245000	11.8	<b>305</b>	224000	540000	
	<b>287.74</b>	2.6	<b>84</b>	277000	3.1	<b>98</b>	270000	5.0	<b>147</b>	251000	10.1	<b>271</b>	232000	540000	
	<b>328.40</b>	2.3	<b>54</b>	204000	2.7	<b>63</b>	198000	4.4	<b>94</b>	184000	8.8	<b>178</b>	174000	414000	
	<b>353.28</b>	2.1	<b>70</b>	286000	2.5	<b>82</b>	278000	4.1	<b>123</b>	259000	8.2	<b>223</b>	234000	540000	
	<b>400.04</b>	1.9	<b>59</b>	273000	2.2	<b>71</b>	271000	3.6	<b>111</b>	263000	7.2	<b>200</b>	238000	540000	
	<b>450.74</b>	1.7	<b>41.2</b>	214000	2.0	<b>48.1</b>	208000	3.2	<b>72</b>	194000	6.4	<b>132</b>	177000	414000	
	<b>554.16</b>	1.4	<b>44.2</b>	282000	1.6	<b>52</b>	276000	2.6	<b>81</b>	268000	5.2	<b>151</b>	250000	540000	
	<b>631.92</b>	1.2	<b>30.9</b>	225000	1.4	<b>36.1</b>	219000	2.3	<b>54</b>	204000	4.6	<b>98</b>	183000	414000	
	<b>744.08</b>	1.0	<b>26.9</b>	231000	1.2	<b>31.4</b>	224000	1.9	<b>47.1</b>	209000	3.9	<b>85</b>	188000	414000	
<b>GB 26005</b>	<b>755.14</b>	0.99	<b>37.9</b>	321000	1.2	<b>44.2</b>	312000	1.9	<b>66</b>	290000	3.8	<b>119</b>	262000	540000	40 (H-F)
	<b>891.48</b>	0.84	<b>32.9</b>	329000	1.0	<b>38.4</b>	320000	1.6	<b>58</b>	298000	3.3	<b>104</b>	268000	540000	
	<b>1013.93</b>	0.74	<b>21.2</b>	242000	0.89	<b>24.8</b>	235000	1.4	<b>37.2</b>	219000	2.9	<b>67</b>	197000	414000	
	<b>1118.72</b>	0.67	<b>27.1</b>	341000	0.80	<b>31.7</b>	331000	1.3	<b>47.5</b>	308000	2.6	<b>86</b>	278000	540000	
	<b>1261.21</b>	0.59	<b>22.6</b>	319000	0.71	<b>26.4</b>	311000	1.1	<b>39.5</b>	289000	2.3	<b>74</b>	270000	540000	
	<b>1426.71</b>	0.53	<b>20.3</b>	325000	0.63	<b>23.7</b>	317000	1.0	<b>35.6</b>	295000	2.0	<b>66</b>	272000	540000	
	<b>1601.54</b>	0.47	<b>20.0</b>	360000	0.56	<b>23.4</b>	350000	0.91	<b>35.0</b>	325000	1.8	<b>63</b>	293000	540000	
	<b>1783.98</b>	0.42	<b>18.3</b>	366000	0.50	<b>21.3</b>	356000	0.81	<b>32.0</b>	331000	1.6	<b>58</b>	298000	540000	
	<b>1994.99</b>	0.38	<b>15.3</b>	342000	0.45	<b>17.9</b>	333000	0.73	<b>26.8</b>	310000	1.5	<b>48.2</b>	279000	540000	
	<b>2252.16</b>	0.33	<b>15.0</b>	379000	0.40	<b>17.5</b>	368000	0.64	<b>26.2</b>	343000	1.3	<b>47.2</b>	309000	540000	
	<b>2503.24</b>	0.30	<b>12.7</b>	356000	0.36	<b>15.0</b>	352000	0.58	<b>23.6</b>	342000	1.2	<b>43.2</b>	314000	540000	
	<b>2854.49</b>	0.26	<b>8.8</b>	283000	0.32	<b>10.3</b>	275000	0.51	<b>15.4</b>	256000	1.0	<b>27.8</b>	230000	414000	
	<b>3091.20</b>	0.24	<b>10.5</b>	366000	0.29	<b>12.3</b>	356000	0.47	<b>18.5</b>	331000	0.94	<b>33.2</b>	298000	540000	
	<b>3532.80</b>	0.21	<b>9.4</b>	373000	0.25	<b>11.0</b>	363000	0.41	<b>16.5</b>	338000	0.82	<b>29.7</b>	304000	540000	

	ie	n <sub>1</sub> = 750 RPM			n <sub>1</sub> = 900 RPM			n <sub>1</sub> = 1450 RPM			n <sub>1</sub> = 2900 RPM			T <sub>2max</sub> [Nm]	P <sub>t</sub> [kW]
		n <sub>2</sub> [RPM]	P <sub>1</sub> [kW]	T <sub>2</sub> [Nm]	n <sub>2</sub> [RPM]	P <sub>1</sub> [kW]	T <sub>2</sub> [Nm]	n <sub>2</sub> [RPM]	P <sub>1</sub> [kW]	T <sub>2</sub> [Nm]	n <sub>2</sub> [RPM]	P <sub>1</sub> [kW]	T <sub>2</sub> [Nm]		
<b>GBA 26003</b>	<b>55.81</b>	13.4	<b>239</b>	155000	16.1	<b>280</b>	151000	26.0	<b>391</b>	131000	52	<b>634</b>	106000	396000	49 (H-F)
	<b>64.24</b>	11.7	<b>230</b>	172000	14.0	<b>273</b>	170000	22.6	<b>391</b>	151000	45.1	<b>634</b>	122000	414000	
	<b>74.94</b>	10.0	<b>199</b>	173000	12.0	<b>236</b>	171000	19.3	<b>370</b>	167000	38.7	<b>634</b>	143000	414000	
<b>GBA 26004</b>	<b>180.85</b>	4.1	<b>112</b>	230000	5.0	<b>127</b>	218000	8.0	<b>178</b>	189000	16.0	<b>289</b>	153000	540000	42 (H-F)
	<b>212.76</b>	3.5	<b>110</b>	265000	4.2	<b>127</b>	256000	6.8	<b>178</b>	222000	13.6	<b>289</b>	180000	540000	
	<b>248.22</b>	3.0	<b>95</b>	266000	3.6	<b>112</b>	263000	5.8	<b>169</b>	245000	11.7	<b>289</b>	210000	540000	
	<b>285.67</b>	2.6	<b>62</b>	200000	3.2	<b>72</b>	194000	5.1	<b>108</b>	181000	10.2	<b>207</b>	173000	414000	
	<b>320.57</b>	2.3	<b>57</b>	206000	2.8	<b>67</b>	204000	4.5	<b>105</b>	198000	9.0	<b>201</b>	189000	540000	
	<b>368.94</b>	2.0	<b>50</b>	207000	2.4	<b>58</b>	202000	3.9	<b>87</b>	188000	7.9	<b>162</b>	175000	414000	
	<b>434.05</b>	1.7	<b>43.2</b>	213000	2.1	<b>50</b>	207000	3.3	<b>76</b>	192000	6.7	<b>139</b>	177000	414000	
	<b>506.39</b>	1.5	<b>37.9</b>	218000	1.8	<b>44.3</b>	212000	2.9	<b>66</b>	197000	5.7	<b>120</b>	179000	414000	
<b>GBA 26005</b>	<b>613.14</b>	1.2	<b>45.9</b>	311000	1.5	<b>54</b>	303000	2.4	<b>80</b>	281000	4.7	<b>145</b>	253000	540000	36 (H-F)
	<b>714.92</b>	1.0	<b>40.3</b>	318000	1.3	<b>47.0</b>	310000	2.0	<b>71</b>	288000	4.1	<b>127</b>	259000	540000	
	<b>834.08</b>	0.90	<b>32.6</b>	300000	1.1	<b>38.0</b>	292000	1.7	<b>58</b>	275000	3.5	<b>111</b>	264000	540000	
	<b>877.76</b>	0.85	<b>33.9</b>	328000	1.0	<b>39.5</b>	319000	1.7	<b>59</b>	297000	3.3	<b>107</b>	268000	540000	
	<b>987.11</b>	0.76	<b>30.7</b>	334000	0.91	<b>35.8</b>	325000	1.5	<b>54</b>	303000	2.9	<b>97</b>	272000	540000	
	<b>1119.92</b>	0.67	<b>19.8</b>	245000	0.80	<b>23.2</b>	239000	1.3	<b>34.7</b>	222000	2.6	<b>62</b>	200000	414000	
	<b>1201.15</b>	0.62	<b>25.9</b>	344000	0.75	<b>30.3</b>	335000	1.2	<b>45.4</b>	312000	2.4	<b>82</b>	281000	540000	
	<b>1413.12</b>	0.53	<b>22.6</b>	353000	0.64	<b>26.4</b>	343000	1.0	<b>39.6</b>	319000	2.1	<b>71</b>	288000	540000	
	<b>1600.15</b>	0.47	<b>18.7</b>	331000	0.56	<b>21.9</b>	322000	0.91	<b>32.8</b>	300000	1.8	<b>60</b>	274000	540000	
	<b>1802.97</b>	0.42	<b>13.2</b>	264000	0.50	<b>15.5</b>	257000	0.80	<b>23.2</b>	239000	1.6	<b>41.7</b>	215000	414000	
	<b>1899.99</b>	0.39	<b>17.6</b>	369000	0.47	<b>20.5</b>	359000	0.76	<b>30.8</b>	334000	1.5	<b>55</b>	301000	540000	
	<b>2216.66</b>	0.34	<b>14.2</b>	348000	0.41	<b>16.6</b>	338000	0.65	<b>24.9</b>	315000	1.3	<b>44.8</b>	283000	540000	
<b>2527.69</b>	0.30	<b>9.9</b>	278000	0.36	<b>11.6</b>	270000	0.57	<b>17.4</b>	251000	1.1	<b>31.3</b>	226000	414000		

	ie	n <sub>1</sub> = 750 RPM			n <sub>1</sub> = 900 RPM			n <sub>1</sub> = 1450 RPM			n <sub>1</sub> = 2900 RPM			T <sub>2max</sub> [Nm]	P <sub>t</sub> [kW]
		n <sub>2</sub> [RPM]	P <sub>1</sub> [kW]	T <sub>2</sub> [Nm]	n <sub>2</sub> [RPM]	P <sub>1</sub> [kW]	T <sub>2</sub> [Nm]	n <sub>2</sub> [RPM]	P <sub>1</sub> [kW]	T <sub>2</sub> [Nm]	n <sub>2</sub> [RPM]	P <sub>1</sub> [kW]	T <sub>2</sub> [Nm]		
GB 31001	3.43	219	<b>3309</b>	141000	263	<b>3760</b>	133000	—	—	—	—	—	—	549000	214 (H-F)
	4.09	183	<b>2891</b>	147000	220	<b>3285</b>	139000	—	—	—	—	—	—	650000	
	5.25	143	<b>2357</b>	154000	171	<b>2678</b>	145000	—	—	—	—	—	—	526000	
	6.23	120	<b>1968</b>	152000	144	<b>2338</b>	151000	—	—	—	—	—	—	420000	
GB 31002	14.03	53	<b>1266</b>	215000	64	<b>1438</b>	204000	103	<b>2008</b>	176000	—	—	—	549000	125 (H-F)
	18.00	41.7	<b>1015</b>	221000	50	<b>1205</b>	219000	81	<b>1687</b>	190000	—	—	—	549000	
	21.48	34.9	<b>929</b>	242000	41.9	<b>1055</b>	229000	68	<b>1474</b>	198000	—	—	—	650000	
	25.49	29.4	<b>824</b>	254000	35.3	<b>936</b>	241000	57	<b>1307</b>	209000	—	—	—	650000	
	32.71	22.9	<b>536</b>	212000	27.5	<b>636</b>	210000	44.3	<b>998</b>	204000	—	—	—	526000	
38.82	19.3	<b>360</b>	169000	23.2	<b>427</b>	167000	37.3	<b>670</b>	163000	—	—	—	420000		
GB 31003	56.10	13.4	<b>356</b>	236000	16.0	<b>423</b>	233000	25.8	<b>655</b>	224000	—	—	—	549000	89 (H-F)
	66.94	11.2	<b>363</b>	287000	13.4	<b>431</b>	284000	21.7	<b>655</b>	268000	—	—	—	650000	
	78.76	9.5	<b>311</b>	289000	11.4	<b>370</b>	286000	18.4	<b>573</b>	276000	—	—	—	650000	
	85.91	8.7	<b>221</b>	224000	10.5	<b>263</b>	222000	16.9	<b>412</b>	216000	—	—	—	526000	
	101.07	7.4	<b>251</b>	299000	8.9	<b>292</b>	291000	14.3	<b>458</b>	283000	—	—	—	650000	
	110.25	6.8	<b>175</b>	227000	8.2	<b>208</b>	225000	13.2	<b>326</b>	219000	—	—	—	526000	
	129.71	5.8	<b>152</b>	232000	6.9	<b>178</b>	227000	11.2	<b>279</b>	221000	—	—	—	526000	
	153.94	4.9	<b>131</b>	238000	5.8	<b>153</b>	232000	9.4	<b>238</b>	223000	—	—	—	526000	
182.69	4.1	<b>88</b>	189000	4.9	<b>102</b>	184000	7.9	<b>159</b>	178000	—	—	—	420000		
GB 31004	199.87	3.8	<b>122</b>	282000	4.5	<b>143</b>	274000	7.3	<b>214</b>	255000	14.5	<b>362</b>	215000	549000	69 (H-F)
	233.05	3.2	<b>108</b>	288000	3.9	<b>126</b>	280000	6.2	<b>188</b>	261000	12.4	<b>319</b>	222000	549000	
	256.50	2.9	<b>99</b>	293000	3.5	<b>116</b>	285000	5.7	<b>173</b>	265000	11.3	<b>312</b>	238000	549000	
	280.57	2.7	<b>108</b>	349000	3.2	<b>126</b>	339000	5.2	<b>189</b>	316000	10.3	<b>345</b>	288000	650000	
	327.14	2.3	<b>95</b>	357000	2.8	<b>111</b>	347000	4.4	<b>166</b>	323000	8.9	<b>299</b>	291000	650000	
	356.85	2.1	<b>88</b>	362000	2.5	<b>103</b>	352000	4.1	<b>154</b>	327000	8.1	<b>278</b>	295000	650000	
	401.65	1.9	<b>80</b>	368000	2.2	<b>93</b>	358000	3.6	<b>139</b>	333000	7.2	<b>251</b>	300000	650000	
	438.14	1.7	<b>74</b>	373000	2.1	<b>86</b>	363000	3.3	<b>129</b>	338000	6.6	<b>233</b>	304000	650000	
	500.29	1.5	<b>66</b>	381000	1.8	<b>77</b>	370000	2.9	<b>116</b>	345000	5.8	<b>208</b>	310000	650000	
	562.28	1.3	<b>44.8</b>	290000	1.6	<b>52</b>	282000	2.6	<b>78</b>	262000	5.2	<b>141</b>	236000	526000	
	639.43	1.2	<b>40.2</b>	296000	1.4	<b>46.9</b>	288000	2.3	<b>70</b>	268000	4.5	<b>127</b>	241000	526000	
	699.14	1.1	<b>42.9</b>	345000	1.3	<b>50</b>	335000	2.1	<b>78</b>	326000	4.1	<b>151</b>	314000	650000	
	785.08	0.96	<b>33.8</b>	305000	1.1	<b>39.4</b>	297000	1.8	<b>59</b>	276000	3.7	<b>106</b>	249000	526000	
	897.23	0.84	<b>30.1</b>	311000	1.0	<b>35.2</b>	303000	1.6	<b>53</b>	282000	3.2	<b>95</b>	254000	526000	
1055.57	0.71	<b>26.3</b>	319000	0.9	<b>30.7</b>	310000	1.4	<b>45.9</b>	289000	2.7	<b>83</b>	260000	526000		
1252.76	0.60	<b>17.6</b>	253000	0.7	<b>20.5</b>	246000	1.2	<b>30.7</b>	229000	2.3	<b>55</b>	206000	420000		
GB 31005	719.53	1.04	<b>42.4</b>	342000	1.3	<b>49.4</b>	333000	2.0	<b>74</b>	309000	4.0	<b>133</b>	279000	549000	57 (H-F)
	858.53	0.87	<b>42.9</b>	413000	1.0	<b>50.1</b>	402000	1.7	<b>75</b>	374000	3.4	<b>135</b>	337000	650000	
	1001.04	0.75	<b>37.6</b>	423000	0.90	<b>43.9</b>	411000	1.4	<b>66</b>	383000	2.9	<b>119</b>	345000	650000	
	1101.78	0.68	<b>34.7</b>	429000	0.82	<b>40.5</b>	417000	1.3	<b>61</b>	388000	2.6	<b>109</b>	350000	650000	
	1254.09	0.60	<b>26.4</b>	372000	0.72	<b>30.9</b>	362000	1.2	<b>46.3</b>	337000	2.3	<b>83</b>	303000	549000	
	1403.42	0.53	<b>28.3</b>	445000	0.64	<b>33.0</b>	433000	1.0	<b>49.4</b>	403000	2.1	<b>89</b>	363000	650000	
	1577.29	0.48	<b>25.6</b>	453000	0.57	<b>29.9</b>	441000	0.92	<b>44.8</b>	410000	1.8	<b>81</b>	369000	650000	
	1784.27	0.42	<b>23.0</b>	461000	0.50	<b>20.1</b>	336000	0.81	<b>40.3</b>	418000	1.6	<b>73</b>	376000	650000	
	1981.09	0.38	<b>15.8</b>	351000	0.45	<b>18.4</b>	341000	0.73	<b>27.6</b>	318000	1.5	<b>50</b>	286000	526000	
	2239.08	0.33	<b>19.0</b>	478000	0.40	<b>22.2</b>	465000	0.65	<b>33.3</b>	432000	1.3	<b>60</b>	389000	650000	
	2516.91	0.30	<b>14.8</b>	419000	0.36	<b>17.3</b>	407000	0.58	<b>25.9</b>	379000	1.2	<b>46.7</b>	341000	650000	
	2811.38	0.27	<b>11.7</b>	370000	0.32	<b>13.7</b>	360000	0.52	<b>20.5</b>	335000	1.0	<b>37.0</b>	301000	526000	
	3148.70	0.24	<b>14.2</b>	503000	0.29	<b>16.6</b>	489000	0.46	<b>24.9</b>	455000	0.92	<b>44.8</b>	410000	650000	
	3559.02	0.21	<b>9.6</b>	383000	0.25	<b>11.2</b>	373000	0.41	<b>16.8</b>	347000	0.81	<b>30.3</b>	312000	526000	

	ie	n <sub>1</sub> = 750 RPM			n <sub>1</sub> = 900 RPM			n <sub>1</sub> = 1450 RPM			n <sub>1</sub> = 2900 RPM			T <sub>2max</sub> [Nm]	P <sub>t</sub> [kW]
		n <sub>2</sub> [RPM]	P <sub>1</sub> [kW]	T <sub>2</sub> [Nm]	n <sub>2</sub> [RPM]	P <sub>1</sub> [kW]	T <sub>2</sub> [Nm]	n <sub>2</sub> [RPM]	P <sub>1</sub> [kW]	T <sub>2</sub> [Nm]	n <sub>2</sub> [RPM]	P <sub>1</sub> [kW]	T <sub>2</sub> [Nm]		
<b>GBA 31004</b>	<b>172.32</b>	4.4	<b>112</b>	219000	5.2	<b>127</b>	207000	8.4	<b>178</b>	180000	16.8	<b>289</b>	146000	549000	60 (H-F)
	<b>205.61</b>	3.6	<b>112</b>	261000	4.4	<b>127</b>	247000	7.1	<b>178</b>	214000	14.1	<b>289</b>	174000	650000	
	<b>221.14</b>	3.4	<b>112</b>	281000	4.1	<b>127</b>	266000	6.6	<b>178</b>	231000	13.1	<b>289</b>	187000	549000	
	<b>263.86</b>	2.8	<b>112</b>	335000	3.4	<b>127</b>	317000	5.5	<b>178</b>	275000	11.0	<b>289</b>	223000	526000	
	<b>310.43</b>	2.4	<b>101</b>	354000	2.9	<b>118</b>	344000	4.7	<b>176</b>	321000	9.3	<b>289</b>	263000	526000	
	<b>368.42</b>	2.0	<b>78</b>	327000	2.4	<b>93</b>	323000	3.9	<b>146</b>	314000	7.9	<b>274</b>	296000	650000	
	<b>398.38</b>	1.9	<b>61</b>	275000	2.3	<b>71</b>	268000	3.6	<b>107</b>	249000	7.3	<b>194</b>	227000	549000	
	<b>469.14</b>	1.6	<b>53</b>	280000	1.9	<b>63</b>	277000	3.1	<b>98</b>	270000	6.2	<b>189</b>	259000	549000	
	<b>514.50</b>	1.5	<b>49</b>	286000	1.7	<b>57</b>	278000	2.8	<b>86</b>	259000	5.6	<b>155</b>	233000	526000	
	<b>561.13</b>	1.3	<b>35</b>	224000	1.6	<b>41</b>	218000	2.6	<b>62</b>	203000	5.2	<b>111</b>	183000	420000	
	<b>610.62</b>	1.2	<b>42</b>	294000	1.5	<b>50</b>	286000	2.4	<b>74</b>	266000	4.7	<b>134</b>	239000	526000	
	<b>718.37</b>	1.0	<b>37</b>	301000	1.3	<b>43</b>	293000	2.0	<b>65</b>	272000	4.0	<b>117</b>	245000	526000	
	<b>852.57</b>	0.88	<b>25</b>	239000	1.1	<b>29</b>	232000	1.7	<b>43</b>	216000	3.4	<b>78</b>	195000	549000	
<b>GBA 31005</b>	<b>584.24</b>	1.3	<b>51</b>	331000	1.5	<b>60</b>	322000	2.5	<b>90</b>	300000	5.0	<b>162</b>	270000	650000	50 (H-F)
	<b>697.10</b>	1.1	<b>52</b>	400000	1.3	<b>61</b>	389000	2.1	<b>91</b>	362000	4.2	<b>164</b>	326000	650000	
	<b>812.81</b>	0.92	<b>45.6</b>	410000	1.1	<b>53</b>	398000	1.8	<b>80</b>	371000	3.6	<b>144</b>	334000	420000	
	<b>894.61</b>	0.84	<b>42.1</b>	416000	1.0	<b>49.1</b>	404000	1.6	<b>74</b>	376000	3.2	<b>133</b>	339000	650000	
	<b>997.95</b>	0.75	<b>38.3</b>	423000	0.90	<b>44.7</b>	411000	1.5	<b>67</b>	382000	2.9	<b>121</b>	344000	650000	
	<b>1122.27</b>	0.67	<b>34.7</b>	430000	0.80	<b>40.5</b>	418000	1.3	<b>61</b>	389000	2.6	<b>109</b>	351000	650000	
	<b>1262.77</b>	0.59	<b>26.7</b>	372000	0.71	<b>31.2</b>	362000	1.1	<b>46.7</b>	337000	2.3	<b>84</b>	303000	549000	
	<b>1427.41</b>	0.53	<b>28.3</b>	446000	0.63	<b>33.0</b>	434000	1.0	<b>37.0</b>	302000	2.0	<b>89</b>	364000	650000	
	<b>1578.57</b>	0.48	<b>26.0</b>	453000	0.57	<b>30.3</b>	441000	0.92	<b>45.4</b>	410000	1.8	<b>82</b>	369000	650000	
	<b>1788.19</b>	0.42	<b>20.1</b>	397000	0.50	<b>23.5</b>	387000	0.81	<b>35.2</b>	360000	1.6	<b>65</b>	331000	650000	
	<b>2001.18</b>	0.37	<b>21.2</b>	469000	0.45	<b>18.6</b>	342000	0.72	<b>37.2</b>	425000	1.4	<b>67</b>	383000	650000	
	<b>2227.34</b>	0.34	<b>14.5</b>	357000	0.40	<b>16.9</b>	347000	0.65	<b>25.4</b>	323000	1.3	<b>45.7</b>	291000	526000	
	<b>2557.72</b>	0.29	<b>12.9</b>	365000	0.35	<b>15.1</b>	355000	0.57	<b>22.6</b>	330000	1.1	<b>40.7</b>	297000	526000	
	<b>2796.56</b>	0.27	<b>13.8</b>	425000	0.32	<b>16.1</b>	414000	0.52	<b>24.1</b>	385000	1.0	<b>43.4</b>	347000	650000	
	<b>3140.31</b>	0.24	<b>10.8</b>	376000	0.29	<b>12.7</b>	366000	0.46	<b>19.0</b>	340000	0.92	<b>34.2</b>	307000	526000	
	<b>3557.65</b>	0.21	<b>9.8</b>	383000	0.25	<b>11.4</b>	373000	0.41	<b>17.1</b>	347000	0.82	<b>30.7</b>	312000	526000	
	<b>4222.26</b>	0.18	<b>8.4</b>	393000	0.21	<b>9.8</b>	383000	0.34	<b>14.8</b>	356000	0.69	<b>26.6</b>	321000	526000	
<b>5011.04</b>	0.15	<b>5.6</b>	312000	0.18	<b>6.6</b>	304000	0.29	<b>9.9</b>	283000	0.58	<b>17.8</b>	255000	420000		

	ie	n <sub>1</sub> = 750 RPM			n <sub>1</sub> = 900 RPM			n <sub>1</sub> = 1450 RPM			n <sub>1</sub> = 2900 RPM			T <sub>2max</sub> [Nm]	P <sub>t</sub> [kW]
		n <sub>2</sub> [RPM]	P <sub>1</sub> [kW]	T <sub>2</sub> [Nm]	n <sub>2</sub> [RPM]	P <sub>1</sub> [kW]	T <sub>2</sub> [Nm]	n <sub>2</sub> [RPM]	P <sub>1</sub> [kW]	T <sub>2</sub> [Nm]	n <sub>2</sub> [RPM]	P <sub>1</sub> [kW]	T <sub>2</sub> [Nm]		
<b>GB 40001</b>	<b>3.43</b>	219	<b>3905</b>	166000	263	<b>4436</b>	157000	—	—	—	—	—	—	650000	224 (H-F)
	<b>4.09</b>	183	<b>3412</b>	173000	220	<b>3876</b>	164000	—	—	—	—	—	—	650000	
	<b>5.25</b>	143	<b>2782</b>	181000	171	<b>3160</b>	172000	—	—	—	—	—	—	650000	
	<b>6.23</b>	120	<b>2436</b>	188000	144	<b>2768</b>	178000	—	—	—	—	—	—	522000	
<b>GB 40002</b>	<b>14.03</b>	53	<b>1425</b>	242000	64	<b>1619</b>	229000	103	<b>2260</b>	198000	—	—	—	650000	130 (H-F)
	<b>16.74</b>	44.8	<b>1305</b>	264000	54	<b>1483</b>	250000	87	<b>2071</b>	217000	—	—	—	650000	
	<b>18.00</b>	41.7	<b>1161</b>	253000	50	<b>1319</b>	239000	81	<b>1842</b>	208000	—	—	—	650000	
	<b>21.48</b>	34.9	<b>1096</b>	285000	41.9	<b>1245</b>	270000	68	<b>1739</b>	234000	—	—	—	650000	
	<b>25.49</b>	29.4	<b>909</b>	280000	35.3	<b>1079</b>	277000	57	<b>1542</b>	246000	—	—	—	650000	
	<b>27.56</b>	27.2	<b>783</b>	261000	32.7	<b>930</b>	258000	53	<b>1418</b>	245000	—	—	—	650000	
	<b>32.71</b>	22.9	<b>666</b>	264000	27.5	<b>791</b>	261000	44.3	<b>1240</b>	254000	—	—	—	650000	
	<b>38.82</b>	19.3	<b>447</b>	210000	23.2	<b>531</b>	208000	37.3	<b>832</b>	202000	—	—	—	522000	
<b>GB 40003</b>	<b>56.10</b>	13.4	<b>413</b>	273000	16.0	<b>469</b>	259000	25.8	<b>655</b>	224000	52	<b>1064</b>	182000	650000	76 (H-F)
	<b>66.94</b>	11.2	<b>413</b>	326000	13.4	<b>469</b>	309000	21.7	<b>655</b>	268000	43.3	<b>1064</b>	217000	650000	
	<b>72.00</b>	10.4	<b>352</b>	300000	12.5	<b>415</b>	294000	20.1	<b>650</b>	286000	40.3	<b>1064</b>	234000	650000	
	<b>78.76</b>	9.5	<b>361</b>	336000	11.4	<b>411</b>	318000	18.4	<b>573</b>	276000	36.8	<b>932</b>	224000	650000	
	<b>85.91</b>	8.7	<b>357</b>	362000	10.5	<b>423</b>	358000	16.9	<b>655</b>	343000	33.8	<b>1064</b>	279000	650000	
	<b>101.07</b>	7.4	<b>311</b>	371000	8.9	<b>363</b>	361000	14.3	<b>569</b>	351000	28.7	<b>932</b>	287000	650000	
	<b>110.25</b>	6.8	<b>217</b>	283000	8.2	<b>258</b>	280000	13.2	<b>404</b>	272000	26.3	<b>778</b>	262000	650000	
	<b>129.71</b>	5.8	<b>189</b>	289000	6.9	<b>221</b>	282000	11.2	<b>347</b>	275000	22.4	<b>667</b>	264000	650000	
	<b>155.29</b>	4.8	<b>125</b>	229000	5.8	<b>147</b>	225000	9.3	<b>231</b>	219000	18.7	<b>444</b>	211000	522000	
	<b>182.69</b>	4.1	<b>109</b>	235000	4.9	<b>127</b>	229000	7.9	<b>198</b>	221000	15.9	<b>381</b>	212000	522000	
<b>GB 40004</b>	<b>199.87</b>	3.8	<b>140</b>	323000	4.5	<b>159</b>	305000	7.3	<b>223</b>	265000	14.5	<b>362</b>	215000	650000	72 (H-F)
	<b>235.14</b>	3.2	<b>132</b>	358000	3.8	<b>155</b>	348000	6.2	<b>223</b>	311000	12.3	<b>362</b>	253000	650000	
	<b>256.50</b>	2.9	<b>114</b>	338000	3.5	<b>136</b>	334000	5.7	<b>213</b>	325000	11.3	<b>362</b>	276000	650000	
	<b>280.57</b>	2.7	<b>134</b>	433000	3.2	<b>157</b>	421000	5.2	<b>223</b>	372000	10.3	<b>362</b>	302000	650000	
	<b>306.05</b>	2.5	<b>93</b>	329000	2.9	<b>109</b>	320000	4.7	<b>163</b>	297000	9.5	<b>362</b>	329000	650000	
	<b>351.86</b>	2.1	<b>85</b>	344000	2.6	<b>101</b>	341000	4.1	<b>158</b>	331000	8.2	<b>296</b>	310000	650000	
	<b>401.65</b>	1.9	<b>99</b>	457000	2.2	<b>116</b>	445000	3.6	<b>166</b>	398000	7.2	<b>270</b>	323000	650000	
	<b>438.14</b>	1.7	<b>82</b>	412000	2.1	<b>97</b>	407000	3.3	<b>152</b>	396000	6.6	<b>270</b>	353000	650000	
	<b>500.29</b>	1.5	<b>72</b>	417000	1.8	<b>86</b>	410000	2.9	<b>134</b>	399000	5.8	<b>244</b>	363000	650000	
	<b>562.28</b>	1.3	<b>56</b>	360000	1.6	<b>65</b>	351000	2.6	<b>97</b>	326000	5.2	<b>175</b>	294000	650000	
	<b>639.43</b>	1.2	<b>49.9</b>	367000	1.4	<b>58</b>	357000	2.3	<b>87</b>	333000	4.5	<b>157</b>	299000	650000	
	<b>699.14</b>	1.1	<b>42.9</b>	345000	1.3	<b>50</b>	335000	2.1	<b>78</b>	326000	4.1	<b>151</b>	314000	650000	
	<b>791.98</b>	0.95	<b>32.2</b>	294000	1.1	<b>37.6</b>	286000	1.8	<b>56</b>	266000	3.7	<b>102</b>	239000	522000	
	<b>889.41</b>	0.84	<b>37.7</b>	386000	1.0	<b>44.1</b>	376000	1.6	<b>66</b>	350000	3.3	<b>119</b>	315000	650000	
	<b>1055.57</b>	0.71	<b>32.6</b>	396000	0.85	<b>38.1</b>	386000	1.4	<b>57</b>	359000	2.7	<b>103</b>	323000	650000	
<b>GB 40005</b>	<b>719.53</b>	1.0	<b>52.6</b>	424000	1.25	<b>61.4</b>	413000	2.0	<b>92</b>	384000	4.0	<b>151</b>	316000	650000	59 (H-F)
	<b>858.53</b>	0.87	<b>53.3</b>	513000	1.05	<b>62.2</b>	499000	1.7	<b>93</b>	464000	3.4	<b>151</b>	377000	650000	
	<b>999.35</b>	0.75	<b>37.5</b>	421000	0.90	<b>44.6</b>	417000	1.5	<b>70</b>	404000	2.9	<b>125</b>	363000	650000	
	<b>1101.78</b>	0.68	<b>38.0</b>	470000	0.82	<b>44.4</b>	457000	1.3	<b>67</b>	425000	2.6	<b>126</b>	402000	650000	
	<b>1254.09</b>	0.60	<b>30.3</b>	426000	0.72	<b>36.0</b>	422000	1.2	<b>56</b>	411000	2.3	<b>103</b>	376000	650000	
	<b>1413.96</b>	0.53	<b>26.1</b>	414000	0.64	<b>30.5</b>	403000	1.0	<b>45.7</b>	375000	2.1	<b>82</b>	338000	650000	
	<b>1577.29</b>	0.48	<b>28.0</b>	496000	0.57	<b>32.7</b>	483000	0.92	<b>49.1</b>	449000	1.8	<b>90</b>	410000	650000	
	<b>1784.27</b>	0.42	<b>25.3</b>	506000	0.50	<b>29.5</b>	492000	0.81	<b>44.2</b>	458000	1.6	<b>80</b>	413000	650000	
	<b>1981.09</b>	0.38	<b>19.6</b>	436000	0.45	<b>22.9</b>	424000	0.73	<b>34.3</b>	395000	1.5	<b>62</b>	355000	650000	
	<b>2239.08</b>	0.33	<b>20.8</b>	520000	0.40	<b>24.3</b>	509000	0.65	<b>36.5</b>	474000	1.3	<b>66</b>	427000	650000	
	<b>2514.73</b>	0.30	<b>14.8</b>	419000	0.36	<b>17.3</b>	407000	0.58	<b>26.0</b>	379000	1.2	<b>46.7</b>	341000	650000	
	<b>2811.38</b>	0.27	<b>14.6</b>	460000	0.32	<b>17.0</b>	447000	0.52	<b>25.5</b>	416000	1.0	<b>45.9</b>	375000	650000	
	<b>3166.70</b>	0.24	<b>12.2</b>	433000	0.28	<b>14.2</b>	422000	0.46	<b>21.3</b>	392000	0.92	<b>38.4</b>	353000	650000	
	<b>3559.02</b>	0.21	<b>11.9</b>	476000	0.25	<b>13.9</b>	463000	0.41	<b>20.9</b>	431000	0.81	<b>37.6</b>	388000	650000	

	ie	n <sub>1</sub> = 750 RPM			n <sub>1</sub> = 900 RPM			n <sub>1</sub> = 1450 RPM			n <sub>1</sub> = 2900 RPM			T <sub>2max</sub> [Nm]	P <sub>t</sub> [kW]
		n <sub>2</sub> [RPM]	P <sub>1</sub> [kW]	T <sub>2</sub> [Nm]	n <sub>2</sub> [RPM]	P <sub>1</sub> [kW]	T <sub>2</sub> [Nm]	n <sub>2</sub> [RPM]	P <sub>1</sub> [kW]	T <sub>2</sub> [Nm]	n <sub>2</sub> [RPM]	P <sub>1</sub> [kW]	T <sub>2</sub> [Nm]		
<b>GBA 40004</b>	<b>172.32</b>	4.4	<b>112</b>	219000	5.2	<b>127</b>	207000	8.4	<b>178</b>	180000	16.8	<b>289</b>	146000	650000	62 (H-F)
	<b>205.61</b>	3.6	<b>112</b>	261000	4.4	<b>127</b>	247000	7.1	<b>178</b>	214000	14.1	<b>289</b>	174000	650000	
	<b>221.14</b>	3.4	<b>112</b>	281000	4.1	<b>127</b>	266000	6.6	<b>178</b>	231000	13.1	<b>289</b>	187000	650000	
	<b>260.17</b>	2.9	<b>112</b>	331000	3.5	<b>127</b>	313000	5.6	<b>178</b>	271000	11.1	<b>289</b>	220000	650000	
	<b>310.43</b>	2.4	<b>112</b>	394000	2.9	<b>127</b>	373000	4.7	<b>178</b>	324000	9.3	<b>289</b>	263000	650000	
	<b>368.42</b>	2.0	<b>78</b>	327000	2.4	<b>93</b>	323000	3.9	<b>146</b>	314000	7.9	<b>280</b>	302000	650000	
	<b>398.38</b>	1.9	<b>76</b>	342000	2.3	<b>88</b>	333000	3.6	<b>133</b>	310000	7.3	<b>241</b>	282000	650000	
	<b>469.14</b>	1.6	<b>53</b>	280000	1.9	<b>63</b>	277000	3.1	<b>98</b>	270000	6.2	<b>189</b>	259000	648000	
	<b>514.50</b>	1.5	<b>57</b>	330000	1.7	<b>67</b>	327000	2.8	<b>105</b>	318000	5.6	<b>192</b>	290000	650000	
	<b>559.77</b>	1.3	<b>53</b>	334000	1.6	<b>63</b>	331000	2.6	<b>98</b>	322000	5.2	<b>189</b>	310000	650000	
	<b>610.62</b>	1.2	<b>53</b>	365000	1.5	<b>62</b>	355000	2.4	<b>92</b>	330000	4.7	<b>166</b>	297000	650000	
	<b>718.37</b>	1.0	<b>45.9</b>	374000	1.3	<b>54</b>	364000	2.0	<b>80</b>	338000	4.0	<b>145</b>	305000	650000	
	<b>852.57</b>	0.88	<b>30.7</b>	297000	1.1	<b>35.9</b>	289000	1.7	<b>54</b>	269000	3.4	<b>97</b>	242000	522000	
<b>GBA 40005</b>	<b>584.24</b>	1.3	<b>64</b>	411000	1.5	<b>74</b>	400000	2.5	<b>109</b>	365000	5.0	<b>178</b>	297000	650000	54 (H-F)
	<b>697.10</b>	1.1	<b>65</b>	497000	1.3	<b>75</b>	484000	2.1	<b>109</b>	436000	4.2	<b>178</b>	354000	650000	
	<b>799.48</b>	0.94	<b>48.8</b>	431000	1.1	<b>57</b>	419000	1.8	<b>85</b>	390000	3.6	<b>143</b>	326000	650000	
	<b>894.61</b>	0.84	<b>46.1</b>	456000	1.0	<b>54</b>	443000	1.6	<b>81</b>	413000	3.2	<b>155</b>	397000	650000	
	<b>997.95</b>	0.75	<b>47.6</b>	520000	0.90	<b>56</b>	511000	1.5	<b>82</b>	467000	2.9	<b>133</b>	379000	650000	
	<b>1122.27</b>	0.67	<b>40.4</b>	501000	0.80	<b>48.0</b>	495000	1.3	<b>75</b>	482000	2.6	<b>136</b>	435000	650000	
	<b>1262.77</b>	0.59	<b>29.6</b>	413000	0.71	<b>34.6</b>	402000	1.1	<b>52</b>	374000	2.3	<b>95</b>	343000	650000	
	<b>1427.41</b>	0.53	<b>31.0</b>	489000	0.63	<b>36.2</b>	476000	1.0	<b>54</b>	442000	2.0	<b>100</b>	408000	650000	
	<b>1578.57</b>	0.48	<b>26.1</b>	456000	0.57	<b>31.0</b>	451000	0.92	<b>48.6</b>	439000	1.8	<b>94</b>	422000	650000	
	<b>1788.19</b>	0.42	<b>20.1</b>	397000	0.50	<b>19.6</b>	323000	0.81	<b>35.2</b>	360000	1.6	<b>65</b>	331000	650000	
	<b>1993.03</b>	0.38	<b>18.4</b>	404000	0.45	<b>21.4</b>	393000	0.73	<b>32.1</b>	366000	1.5	<b>58</b>	333000	650000	
	<b>2227.34</b>	0.34	<b>18.0</b>	444000	0.40	<b>21.1</b>	432000	0.65	<b>31.6</b>	402000	1.3	<b>57</b>	362000	650000	
	<b>2557.72</b>	0.29	<b>16.0</b>	453000	0.35	<b>18.7</b>	441000	0.57	<b>28.1</b>	410000	1.1	<b>51</b>	369000	650000	
	<b>2796.56</b>	0.27	<b>13.8</b>	425000	0.32	<b>16.1</b>	414000	0.52	<b>24.1</b>	385000	1.0	<b>43.4</b>	347000	650000	
	<b>3140.31</b>	0.24	<b>13.5</b>	467000	0.29	<b>15.7</b>	455000	0.46	<b>23.6</b>	423000	0.92	<b>42.5</b>	381000	650000	
	<b>3557.65</b>	0.21	<b>12.1</b>	476000	0.25	<b>14.1</b>	463000	0.41	<b>21.2</b>	431000	0.82	<b>38.2</b>	388000	650000	
	<b>4222.26</b>	0.18	<b>10.5</b>	489000	0.21	<b>12.2</b>	476000	0.34	<b>18.3</b>	442000	0.69	<b>33.0</b>	398000	650000	
<b>5011.04</b>	0.15	<b>7.0</b>	388000	0.18	<b>8.2</b>	378000	0.29	<b>12.3</b>	351000	0.58	<b>22.1</b>	316000	522000		

	ie	n <sub>1</sub> = 750 RPM			n <sub>1</sub> = 900 RPM			n <sub>1</sub> = 1450 RPM			n <sub>1</sub> = 2900 RPM			T <sub>2max</sub> [Nm]	P <sub>t</sub> [kW]
		n <sub>2</sub> [RPM]	P <sub>1</sub> [kW]	T <sub>2</sub> [Nm]	n <sub>2</sub> [RPM]	P <sub>1</sub> [kW]	T <sub>2</sub> [Nm]	n <sub>2</sub> [RPM]	P <sub>1</sub> [kW]	T <sub>2</sub> [Nm]	n <sub>2</sub> [RPM]	P <sub>1</sub> [kW]	T <sub>2</sub> [Nm]		
<b>GB 45001</b>	<b>3.83</b>	196	<b>4792</b>	228000	235	<b>5444</b>	216000	—	—	—	—	—	—	650000	224 (H-F)
<b>GB 45002</b>	<b>14.69</b>	51	<b>1919</b>	341000	61	<b>2180</b>	323000	99	<b>3044</b>	280000	—	—	—	650000	133 (H-F)
	<b>16.87</b>	44.5	<b>1742</b>	356000	53	<b>1979</b>	337000	86	<b>2764</b>	292000	—	—	—	650000	
<b>GB 45003</b>	<b>56.43</b>	13.3	<b>632</b>	421000	15.9	<b>718</b>	399000	25.7	<b>1003</b>	345000	—	—	—	650000	98 (H-F)
	<b>64.77</b>	11.6	<b>594</b>	454000	13.9	<b>705</b>	449000	22.4	<b>1003</b>	397000	—	—	—	650000	
	<b>76.07</b>	9.9	<b>495</b>	444000	11.8	<b>562</b>	421000	19.1	<b>785</b>	365000	—	—	—	650000	
	<b>87.31</b>	8.6	<b>448</b>	462000	10.3	<b>532</b>	457000	16.6	<b>785</b>	418000	—	—	—	650000	
<b>GB 45004</b>	<b>193.46</b>	3.9	<b>231</b>	513000	4.7	<b>269</b>	499000	7.5	<b>380</b>	437000	—	—	—	650000	76 (H-F)
	<b>222.06</b>	3.4	<b>205</b>	520000	4.1	<b>239</b>	510000	6.5	<b>359</b>	474000	—	—	—	650000	
	<b>260.80</b>	2.9	<b>176</b>	520000	3.5	<b>209</b>	520000	5.6	<b>313</b>	486000	—	—	—	650000	
	<b>299.35</b>	2.5	<b>159</b>	520000	3.0	<b>186</b>	520000	4.8	<b>279</b>	496000	—	—	—	650000	
	<b>311.18</b>	2.4	<b>149</b>	520000	2.9	<b>177</b>	520000	4.7	<b>270</b>	499000	—	—	—	650000	
	<b>357.18</b>	2.1	<b>137</b>	520000	2.5	<b>160</b>	520000	4.1	<b>240</b>	510000	—	—	—	650000	
	<b>399.34</b>	1.9	<b>118</b>	520000	2.3	<b>140</b>	520000	3.6	<b>218</b>	518000	—	—	—	650000	
	<b>458.38</b>	1.6	<b>111</b>	520000	2.0	<b>129</b>	520000	3.2	<b>194</b>	520000	—	—	—	650000	
	<b>544.01</b>	1.4	<b>96</b>	520000	1.7	<b>112</b>	520000	2.7	<b>168</b>	520000	—	—	—	650000	
<b>GB 45005</b>	<b>696.47</b>	1.1	<b>80</b>	520000	1.3	<b>93</b>	520000	2.1	<b>133</b>	520000	4.2	<b>217</b>	438000	650000	63 (H-F)
	<b>799.42</b>	0.94	<b>71</b>	520000	1.1	<b>83</b>	520000	1.8	<b>124</b>	520000	3.6	<b>217</b>	503000	650000	
	<b>981.05</b>	0.76	<b>60</b>	520000	0.92	<b>70</b>	520000	1.5	<b>104</b>	520000	3.0	<b>188</b>	520000	650000	
	<b>1126.08</b>	0.67	<b>53</b>	520000	0.80	<b>62</b>	520000	1.3	<b>93</b>	520000	2.6	<b>167</b>	520000	650000	
	<b>1259.02</b>	0.60	<b>48.0</b>	520000	0.71	<b>56</b>	520000	1.2	<b>84</b>	520000	2.3	<b>152</b>	520000	650000	
	<b>1413.12</b>	0.53	<b>43.7</b>	520000	0.64	<b>51</b>	520000	1.0	<b>77</b>	520000	2.1	<b>138</b>	520000	650000	
	<b>1579.95</b>	0.47	<b>38.8</b>	520000	0.57	<b>46.0</b>	520000	0.92	<b>70</b>	520000	1.8	<b>125</b>	520000	650000	
	<b>1813.50</b>	0.41	<b>35.4</b>	520000	0.50	<b>41.3</b>	520000	0.80	<b>62</b>	520000	1.6	<b>112</b>	520000	650000	
	<b>1987.20</b>	0.38	<b>27.2</b>	520000	0.45	<b>32.3</b>	520000	0.73	<b>51</b>	520000	1.5	<b>97</b>	520000	650000	
	<b>2245.11</b>	0.33	<b>27.0</b>	520000	0.40	<b>32.0</b>	520000	0.65	<b>50</b>	520000	1.3	<b>93</b>	520000	650000	
	<b>2502.04</b>	0.30	<b>22.5</b>	520000	0.36	<b>26.7</b>	520000	0.58	<b>41.9</b>	520000	1.2	<b>81</b>	520000	650000	
	<b>2841.93</b>	0.26	<b>21.8</b>	520000	0.32	<b>25.6</b>	520000	0.51	<b>40.2</b>	520000	1.0	<b>76</b>	520000	650000	
	<b>3372.84</b>	0.22	<b>18.9</b>	520000	0.27	<b>22.0</b>	520000	0.43	<b>34.2</b>	520000	0.9	<b>66</b>	520000	650000	
	<b>3554.59</b>	0.21	<b>16.1</b>	520000	0.25	<b>18.7</b>	520000	0.41	<b>28.6</b>	520000	0.8	<b>55</b>	520000	650000	

	ie	n <sub>1</sub> = 750 RPM			n <sub>1</sub> = 900 RPM			n <sub>1</sub> = 1450 RPM			n <sub>1</sub> = 2900 RPM			T <sub>2max</sub> [Nm]	P <sub>t</sub> [kW]
		n <sub>2</sub> [RPM]	P <sub>1</sub> [kW]	T <sub>2</sub> [Nm]	n <sub>2</sub> [RPM]	P <sub>1</sub> [kW]	T <sub>2</sub> [Nm]	n <sub>2</sub> [RPM]	P <sub>1</sub> [kW]	T <sub>2</sub> [Nm]	n <sub>2</sub> [RPM]	P <sub>1</sub> [kW]	T <sub>2</sub> [Nm]		
<b>GBA 45004</b>	<b>210.50</b>	3.6	<b>218</b>	520000	4.3	<b>255</b>	506000	6.9	<b>382</b>	471000	13.8	<b>651</b>	401000	650000	66 (H-F)
	<b>247.21</b>	3.0	<b>188</b>	520000	3.6	<b>222</b>	518000	5.9	<b>333</b>	482000	11.7	<b>582</b>	422000	650000	
	<b>283.76</b>	2.6	<b>169</b>	520000	3.2	<b>198</b>	520000	5.1	<b>296</b>	492000	10.2	<b>550</b>	457000	650000	
<b>GBA 45005</b>	<b>594.21</b>	1.3	<b>93</b>	520000	1.5	<b>108</b>	520000	2.4	<b>162</b>	520000	4.9	<b>292</b>	496000	650000	57 (H-F)
	<b>709.00</b>	1.1	<b>80</b>	520000	1.3	<b>93</b>	520000	2.0	<b>140</b>	520000	4.1	<b>251</b>	509000	650000	
	<b>813.81</b>	0.92	<b>71</b>	520000	1.1	<b>83</b>	520000	1.8	<b>124</b>	520000	3.6	<b>224</b>	520000	650000	
	<b>902.83</b>	0.83	<b>58</b>	520000	1.0	<b>69</b>	520000	1.6	<b>108</b>	520000	3.2	<b>205</b>	520000	650000	
	<b>1036.29</b>	0.72	<b>58</b>	520000	0.87	<b>67</b>	520000	1.4	<b>101</b>	520000	2.8	<b>182</b>	520000	650000	
	<b>1097.04</b>	0.68	<b>54</b>	520000	0.82	<b>64</b>	520000	1.3	<b>96</b>	520000	2.6	<b>174</b>	520000	650000	
	<b>1236.48</b>	0.61	<b>49.8</b>	520000	0.73	<b>58</b>	520000	1.2	<b>87</b>	520000	2.3	<b>157</b>	520000	650000	
	<b>1407.87</b>	0.53	<b>42.5</b>	520000	0.64	<b>50</b>	520000	1.0	<b>78</b>	520000	2.1	<b>140</b>	520000	650000	
	<b>1586.82</b>	0.47	<b>40.3</b>	520000	0.57	<b>47.0</b>	520000	0.91	<b>70</b>	520000	1.8	<b>127</b>	520000	650000	
	<b>1670.88</b>	0.45	<b>36.2</b>	520000	0.54	<b>43.0</b>	520000	0.87	<b>67</b>	520000	1.7	<b>121</b>	520000	650000	
	<b>1883.25</b>	0.40	<b>29.9</b>	520000	0.48	<b>35.5</b>	520000	0.77	<b>56</b>	520000	1.5	<b>107</b>	520000	650000	
<b>2211.75</b>	0.34	<b>24.4</b>	520000	0.41	<b>29.0</b>	520000	0.66	<b>45.4</b>	520000	1.3	<b>87</b>	520000	650000		

	ie	n <sub>1</sub> = 750 RPM			n <sub>1</sub> = 900 RPM			n <sub>1</sub> = 1450 RPM			n <sub>1</sub> = 2900 RPM			T <sub>2max</sub> [Nm]	P <sub>t</sub> [kW]
		n <sub>2</sub> [RPM]	P <sub>1</sub> [kW]	T <sub>2</sub> [Nm]	n <sub>2</sub> [RPM]	P <sub>1</sub> [kW]	T <sub>2</sub> [Nm]	n <sub>2</sub> [RPM]	P <sub>1</sub> [kW]	T <sub>2</sub> [Nm]	n <sub>2</sub> [RPM]	P <sub>1</sub> [kW]	T <sub>2</sub> [Nm]		
<b>GB 53001</b>	<b>3.84</b>	195	<b>6576</b>	313000	234	<b>7471</b>	477000	—	—	—	—	—	—	1191000	324 (H-F)
	<b>5.44</b>	138	<b>4311</b>	291000	166	<b>5120</b>	288000	—	—	—	—	—	—	801000	
<b>GB 53002</b>	<b>14.13</b>	53	<b>2124</b>	363000	64	<b>2413</b>	514000	—	—	—	—	—	—	1191000	185 (H-F)
	<b>18.97</b>	39.5	<b>1669</b>	383000	47.4	<b>1896</b>	490000	—	—	—	—	—	—	1191000	
<b>GB 53003</b>	<b>111.31</b>	6.7	<b>263</b>	346000	8.1	<b>313</b>	342000	13.0	<b>490</b>	333000	—	—	—	801000	132 (H-F)
	<b>145.09</b>	5.2	<b>209</b>	357000	6.2	<b>244</b>	348000	10.0	<b>382</b>	338000	—	—	—	801000	
	<b>174.64</b>	4.3	<b>178</b>	368000	5.2	<b>208</b>	358000	8.3	<b>321</b>	342000	—	—	—	801000	
<b>GB 53004</b>	<b>200.72</b>	3.7	<b>239</b>	553000	4.5	<b>272</b>	523000	7.2	<b>380</b>	453000	—	—	—	1191000	103 (H-F)
	<b>400.62</b>	1.9	<b>137</b>	631000	2.2	<b>163</b>	625000	3.6	<b>250</b>	597000	—	—	—	1191000	
	<b>475.46</b>	1.6	<b>117</b>	638000	1.9	<b>138</b>	631000	3.0	<b>217</b>	614000	—	—	—	1191000	
	<b>647.49</b>	1.2	<b>83</b>	616000	1.4	<b>97</b>	600000	2.2	<b>151</b>	584000	—	—	—	1191000	
	<b>768.45</b>	0.98	<b>72</b>	632000	1.2	<b>83</b>	615000	1.9	<b>129</b>	589000	—	—	—	1191000	
<b>GB 53005</b>	<b>1437.38</b>	0.52	<b>43.1</b>	695000	0.63	<b>50</b>	676000	1.0	<b>75</b>	629000	2.0	<b>141</b>	587000	1191000	84 (H-F)
	<b>1639.22</b>	0.46	<b>38.8</b>	713000	0.55	<b>46.0</b>	706000	0.88	<b>72</b>	687000	1.8	<b>139</b>	660000	1191000	
	<b>1936.50</b>	0.39	<b>33.5</b>	727000	0.46	<b>39.1</b>	707000	0.75	<b>59</b>	658000	1.5	<b>106</b>	597000	1191000	
	<b>2341.28</b>	0.32	<b>27.2</b>	714000	0.38	<b>32.0</b>	701000	0.62	<b>50</b>	673000	1.2	<b>95</b>	647000	1191000	
	<b>2766.43</b>	0.27	<b>22.6</b>	701000	0.33	<b>26.8</b>	694000	0.52	<b>42.0</b>	675000	1.0	<b>78</b>	625000	1191000	
	<b>3143.67</b>	0.24	<b>22.2</b>	782000	0.29	<b>25.9</b>	761000	0.46	<b>38.8</b>	708000	0.9	<b>70</b>	638000	1191000	
	<b>3335.08</b>	0.22	<b>21.1</b>	789000	0.30	<b>24.6</b>	768000	0.43	<b>36.9</b>	715000	0.9	<b>66</b>	643000	1191000	
	<b>3673.37</b>	0.20	<b>18.8</b>	775000	0.25	<b>22.3</b>	767000	0.39	<b>34.0</b>	725000	0.8	<b>61</b>	653000	1191000	

	ie	n <sub>1</sub> = 750 RPM			n <sub>1</sub> = 900 RPM			n <sub>1</sub> = 1450 RPM			n <sub>1</sub> = 2900 RPM			T <sub>2max</sub> [Nm]	P <sub>t</sub> [kW]
		n <sub>2</sub> [RPM]	P <sub>1</sub> [kW]	T <sub>2</sub> [Nm]	n <sub>2</sub> [RPM]	P <sub>1</sub> [kW]	T <sub>2</sub> [Nm]	n <sub>2</sub> [RPM]	P <sub>1</sub> [kW]	T <sub>2</sub> [Nm]	n <sub>2</sub> [RPM]	P <sub>1</sub> [kW]	T <sub>2</sub> [Nm]		
<b>GBA 53004</b>	<b>190.27</b>	3.9	<b>245</b>	527000	4.7	<b>287</b>	515000	7.6	<b>401</b>	447000	15.2	<b>651</b>	363000	1191000	89 (H-F)
	<b>248.00</b>	3.0	<b>219</b>	614000	3.6	<b>255</b>	596000	5.8	<b>356</b>	517000	11.7	<b>578</b>	420000	1191000	
	<b>361.75</b>	2.1	<b>100</b>	410000	2.5	<b>117</b>	399000	4.0	<b>175</b>	372000	8.0	<b>323</b>	342000	801000	
	<b>471.53</b>	1.6	<b>80</b>	427000	1.9	<b>93</b>	416000	3.1	<b>140</b>	387000	6.2	<b>252</b>	348000	801000	
	<b>567.58</b>	1.3	<b>68</b>	439000	1.6	<b>80</b>	427000	2.6	<b>120</b>	398000	5.1	<b>215</b>	358000	801000	
<b>GBA 53005</b>	<b>616.50</b>	1.2	<b>114</b>	773000	1.5	<b>129</b>	733000	2.4	<b>180</b>	635000	4.7	<b>293</b>	516000	1191000	75 (H-F)
	<b>735.60</b>	1.0	<b>99</b>	804000	1.2	<b>112</b>	761000	2.0	<b>157</b>	659000	3.9	<b>255</b>	536000	1191000	
	<b>1117.65</b>	0.67	<b>58</b>	717000	0.81	<b>69</b>	710000	1.3	<b>108</b>	691000	2.6	<b>190</b>	607000	1191000	
	<b>1500.68</b>	0.50	<b>42.2</b>	700000	0.60	<b>49</b>	681000	1.0	<b>74</b>	633000	1.9	<b>137</b>	589000	1191000	
	<b>2360.24</b>	0.32	<b>26.6</b>	695000	0.38	<b>32</b>	687000	0.61	<b>50</b>	669000	1.2	<b>91</b>	611000	1191000	
	<b>2979.23</b>	0.25	<b>23.6</b>	776000	0.30	<b>28</b>	755000	0.49	<b>41</b>	702000	1.0	<b>74</b>	632000	1191000	
	<b>3334.03</b>	0.22	<b>15.6</b>	574000	0.27	<b>18.2</b>	559000	0.43	<b>27</b>	520000	0.87	<b>49</b>	468000	801000	
	<b>3781.89</b>	0.20	<b>14.0</b>	585000	0.24	<b>16.4</b>	570000	0.38	<b>25</b>	530000	0.77	<b>44</b>	477000	801000	
	<b>4218.63</b>	0.18	<b>12.8</b>	595000	0.21	<b>14.9</b>	579000	0.34	<b>22</b>	539000	0.69	<b>40</b>	485000	801000	
	<b>5077.99</b>	0.15	<b>10.9</b>	612000	0.18	<b>12.7</b>	595000	0.29	<b>19</b>	554000	0.57	<b>34</b>	499000	801000	

	ie	n <sub>1</sub> = 750 RPM			n <sub>1</sub> = 900 RPM			n <sub>1</sub> = 1450 RPM			n <sub>1</sub> = 2900 RPM			T <sub>2max</sub> [Nm]	P <sub>t</sub> [kW]
		n <sub>2</sub> [RPM]	P <sub>1</sub> [kW]	T <sub>2</sub> [Nm]	n <sub>2</sub> [RPM]	P <sub>1</sub> [kW]	T <sub>2</sub> [Nm]	n <sub>2</sub> [RPM]	P <sub>1</sub> [kW]	T <sub>2</sub> [Nm]	n <sub>2</sub> [RPM]	P <sub>1</sub> [kW]	T <sub>2</sub> [Nm]		
<b>GB 61001</b>	<b>3.84</b>	195	<b>8767</b>	418000	—	—	—	—	—	—	—	—	—	1310000	324 (H-F)
<b>GB 61002</b>	<b>14.13</b>	53	<b>2124</b>	363000	64	<b>2413</b>	344000	—	—	—	—	—	—	1310000	185 (H-F)
	<b>18.97</b>	39.5	<b>1669</b>	383000	47.4	<b>1896</b>	363000	—	—	—	—	—	—	1310000	
<b>GB 61003</b>	<b>102.46</b>	7.3	<b>451</b>	546000	8.8	<b>536</b>	540000	14.2	<b>779</b>	487000	—	—	—	1310000	132 (H-F)
	<b>123.33</b>	6.1	<b>379</b>	551000	7.3	<b>450</b>	546000	11.8	<b>665</b>	501000	—	—	—	1310000	
<b>GB 61004</b>	<b>224.42</b>	3.3	<b>243</b>	627000	4.0	<b>276</b>	593000	6.5	<b>385</b>	514000	—	—	—	1310000	103 (H-F)
	<b>292.52</b>	2.6	<b>184</b>	620000	3.1	<b>219</b>	614000	5.0	<b>312</b>	543000	—	—	—	1310000	
	<b>307.35</b>	2.4	<b>195</b>	689000	2.9	<b>221</b>	652000	4.7	<b>309</b>	565000	—	—	—	1310000	
	<b>400.62</b>	1.9	<b>137</b>	631000	2.2	<b>163</b>	625000	3.6	<b>250</b>	597000	—	—	—	1310000	
	<b>537.92</b>	1.4	<b>97</b>	600000	1.7	<b>115</b>	594000	2.7	<b>180</b>	578000	—	—	—	1310000	
	<b>647.49</b>	1.2	<b>83</b>	616000	1.4	<b>97</b>	600000	2.2	<b>151</b>	584000	—	—	—	1310000	
<b>GB 61005</b>	<b>897.67</b>	0.84	<b>81</b>	816000	1.0	<b>96</b>	807000	1.6	<b>150</b>	780000	3.2	<b>243</b>	633000	1310000	84 (H-F)
	<b>1020.08</b>	0.74	<b>72</b>	822000	0.88	<b>85</b>	813000	1.4	<b>134</b>	791000	2.8	<b>222</b>	658000	1310000	
	<b>1170.06</b>	0.64	<b>51</b>	671000	0.77	<b>61</b>	664000	1.2	<b>95</b>	647000	2.5	<b>183</b>	621000	1310000	
	<b>1229.41</b>	0.61	<b>60</b>	833000	0.73	<b>72</b>	822000	1.2	<b>112</b>	800000	2.4	<b>195</b>	696000	1310000	
	<b>1397.06</b>	0.54	<b>54</b>	849000	0.64	<b>63</b>	828000	1.0	<b>99</b>	806000	2.1	<b>178</b>	723000	1310000	
	<b>1571.06</b>	0.48	<b>40.0</b>	704000	0.57	<b>46.7</b>	685000	0.92	<b>70</b>	638000	1.8	<b>129</b>	590000	1310000	
	<b>1785.29</b>	0.42	<b>35.9</b>	718000	0.50	<b>41.9</b>	699000	0.81	<b>63</b>	650000	1.6	<b>115</b>	595000	1310000	
	<b>1928.91</b>	0.39	<b>24.0</b>	520000	0.47	<b>28.5</b>	515000	0.75	<b>44.7</b>	501000	1.5	<b>86</b>	481000	1310000	
	<b>2151.66</b>	0.35	<b>30.6</b>	739000	0.42	<b>35.7</b>	719000	0.67	<b>53.6</b>	669000	1.3	<b>96</b>	602000	1310000	
	<b>2589.97</b>	0.29	<b>24.0</b>	698000	0.35	<b>28.5</b>	691000	0.56	<b>44.7</b>	672000	1.1	<b>82</b>	619000	1310000	
	<b>2943.14</b>	0.25	<b>21.4</b>	706000	0.31	<b>25.3</b>	696000	0.49	<b>39.7</b>	677000	1.0	<b>74</b>	631000	1310000	

	ie	n <sub>1</sub> = 750 RPM			n <sub>1</sub> = 900 RPM			n <sub>1</sub> = 1450 RPM			n <sub>1</sub> = 2900 RPM			T <sub>2max</sub> [Nm]	P <sub>t</sub> [kW]
		n <sub>2</sub> [RPM]	P <sub>1</sub> [kW]	T <sub>2</sub> [Nm]	n <sub>2</sub> [RPM]	P <sub>1</sub> [kW]	T <sub>2</sub> [Nm]	n <sub>2</sub> [RPM]	P <sub>1</sub> [kW]	T <sub>2</sub> [Nm]	n <sub>2</sub> [RPM]	P <sub>1</sub> [kW]	T <sub>2</sub> [Nm]		
<b>GBA 61004</b>	<b>190.27</b>	3.9	<b>245</b>	527000	4.7	<b>287</b>	515000	7.6	<b>401</b>	447000	15.2	<b>651</b>	363000	1310000	89 (H-F)
	<b>333.00</b>	2.3	<b>155</b>	584000	2.7	<b>184</b>	577000	4.4	<b>288</b>	562000	8.7	<b>554</b>	540000	1310000	
	<b>400.83</b>	1.9	<b>130</b>	590000	2.2	<b>154</b>	584000	3.6	<b>242</b>	568000	7.2	<b>465</b>	546000	1310000	
<b>GBA 61005</b>	<b>898.44</b>	0.83	<b>67</b>	661000	1.0	<b>79</b>	654000	1.6	<b>124</b>	637000	3.2	<b>238</b>	612000	1310000	75 (H-F)
	<b>944.01</b>	0.79	<b>78</b>	818000	1.0	<b>93</b>	810000	1.5	<b>146</b>	788000	3.1	<b>238</b>	643000	1310000	
	<b>1047.28</b>	0.72	<b>58</b>	672000	0.83	<b>69</b>	665000	1.3	<b>108</b>	647000	2.8	<b>206</b>	617000	1310000	
	<b>1230.47</b>	0.61	<b>49.5</b>	673000	0.71	<b>59</b>	666000	1.1	<b>92</b>	648000	2.4	<b>177</b>	623000	1310000	
	<b>1434.32</b>	0.52	<b>54</b>	852000	0.63	<b>63</b>	829000	1.0	<b>98</b>	807000	2.0	<b>178</b>	729000	1310000	
	<b>1652.17</b>	0.40	<b>38.9</b>	710000	0.54	<b>45.4</b>	691000	0.88	<b>68</b>	642000	1.8	<b>125</b>	592000	1310000	
	<b>1988.72</b>	0.38	<b>31.3</b>	688000	0.45	<b>37.2</b>	681000	0.73	<b>58</b>	661000	1.5	<b>105</b>	598000	1310000	
	<b>2206.27</b>	0.34	<b>28.4</b>	692000	0.41	<b>33.7</b>	685000	0.66	<b>53</b>	666000	1.3	<b>96</b>	604000	1310000	
	<b>2510.28</b>	0.30	<b>27.3</b>	756000	0.36	<b>31.8</b>	736000	0.58	<b>47.7</b>	684000	1.2	<b>85.9</b>	616000	1310000	
	<b>3021.63</b>	0.25	<b>21.2</b>	709000	0.30	<b>25.1</b>	697000	0.58	<b>39.3</b>	678000	0.96	<b>73.4</b>	634000	1310000	
<b>GBA 61006</b>	<b>3259.46</b>	0.23	<b>21.6</b>	758000	0.28	<b>24.6</b>	737000	0.44	<b>37.8</b>	686000	0.89	<b>72.6</b>	659000	1310000	63 (H-F)
	<b>3590.67</b>	0.21	<b>22.2</b>	858000	0.25	<b>25.2</b>	812000	0.40	<b>35.2</b>	704000	0.81	<b>57.2</b>	572000	1310000	
	<b>3923.43</b>	0.19	<b>13.6</b>	574000	0.23	<b>15.9</b>	559000	0.37	<b>23.9</b>	522000	0.74	<b>45.9</b>	501000	1310000	
	<b>4464.05</b>	0.17	<b>16.5</b>	795000	0.20	<b>19.3</b>	773000	0.32	<b>28.9</b>	719000	0.65	<b>54.0</b>	671000	1310000	
	<b>5072.78</b>	0.15	<b>14.8</b>	810000	0.18	<b>17.3</b>	788000	0.29	<b>25.9</b>	733000	0.57	<b>47.8</b>	676000	1310000	
	<b>5588.25</b>	0.13	<b>16.5</b>	994000	0.16	<b>19.6</b>	984000	0.26	<b>30.4</b>	948000	0.52	<b>54.8</b>	853000	1310000	
	<b>6284.23</b>	0.12	<b>12.8</b>	869000	0.14	<b>15.0</b>	845000	0.23	<b>22.5</b>	786000	0.46	<b>40.5</b>	708000	1310000	
	<b>7141.17</b>	0.11	<b>11.5</b>	886000	0.13	<b>13.4</b>	862000	0.20	<b>20.2</b>	802000	0.41	<b>36.3</b>	722000	1310000	
	<b>8198.76</b>	0.09	<b>9.3</b>	825000	0.11	<b>10.9</b>	802000	0.18	<b>16.3</b>	746000	0.35	<b>30.2</b>	690000	1310000	
	<b>8767.77</b>	0.09	<b>6.9</b>	649000	0.10	<b>8.0</b>	631000	0.17	<b>12.0</b>	587000	0.33	<b>21.6</b>	529000	1310000	
	<b>10359.87</b>	0.07	<b>7.7</b>	854000	0.09	<b>8.9</b>	831000	0.14	<b>13.4</b>	773000	0.28	<b>24.2</b>	700000	1310000	
	<b>11772.58</b>	0.06	<b>6.9</b>	871000	0.08	<b>8.0</b>	847000	0.12	<b>12.0</b>	788000	0.25	<b>21.6</b>	710000	1310000	

	ie	n <sub>1</sub> = 750 RPM			n <sub>1</sub> = 900 RPM			n <sub>1</sub> = 1450 RPM			n <sub>1</sub> = 2900 RPM			T <sub>2max</sub> [Nm]	P <sub>t</sub> [kW]
		n <sub>2</sub> [RPM]	P <sub>1</sub> [kW]	T <sub>2</sub> [Nm]	n <sub>2</sub> [RPM]	P <sub>1</sub> [kW]	T <sub>2</sub> [Nm]	n <sub>2</sub> [RPM]	P <sub>1</sub> [kW]	T <sub>2</sub> [Nm]	n <sub>2</sub> [RPM]	P <sub>1</sub> [kW]	T <sub>2</sub> [Nm]		
<b>GB 85001</b>	<b>3.84</b>	195	<b>10959</b>	522000	—	—	—	—	—	—	—	—	—	1310000	336 (H-F)
<b>GB 85002</b>	<b>14.13</b>	53	<b>2467</b>	422000	64	<b>2803</b>	400000	—	—	—	—	—	—	1310000	193 (H-F)
	<b>18.97</b>	39.5	<b>1938</b>	445000	47.4	<b>2202</b>	421000	—	—	—	—	—	—	1310000	
<b>GB 85003</b>	<b>56.52</b>	13.3	<b>830</b>	554000	15.9	<b>943</b>	524000	25.7	<b>1317</b>	455000	—	—	—	1310000	141 (H-F)
	<b>65.95</b>	11.4	<b>732</b>	570000	13.6	<b>832</b>	539000	22.0	<b>1161</b>	467000	—	—	—	1310000	
	<b>75.90</b>	9.9	<b>688</b>	616000	11.9	<b>817</b>	609000	19.1	<b>1195</b>	554000	—	—	—	1310000	
	<b>88.55</b>	8.5	<b>595</b>	621000	10.2	<b>706</b>	615000	16.4	<b>1073</b>	580000	—	—	—	1310000	
<b>GB 85004</b>	<b>226.10</b>	3.3	<b>323</b>	840000	4.0	<b>367</b>	795000	6.4	<b>512</b>	689000	12.8	<b>832</b>	560000	1310000	110 (H-F)
	<b>266.00</b>	2.8	<b>288</b>	882000	3.4	<b>327</b>	835000	5.5	<b>457</b>	723000	10.9	<b>742</b>	588000	1310000	
	<b>310.33</b>	2.4	<b>250</b>	894000	2.9	<b>288</b>	858000	4.7	<b>403</b>	744000	9.3	<b>654</b>	604000	1310000	
	<b>354.18</b>	2.1	<b>165</b>	673000	2.5	<b>196</b>	666000	4.1	<b>307</b>	648000	8.2	<b>591</b>	623000	1310000	
	<b>416.69</b>	1.8	<b>142</b>	679000	2.2	<b>168</b>	672000	3.5	<b>264</b>	654000	7.0	<b>507</b>	628000	1310000	
<b>GB 85005</b>	<b>805.48</b>	0.93	<b>112</b>	1015000	1.1	<b>131</b>	988000	1.8	<b>197</b>	919000	3.6	<b>351</b>	819000	1310000	91 (H-F)
	<b>947.62</b>	0.79	<b>98</b>	1041000	0.95	<b>114</b>	1012000	1.5	<b>171</b>	942000	3.1	<b>313</b>	860000	1310000	
	<b>1153.11</b>	0.65	<b>83</b>	1072000	0.78	<b>97</b>	1043000	1.3	<b>145</b>	970000	2.5	<b>267</b>	892000	1310000	
	<b>1261.05</b>	0.59	<b>55</b>	783000	0.71	<b>65</b>	761000	1.1	<b>97</b>	708000	2.3	<b>183</b>	669000	1310000	
	<b>1356.60</b>	0.55	<b>72</b>	1048000	0.66	<b>84</b>	1048000	1.1	<b>126</b>	994000	2.1	<b>229</b>	900000	1310000	
	<b>1582.69</b>	0.47	<b>59</b>	1048000	0.57	<b>70</b>	1041000	0.92	<b>110</b>	1013000	1.8	<b>200</b>	917000	1310000	
	<b>1767.94</b>	0.42	<b>41.5</b>	824000	0.51	<b>48.5</b>	801000	0.82	<b>73</b>	745000	1.6	<b>133</b>	682000	1310000	
	<b>2062.60</b>	0.36	<b>36.4</b>	843000	0.44	<b>42.5</b>	820000	0.70	<b>64</b>	763000	1.4	<b>115</b>	688000	1310000	
	<b>2449.10</b>	0.31	<b>31.5</b>	865000	0.37	<b>36.8</b>	842000	0.59	<b>55</b>	783000	1.2	<b>99</b>	705000	1310000	

	ie	n <sub>1</sub> = 750 RPM			n <sub>1</sub> = 900 RPM			n <sub>1</sub> = 1450 RPM			n <sub>1</sub> = 2900 RPM			T <sub>2max</sub> [Nm]	P <sub>t</sub> [kW]
		n <sub>2</sub> [RPM]	P <sub>1</sub> [kW]	T <sub>2</sub> [Nm]	n <sub>2</sub> [RPM]	P <sub>1</sub> [kW]	T <sub>2</sub> [Nm]	n <sub>2</sub> [RPM]	P <sub>1</sub> [kW]	T <sub>2</sub> [Nm]	n <sub>2</sub> [RPM]	P <sub>1</sub> [kW]	T <sub>2</sub> [Nm]		
<b>GBA 85004</b>	<b>214.32</b>	3.5	<b>245</b>	594000	4.2	<b>287</b>	580000	6.8	<b>401</b>	503000	13.5	<b>651</b>	409000	1310000	92 (H-F)
	<b>246.66</b>	3.0	<b>236</b>	659000	3.6	<b>280</b>	652000	5.9	<b>401</b>	579000	11.8	<b>651</b>	470000	1310000	
	<b>287.77</b>	2.6	<b>204</b>	665000	3.1	<b>242</b>	658000	5.0	<b>380</b>	640000	10.1	<b>651</b>	549000	1310000	
<b>GBA 85005</b>	<b>694.45</b>	1.1	<b>115</b>	882000	1.3	<b>131</b>	835000	2.1	<b>182</b>	724000	4.2	<b>296</b>	588000	1310000	79 (H-F)
	<b>810.19</b>	0.93	<b>113</b>	1012000	1.1	<b>131</b>	975000	1.8	<b>182</b>	845000	3.6	<b>296</b>	686000	1310000	
	<b>953.16</b>	0.79	<b>97</b>	1022000	0.94	<b>115</b>	1011000	1.5	<b>173</b>	943000	3.0	<b>296</b>	807000	1310000	
	<b>1096.99</b>	0.68	<b>63</b>	766000	0.82	<b>74</b>	745000	1.3	<b>111</b>	694000	2.6	<b>212</b>	664000	1310000	
	<b>1241.33</b>	0.60	<b>58</b>	797000	0.73	<b>69</b>	789000	1.2	<b>108</b>	767000	2.3	<b>206</b>	731000	1310000	
	<b>1448.22</b>	0.52	<b>58</b>	930000	0.62	<b>69</b>	920000	1.0	<b>108</b>	895000	2.0	<b>206</b>	853000	1310000	
	<b>1652.86</b>	0.45	<b>44.7</b>	815000	0.54	<b>52</b>	793000	0.88	<b>78</b>	738000	1.8	<b>144</b>	680000	1310000	
	<b>1944.54</b>	0.39	<b>38.9</b>	836000	0.46	<b>45.4</b>	813000	0.75	<b>68</b>	756000	1.7	<b>124</b>	686000	1310000	
<b>GBA 85006</b>	<b>2354.48</b>	0.32	<b>47.1</b>	1048000	0.38	<b>55.0</b>	1048000	0.62	<b>82</b>	1048000	1.5	<b>148</b>	973000	1310000	69 (H-F)
	<b>2745.30</b>	0.27	<b>41.3</b>	1048000	0.33	<b>48.3</b>	1048000	0.53	<b>72</b>	1048000	1.2	<b>130</b>	996000	1310000	
	<b>3202.85</b>	0.23	<b>33.4</b>	1048000	0.28	<b>39.0</b>	1048000	0.45	<b>59</b>	1048000	1.1	<b>114</b>	1014000	1310000	
	<b>3686.14</b>	0.20	<b>23.2</b>	920000	0.24	<b>27.1</b>	895000	0.39	<b>40.6</b>	833000	0.91	<b>73</b>	750000	1310000	
	<b>3965.43</b>	0.19	<b>30.3</b>	1048000	0.23	<b>35.3</b>	1048000	0.37	<b>52.9</b>	1048000	0.79	<b>95</b>	1048000	1310000	
	<b>4490.27</b>	0.17	<b>25.1</b>	1048000	0.20	<b>29.3</b>	1048000	0.32	<b>43.9</b>	1048000	0.65	<b>83</b>	1033000	1310000	
	<b>5156.29</b>	0.15	<b>22.3</b>	1048000	0.17	<b>26.0</b>	1048000	0.28	<b>39.0</b>	1048000	0.56	<b>73</b>	1042000	1310000	
	<b>5426.38</b>	0.14	<b>23.2</b>	1048000	0.17	<b>27.1</b>	1048000	0.27	<b>40.6</b>	1048000	0.53	<b>73</b>	1104000	1310000	
	<b>6330.78</b>	0.12	<b>18.7</b>	1048000	0.14	<b>21.9</b>	1048000	0.23	<b>32.8</b>	1048000	0.46	<b>60</b>	1048000	1310000	
	<b>7099.24</b>	0.11	<b>13.3</b>	1016000	0.13	<b>15.5</b>	989000	0.20	<b>23.3</b>	920000	0.41	<b>41.9</b>	828000	1310000	
	<b>8250.39</b>	0.09	<b>11.7</b>	1040000	0.11	<b>13.7</b>	1012000	0.18	<b>20.5</b>	941000	0.35	<b>36.9</b>	847000	1310000	
	<b>9796.38</b>	0.08	<b>10.1</b>	1048000	0.09	<b>11.8</b>	1038000	0.15	<b>17.7</b>	966000	0.30	<b>31.9</b>	870000	1310000	
	<b>11429.12</b>	0.07	<b>8.9</b>	1048000	0.08	<b>10.4</b>	1048000	0.13	<b>15.5</b>	989000	0.25	<b>28.0</b>	890000	1310000	

	ie	n <sub>1</sub> = 750 RPM			n <sub>1</sub> = 900 RPM			n <sub>1</sub> = 1450 RPM			n <sub>1</sub> = 2900 RPM			T <sub>2max</sub> [Nm]	P <sub>t</sub> [kW]
		n <sub>2</sub> [RPM]	P <sub>1</sub> [kW]	T <sub>2</sub> [Nm]	n <sub>2</sub> [RPM]	P <sub>1</sub> [kW]	T <sub>2</sub> [Nm]	n <sub>2</sub> [RPM]	P <sub>1</sub> [kW]	T <sub>2</sub> [Nm]	n <sub>2</sub> [RPM]	P <sub>1</sub> [kW]	T <sub>2</sub> [Nm]		
<b>GB 110001</b>	<b>4.32</b>	174	<b>10073</b>	540000	—	—	—	—	—	—	—	—	—	2250000	584 (H-F)
<b>GB 110002</b>	<b>14.81</b>	51	<b>4005</b>	718000	61	<b>4550</b>	680000	—	—	—	—	—	—	2250000	340 (H-F)
	<b>17.67</b>	42.4	<b>3499</b>	749000	51	<b>3976</b>	709000	—	—	—	—	—	—	2250000	
	<b>22.68</b>	33.1	<b>2853</b>	783000	39.7	<b>3241</b>	742000	—	—	—	—	—	—	2250000	
	<b>26.92</b>	27.9	<b>2499</b>	814000	33.4	<b>2839</b>	771000	—	—	—	—	—	—	2250000	
<b>GB 110003</b>	<b>60.59</b>	12.4	<b>1336</b>	955000	14.9	<b>1587</b>	945000	23.9	<b>2318</b>	857000	—	—	—	2250000	241 (H-F)
	<b>77.76</b>	9.6	<b>1056</b>	969000	11.6	<b>1254</b>	959000	18.6	<b>1889</b>	897000	—	—	—	2250000	
	<b>92.78</b>	8.1	<b>897</b>	982000	9.7	<b>1062</b>	969000	15.6	<b>1664</b>	943000	—	—	—	2250000	
	<b>110.11</b>	6.8	<b>776</b>	1008000	8.2	<b>905</b>	980000	13.2	<b>1416</b>	952000	—	—	—	2250000	
	<b>119.07</b>	6.3	<b>726</b>	1020000	7.6	<b>847</b>	992000	12.2	<b>1316</b>	956000	—	—	—	2250000	
	<b>141.31</b>	5.3	<b>628</b>	1047000	6.4	<b>733</b>	1018000	10.3	<b>1119</b>	966000	—	—	—	2250000	
	<b>167.71</b>	4.5	<b>459</b>	908000	5.4	<b>545</b>	898000	8.6	<b>854</b>	874000	—	—	—	2250000	
<b>GB 110004</b>	<b>242.37</b>	3.1	<b>407</b>	1136000	3.7	<b>475</b>	1105000	6.0	<b>672</b>	969000	12.0	<b>1091</b>	787000	2250000	186 (H-F)
	<b>289.19</b>	2.6	<b>351</b>	1166000	3.1	<b>409</b>	1135000	5.0	<b>613</b>	1056000	10.0	<b>1091</b>	939000	2250000	
	<b>311.04</b>	2.4	<b>330</b>	1179000	2.9	<b>385</b>	1147000	4.7	<b>577</b>	1067000	9.3	<b>1049</b>	971000	2250000	
	<b>365.93</b>	2.0	<b>287</b>	1209000	2.5	<b>335</b>	1176000	4.0	<b>502</b>	1094000	7.9	<b>905</b>	985000	2250000	
	<b>440.46</b>	1.7	<b>245</b>	1243000	2.0	<b>286</b>	1209000	3.3	<b>429</b>	1125000	6.6	<b>773</b>	1013000	2250000	
	<b>518.19</b>	1.4	<b>214</b>	1274000	1.7	<b>249</b>	1239000	2.8	<b>374</b>	1153000	5.6	<b>673</b>	1038000	2250000	
	<b>560.33</b>	1.3	<b>193</b>	1247000	1.6	<b>227</b>	1220000	2.6	<b>350</b>	1167000	5.2	<b>630</b>	1051000	2250000	
	<b>665.01</b>	1.1	<b>167</b>	1280000	1.4	<b>195</b>	1245000	2.2	<b>303</b>	1197000	4.4	<b>545</b>	1078000	2250000	
	<b>789.24</b>	0.95	<b>112</b>	1016000	1.1	<b>131</b>	988000	1.8	<b>203</b>	955000	3.7	<b>391</b>	918000	2250000	
<b>GB 110005</b>	<b>863.44</b>	0.87	<b>142</b>	1376000	1.0	<b>163</b>	1320000	1.7	<b>228</b>	1144000	3.4	<b>371</b>	929000	2250000	152 (H-F)
	<b>1015.81</b>	0.74	<b>124</b>	1411000	0.89	<b>144</b>	1372000	1.4	<b>217</b>	1277000	2.9	<b>371</b>	1093000	2250000	
	<b>1108.08</b>	0.68	<b>115</b>	1429000	0.81	<b>134</b>	1390000	1.3	<b>201</b>	1294000	2.6	<b>362</b>	1165000	2250000	
	<b>1236.08</b>	0.61	<b>105</b>	1453000	0.73	<b>122</b>	1413000	1.2	<b>171</b>	1225000	2.3	<b>277</b>	995000	2250000	
	<b>1413.24</b>	0.53	<b>94</b>	1483000	0.64	<b>109</b>	1442000	1.0	<b>164</b>	1342000	2.1	<b>295</b>	1208000	2250000	
	<b>1474.87</b>	0.51	<b>90</b>	1492000	0.61	<b>105</b>	1452000	0.98	<b>158</b>	1351000	2.0	<b>277</b>	1187000	2250000	
	<b>1586.30</b>	0.47	<b>84</b>	1490000	0.57	<b>99</b>	1468000	0.91	<b>148</b>	1366000	1.8	<b>267</b>	1230000	2250000	
	<b>1735.14</b>	0.43	<b>79</b>	1530000	0.52	<b>92</b>	1488000	0.84	<b>137</b>	1384000	1.7	<b>248</b>	1247000	2250000	
	<b>1996.17</b>	0.38	<b>67</b>	1511000	0.45	<b>79</b>	1470000	0.73	<b>118</b>	1368000	1.5	<b>213</b>	1231000	2250000	
	<b>2246.34</b>	0.33	<b>57</b>	1439000	0.40	<b>68</b>	1424000	0.65	<b>106</b>	1386000	1.3	<b>199</b>	1296000	2250000	
	<b>2509.23</b>	0.30	<b>56</b>	1587000	0.36	<b>66</b>	1544000	0.58	<b>101</b>	1464000	1.2	<b>181</b>	1318000	2250000	
	<b>2857.68</b>	0.26	<b>49.8</b>	1595000	0.31	<b>58</b>	1552000	0.51	<b>87</b>	1444000	1.0	<b>157</b>	1300000	2250000	
	<b>3263.09</b>	0.23	<b>44.5</b>	1628000	0.28	<b>52</b>	1583000	0.44	<b>78</b>	1473000	0.89	<b>140</b>	1327000	2250000	
	<b>3553.28</b>	0.21	<b>38.3</b>	1527000	0.25	<b>44.7</b>	1485000	0.41	<b>69</b>	1422000	0.82	<b>133</b>	1367000	2250000	

	ie	n <sub>1</sub> = 750 RPM			n <sub>1</sub> = 900 RPM			n <sub>1</sub> = 1450 RPM			n <sub>1</sub> = 2900 RPM			T <sub>2max</sub> [Nm]	P <sub>t</sub> [kW]
		n <sub>2</sub> [RPM]	P <sub>1</sub> [kW]	T <sub>2</sub> [Nm]	n <sub>2</sub> [RPM]	P <sub>1</sub> [kW]	T <sub>2</sub> [Nm]	n <sub>2</sub> [RPM]	P <sub>1</sub> [kW]	T <sub>2</sub> [Nm]	n <sub>2</sub> [RPM]	P <sub>1</sub> [kW]	T <sub>2</sub> [Nm]		
<b>GBA 110005</b>	<b>744.42</b>	1.0	<b>115</b>	946000	1.2	<b>131</b>	896000	1.9	<b>182</b>	776000	3.9	<b>296</b>	630000	2250000	131 (H-F)
	<b>888.23</b>	0.84	<b>115</b>	1129000	1.0	<b>131</b>	1069000	1.6	<b>182</b>	926000	3.3	<b>296</b>	752000	2250000	
	<b>1044.97</b>	0.72	<b>115</b>	1328000	0.86	<b>131</b>	1257000	1.4	<b>182</b>	1090000	2.8	<b>296</b>	885000	2250000	
	<b>1123.93</b>	0.67	<b>115</b>	1428000	0.80	<b>131</b>	1352000	1.3	<b>182</b>	1172000	2.6	<b>296</b>	952000	2250000	
	<b>1333.89</b>	0.56	<b>80</b>	1182000	0.67	<b>95</b>	1170000	1.1	<b>149</b>	1139000	2.2	<b>296</b>	960000	2250000	
	<b>1462.86</b>	0.51	<b>89</b>	1442000	0.62	<b>104</b>	1402000	0.99	<b>156</b>	1305000	2.0	<b>288</b>	1205000	2250000	
	<b>1591.57</b>	0.47	<b>80</b>	1411000	0.57	<b>95</b>	1396000	0.91	<b>149</b>	1359000	1.8	<b>271</b>	1230000	2250000	
	<b>1736.14</b>	0.43	<b>77</b>	1479000	0.52	<b>90</b>	1439000	0.84	<b>135</b>	1339000	1.7	<b>245</b>	1217000	2250000	
	<b>2042.52</b>	0.37	<b>67</b>	1516000	0.44	<b>78</b>	1475000	0.71	<b>118</b>	1372000	1.4	<b>212</b>	1236000	2250000	
	<b>2222.64</b>	0.34	<b>54</b>	1445000	0.40	<b>69</b>	1412000	0.65	<b>108</b>	1374000	1.3	<b>197</b>	1252000	2250000	
	<b>2418.20</b>	0.31	<b>54</b>	1576000	0.37	<b>64</b>	1430000	0.60	<b>101</b>	1391000	1.2	<b>190</b>	1311000	2250000	
	<b>2637.86</b>	0.28	<b>47</b>	1615000	0.34	<b>63</b>	1533000	0.55	<b>95</b>	1427000	1.1	<b>170</b>	1285000	2250000	
	<b>3103.36</b>	0.24	<b>36.5</b>	1250000	0.29	<b>55</b>	1571000	0.47	<b>82</b>	1462000	0.93	<b>148</b>	1316000	2250000	
	<b>3683.11</b>	0.20	<b>31.5</b>	1283000	0.24	<b>36.8</b>	1248000	0.39	<b>55</b>	1161000	0.79	<b>99</b>	1045000	2250000	
	<b>GBA 110006</b>	<b>2523.90</b>	0.30	<b>60</b>	1619000	0.36	<b>70</b>	1575000	0.57	<b>104</b>	1465000	1.1	<b>182</b>	1282000	
<b>2969.29</b>		0.25	<b>52</b>	1659000	0.30	<b>61</b>	1614000	0.49	<b>91</b>	1502000	1.0	<b>163</b>	1352000	2250000	
<b>3239.00</b>		0.23	<b>47.3</b>	1649000	0.28	<b>55</b>	1604000	0.45	<b>83</b>	1495000	0.90	<b>152</b>	1370000	2250000	
<b>3542.91</b>		0.21	<b>44.7</b>	1704000	0.25	<b>52</b>	1658000	0.41	<b>78</b>	1542000	0.82	<b>141</b>	1389000	2250000	
<b>3864.72</b>		0.19	<b>41.5</b>	1727000	0.23	<b>48.4</b>	1680000	0.38	<b>73</b>	1563000	0.75	<b>131</b>	1407000	2250000	
<b>4506.23</b>		0.17	<b>36.4</b>	1767000	0.20	<b>42.5</b>	1719000	0.32	<b>62</b>	1547000	0.64	<b>115</b>	1440000	2250000	
<b>5071.95</b>		0.15	<b>32.9</b>	1799000	0.18	<b>38.4</b>	1750000	0.29	<b>58</b>	1628000	0.57	<b>104</b>	1466000	2250000	
<b>5652.95</b>		0.13	<b>30.0</b>	1800000	0.16	<b>35.1</b>	1779000	0.26	<b>53</b>	1655000	0.51	<b>95</b>	1490000	2250000	
<b>6317.56</b>		0.12	<b>27.3</b>	1800000	0.14	<b>31.9</b>	1800000	0.23	<b>47.8</b>	1683000	0.46	<b>86</b>	1516000	2250000	
<b>7100.24</b>		0.11	<b>23.9</b>	1800000	0.13	<b>27.9</b>	1781000	0.20	<b>41.9</b>	1657000	0.41	<b>75</b>	1492000	2250000	
<b>7925.21</b>		0.09	<b>22.5</b>	1800000	0.11	<b>26.3</b>	1800000	0.18	<b>39.5</b>	1742000	0.37	<b>71</b>	1569000	2250000	
<b>8907.05</b>		0.08	<b>20.4</b>	1800000	0.10	<b>23.8</b>	1800000	0.16	<b>34.6</b>	1715000	0.33	<b>64</b>	1597000	2250000	
<b>9913.71</b>		0.08	<b>18.0</b>	1800000	0.09	<b>21.1</b>	1800000	0.15	<b>31.6</b>	1743000	0.29	<b>57</b>	1569000	2250000	
<b>11231.22</b>		0.07	<b>16.2</b>	1800000	0.08	<b>18.9</b>	1800000	0.13	<b>28.4</b>	1776000	0.26	<b>51</b>	1599000	2250000	
<b>12081.15</b>		0.06	<b>14.1</b>	1800000	0.07	<b>16.5</b>	1787000	0.12	<b>24.7</b>	1663000	0.24	<b>44.5</b>	1497000	2250000	
<b>14213.12</b>		0.05	<b>12.3</b>	1800000	0.06	<b>14.4</b>	1800000	0.10	<b>21.5</b>	1704000	0.20	<b>38.8</b>	1535000	2250000	
<b>15819.46</b>		0.05	<b>9.4</b>	1599000	0.06	<b>11.0</b>	1556000	0.09	<b>16.4</b>	1447000	0.18	<b>29.6</b>	1303000	2250000	
<b>18240.17</b>		0.04	<b>10.7</b>	1800000	0.05	<b>12.5</b>	1800000	0.08	<b>18.8</b>	1800000	0.16	<b>33.9</b>	1721000	2250000	
<b>21647.68</b>	0.03	<b>7.2</b>	1677000	0.04	<b>8.4</b>	1631000	0.07	<b>12.6</b>	1518000	0.13	<b>22.7</b>	1367000	2250000		

	ie	n <sub>1</sub> = 750 RPM			n <sub>1</sub> = 900 RPM			n <sub>1</sub> = 1450 RPM			n <sub>1</sub> = 2900 RPM			T <sub>2max</sub> [Nm]	P <sub>t</sub> [kW]
		n <sub>2</sub> [RPM]	P <sub>1</sub> [kW]	T <sub>2</sub> [Nm]	n <sub>2</sub> [RPM]	P <sub>1</sub> [kW]	T <sub>2</sub> [Nm]	n <sub>2</sub> [RPM]	P <sub>1</sub> [kW]	T <sub>2</sub> [Nm]	n <sub>2</sub> [RPM]	P <sub>1</sub> [kW]	T <sub>2</sub> [Nm]		
<b>GB 130001</b>	<b>4.32</b>	174	<b>13431</b>	720000	—	—	—	—	—	—	—	—	—	2720000	585 (H-F)
<b>GB 130002</b>	<b>16.56</b>	45.3	<b>4914</b>	985000	54	<b>5583</b>	933000	—	—	—	—	—	—	2720000	340 (H-F)
<b>GB 130003</b>	<b>63.48</b>	11.8	<b>1551</b>	1162000	14.2	<b>1842</b>	1150000	22.8	<b>2888</b>	1119000	—	—	—	2720000	243 (H-F)
	<b>72.86</b>	10.3	<b>1362</b>	1171000	12.4	<b>1618</b>	1159000	19.9	<b>2536</b>	1128000	—	—	—	2720000	
<b>GB 130004</b>	<b>243.76</b>	3.1	<b>479</b>	1342000	3.7	<b>559</b>	1306000	5.9	<b>837</b>	1215000	—	—	—	2720000	190 (H-F)
	<b>279.80</b>	2.7	<b>426</b>	1370000	3.2	<b>497</b>	1333000	5.2	<b>745</b>	1240000	—	—	—	2720000	
	<b>328.60</b>	2.3	<b>371</b>	1404000	2.7	<b>434</b>	1366000	4.4	<b>650</b>	1271000	—	—	—	2720000	
	<b>377.18</b>	2.0	<b>330</b>	1434000	2.4	<b>386</b>	1395000	3.8	<b>578</b>	1298000	—	—	—	2720000	
<b>GB 130005</b>	<b>835.76</b>	0.90	<b>172</b>	1617000	1.1	<b>201</b>	1573000	1.7	<b>302</b>	1464000	3.5	<b>544</b>	1318000	2720000	156 (H-F)
	<b>997.21</b>	0.75	<b>148</b>	1661000	0.90	<b>173</b>	1616000	1.5	<b>260</b>	1503000	2.9	<b>468</b>	1354000	2720000	
	<b>1126.64</b>	0.67	<b>134</b>	1692000	0.80	<b>156</b>	1646000	1.3	<b>234</b>	1531000	2.6	<b>422</b>	1379000	2720000	
	<b>1293.18</b>	0.58	<b>119</b>	1728000	0.70	<b>139</b>	1681000	1.1	<b>208</b>	1564000	2.2	<b>375</b>	1408000	2720000	
	<b>1468.94</b>	0.51	<b>107</b>	1761000	0.61	<b>125</b>	1713000	0.99	<b>187</b>	1594000	2.0	<b>337</b>	1435000	2720000	
	<b>1543.00</b>	0.49	<b>102</b>	1774000	0.58	<b>120</b>	1726000	0.94	<b>179</b>	1606000	1.9	<b>323</b>	1446000	2720000	
	<b>1725.16</b>	0.43	<b>93</b>	1805000	0.52	<b>109</b>	1756000	0.84	<b>163</b>	1633000	1.7	<b>294</b>	1471000	2720000	
	<b>1980.19</b>	0.38	<b>83</b>	1843000	0.45	<b>97</b>	1793000	0.73	<b>145</b>	1668000	1.5	<b>261</b>	1502000	2720000	
<b>2350.11</b>	0.32	<b>72</b>	1891000	0.38	<b>84</b>	1840000	0.62	<b>125</b>	1712000	1.2	<b>226</b>	1541000	2720000		

	ie	n <sub>1</sub> = 750 RPM			n <sub>1</sub> = 900 RPM			n <sub>1</sub> = 1450 RPM			n <sub>1</sub> = 2900 RPM			T <sub>2max</sub> [Nm]	P <sub>t</sub> [kW]
		n <sub>2</sub> [RPM]	P <sub>1</sub> [kW]	T <sub>2</sub> [Nm]	n <sub>2</sub> [RPM]	P <sub>1</sub> [kW]	T <sub>2</sub> [Nm]	n <sub>2</sub> [RPM]	P <sub>1</sub> [kW]	T <sub>2</sub> [Nm]	n <sub>2</sub> [RPM]	P <sub>1</sub> [kW]	T <sub>2</sub> [Nm]		
<b>GBA 130005</b>	<b>909.34</b>	0.82	<b>163</b>	1638000	0.99	<b>190</b>	1593000	1.6	<b>285</b>	1483000	3.2	<b>514</b>	1335000	2720000	135 (H-F)
	<b>1067.96</b>	0.70	<b>142</b>	1678000	0.84	<b>166</b>	1633000	1.4	<b>249</b>	1519000	2.7	<b>448</b>	1368000	2720000	
	<b>1225.83</b>	0.61	<b>127</b>	1714000	0.73	<b>148</b>	1667000	1.2	<b>221</b>	1551000	2.4	<b>399</b>	1397000	2720000	
<b>GBA 130006</b>	<b>2566.98</b>	0.29	<b>69</b>	1916000	0.35	<b>81</b>	1864000	0.56	<b>121</b>	1735000	1.1	<b>218</b>	1562000	2720000	118 (H-F)
	<b>3062.87</b>	0.24	<b>60</b>	1968000	0.29	<b>70</b>	1915000	0.47	<b>104</b>	1782000	0.95	<b>188</b>	1604000	2720000	
	<b>3515.64</b>	0.21	<b>53</b>	2010000	0.26	<b>62</b>	1955000	0.41	<b>93</b>	1819000	0.82	<b>167</b>	1638000	2720000	
	<b>3971.92</b>	0.19	<b>47.9</b>	2047000	0.23	<b>56</b>	1992000	0.37	<b>84</b>	1853000	0.73	<b>151</b>	1668000	2720000	
	<b>4476.76</b>	0.17	<b>43.2</b>	2085000	0.20	<b>50</b>	2028000	0.32	<b>76</b>	1887000	0.65	<b>136</b>	1699000	2720000	
	<b>5257.64</b>	0.14	<b>37.7</b>	2136000	0.17	<b>44.0</b>	2078000	0.28	<b>66</b>	1933000	0.55	<b>119</b>	1741000	2720000	
	<b>5972.20</b>	0.13	<b>33.9</b>	2176000	0.15	<b>39.5</b>	2118000	0.24	<b>59</b>	1971000	0.49	<b>107</b>	1775000	2720000	
	<b>6288.58</b>	0.12	<b>32.4</b>	2176000	0.14	<b>37.8</b>	2135000	0.23	<b>57</b>	1986000	0.46	<b>102</b>	1789000	2720000	
	<b>7087.88</b>	0.11	<b>29.3</b>	2176000	0.13	<b>34.2</b>	2174000	0.20	<b>51</b>	2023000	0.41	<b>92</b>	1821000	2720000	
	<b>8050.76</b>	0.09	<b>26.3</b>	2176000	0.11	<b>30.7</b>	2176000	0.18	<b>46.0</b>	2062000	0.36	<b>83</b>	1857000	2720000	
	<b>9554.75</b>	0.08	<b>22.7</b>	2176000	0.09	<b>26.5</b>	2176000	0.15	<b>39.8</b>	2116000	0.30	<b>72</b>	1905000	2720000	
	<b>10967.19</b>	0.07	<b>20.2</b>	2176000	0.08	<b>23.6</b>	2176000	0.13	<b>35.4</b>	2161000	0.26	<b>64</b>	1946000	2720000	

	ie	n <sub>1</sub> = 750 RPM			n <sub>1</sub> = 900 RPM			n <sub>1</sub> = 1450 RPM			n <sub>1</sub> = 2900 RPM			T <sub>2max</sub> [Nm]	P <sub>t</sub> [kW]
		n <sub>2</sub> [RPM]	P <sub>1</sub> [kW]	T <sub>2</sub> [Nm]	n <sub>2</sub> [RPM]	P <sub>1</sub> [kW]	T <sub>2</sub> [Nm]	n <sub>2</sub> [RPM]	P <sub>1</sub> [kW]	T <sub>2</sub> [Nm]	n <sub>2</sub> [RPM]	P <sub>1</sub> [kW]	T <sub>2</sub> [Nm]		
<b>GB 150001</b>	<b>4.07</b>	—	—	—	—	—	—	—	—	—	—	—	—	2720000	585 (H-F)
<b>GB 150002</b>	<b>15.62</b>	48.0	<b>4914</b>	929000	58	<b>5583</b>	880000	—	—	—	—	—	—	2720000	340 (H-F)
<b>GB 150003</b>	<b>59.87</b>	12.5	<b>1968</b>	1390000	15.0	<b>2236</b>	1316000	24.2	<b>3122</b>	1141000	—	—	—	2720000	246 (H-F)
	<b>68.72</b>	10.9	<b>1742</b>	1413000	13.1	<b>2030</b>	1372000	21.1	<b>2834</b>	1189000	—	—	—	2720000	
<b>GB 150004</b>	<b>248.02</b>	3.0	<b>563</b>	1607000	3.6	<b>657</b>	1563000	5.8	<b>986</b>	1456000	—	—	—	2720000	192 (H-F)
	<b>284.68</b>	2.6	<b>501</b>	1640000	3.2	<b>585</b>	1596000	5.1	<b>876</b>	1485000	—	—	—	2720000	
	<b>323.28</b>	2.3	<b>450</b>	1672000	2.8	<b>525</b>	1627000	4.5	<b>787</b>	1513000	—	—	—	2720000	
	<b>371.07</b>	2.0	<b>400</b>	1707000	2.4	<b>467</b>	1661000	3.9	<b>700</b>	1545000	—	—	—	2720000	
	<b>389.13</b>	1.9	<b>384</b>	1720000	2.3	<b>448</b>	1673000	3.7	<b>672</b>	1557000	—	—	—	2720000	
	<b>446.65</b>	1.7	<b>342</b>	1756000	2.0	<b>399</b>	1708000	3.2	<b>598</b>	1589000	—	—	—	2720000	
<b>GB 150005</b>	<b>950.73</b>	0.79	<b>185</b>	1969000	0.95	<b>215</b>	1915000	1.5	<b>323</b>	1782000	3.05	<b>582</b>	1604000	2720000	158 (H-F)
	<b>1091.28</b>	0.69	<b>164</b>	2010000	0.82	<b>192</b>	1955000	1.3	<b>287</b>	1819000	2.66	<b>517</b>	1638000	2720000	
	<b>1239.23</b>	0.61	<b>147</b>	2049000	0.73	<b>172</b>	1993000	1.2	<b>258</b>	1855000	2.34	<b>464</b>	1670000	2720000	
	<b>1302.09</b>	0.58	<b>141</b>	2065000	0.69	<b>165</b>	2008000	1.1	<b>247</b>	1869000	2.23	<b>445</b>	1683000	2720000	
	<b>1422.42</b>	0.53	<b>131</b>	2092000	0.63	<b>153</b>	2035000	1.0	<b>229</b>	1894000	2.04	<b>413</b>	1705000	2720000	
	<b>1491.67</b>	0.50	<b>119</b>	1999000	0.60	<b>142</b>	1978000	0.97	<b>220</b>	1907000	1.94	<b>397</b>	1718000	2720000	
	<b>1494.57</b>	0.50	<b>126</b>	2108000	0.60	<b>147</b>	2051000	0.97	<b>220</b>	1908000	1.94	<b>396</b>	1718000	2720000	
	<b>1697.21</b>	0.44	<b>113</b>	2149000	0.53	<b>132</b>	2091000	0.85	<b>197</b>	1945000	1.71	<b>356</b>	1751000	2720000	
	<b>1712.17</b>	0.44	<b>112</b>	2152000	0.53	<b>131</b>	2093000	0.85	<b>196</b>	1948000	1.69	<b>353</b>	1754000	2720000	
	<b>1948.10</b>	0.38	<b>100</b>	2176000	0.46	<b>117</b>	2135000	0.74	<b>176</b>	1986000	1.49	<b>316</b>	1788000	2720000	
	<b>2042.94</b>	0.37	<b>89</b>	2035000	0.44	<b>105</b>	2014000	0.71	<b>165</b>	1960000	1.42	<b>304</b>	1801000	2720000	
	<b>2344.94</b>	0.32	<b>86</b>	2176000	0.38	<b>100</b>	2176000	0.62	<b>150</b>	2043000	1.24	<b>270</b>	1839000	2720000	

	ie	n <sub>1</sub> = 750 RPM			n <sub>1</sub> = 900 RPM			n <sub>1</sub> = 1450 RPM			n <sub>1</sub> = 2900 RPM			T <sub>2max</sub> [Nm]	P <sub>t</sub> [kW]
		n <sub>2</sub> [RPM]	P <sub>1</sub> [kW]	T <sub>2</sub> [Nm]	n <sub>2</sub> [RPM]	P <sub>1</sub> [kW]	T <sub>2</sub> [Nm]	n <sub>2</sub> [RPM]	P <sub>1</sub> [kW]	T <sub>2</sub> [Nm]	n <sub>2</sub> [RPM]	P <sub>1</sub> [kW]	T <sub>2</sub> [Nm]		
<b>GB 205001</b>	4.14	—	—	—	—	—	—	—	—	—	—	—	—	3620000	870 (H-F)
<b>GB 205002</b>	15.89	47.2	<b>6744</b>	1297000	—	—	—	—	—	—	—	—	—	3620000	498 (H-F)
	22.50	33.3	<b>4422</b>	1204000	—	—	—	—	—	—	—	—	—	3620000	
<b>GB 205003</b>	58.47	12.8	<b>2530</b>	1746000	15.4	<b>2875</b>	1653000	—	—	—	—	—	—	3620000	357 (H-F)
	78.51	9.6	<b>1988</b>	1842000	11.5	<b>2259</b>	1744000	—	—	—	—	—	—	3620000	
	82.80	9.1	<b>1328</b>	1297000	10.9	<b>1577</b>	1284000	—	—	—	—	—	—	3620000	
	111.18	6.7	<b>1006</b>	1319000	8.1	<b>1194</b>	1306000	—	—	—	—	—	—	3620000	
<b>GB 205004</b>	239.21	3.1	<b>834</b>	2296000	3.8	<b>974</b>	2234000	6.1	<b>1460</b>	2078000	—	—	—	3620000	280 (H-F)
	306.99	2.4	<b>669</b>	2362000	2.9	<b>788</b>	2320000	4.7	<b>1181</b>	2158000	—	—	—	3620000	
	321.19	2.3	<b>642</b>	2371000	2.8	<b>758</b>	2336000	4.5	<b>1137</b>	2173000	—	—	—	3620000	
	338.73	2.2	<b>361</b>	1406000	2.7	<b>428</b>	1392000	4.3	<b>672</b>	1354000	—	—	—	3620000	
	364.34	2.1	<b>576</b>	2417000	2.5	<b>676</b>	2361000	4.0	<b>1021</b>	2215000	—	—	—	3310000	
	412.20	1.8	<b>519</b>	2462000	2.2	<b>606</b>	2395000	3.5	<b>920</b>	2257000	—	—	—	3620000	
	434.70	1.7	<b>285</b>	1426000	2.1	<b>339</b>	1411000	3.3	<b>531</b>	1374000	—	—	—	3620000	
	454.81	1.6	<b>273</b>	1430000	2.0	<b>324</b>	1415000	3.2	<b>509</b>	1377000	—	—	—	3620000	
	489.20	1.5	<b>449</b>	2527000	1.8	<b>524</b>	2458000	3.0	<b>795</b>	2316000	—	—	—	3310000	
	515.91	1.5	<b>244</b>	1446000	1.7	<b>288</b>	1425000	2.8	<b>452</b>	1387000	—	—	—	3620000	
	583.68	1.3	<b>219</b>	1473000	1.5	<b>256</b>	1435000	2.5	<b>402</b>	1397000	—	—	—	3620000	
	692.71	1.1	<b>190</b>	1512000	1.3	<b>221</b>	1470000	2.1	<b>342</b>	1411000	—	—	—	3620000	
<b>GB 205005</b>	956.85	0.78	<b>261</b>	2797000	0.94	<b>304</b>	2721000	1.5	<b>456</b>	2532000	3.0	<b>831</b>	2308000	3620000	230 (H-F)
	1125.70	0.67	<b>227</b>	2867000	0.80	<b>265</b>	2789000	1.3	<b>397</b>	2595000	2.6	<b>721</b>	2355000	3620000	
	1227.95	0.61	<b>211</b>	2896000	0.73	<b>246</b>	2826000	1.2	<b>369</b>	2629000	2.4	<b>664</b>	2367000	3620000	
	1284.77	0.58	<b>192</b>	2762000	0.70	<b>228</b>	2733000	1.1	<b>355</b>	2647000	2.3	<b>639</b>	2383000	3620000	
	1354.91	0.55	<b>110</b>	2896000	0.66	<b>128</b>	2896000	1.1	<b>193</b>	1514000	2.1	<b>358</b>	1409000	3620000	
	1444.65	0.52	<b>184</b>	2896000	0.62	<b>214</b>	2900000	1.0	<b>321</b>	2694000	2.0	<b>579</b>	2426000	3620000	
	1457.35	0.51	<b>182</b>	2788000	0.62	<b>213</b>	2759000	0.99	<b>319</b>	2698000	2.0	<b>575</b>	2429000	3620000	
	1511.49	0.50	<b>164</b>	1715000	0.60	<b>195</b>	1668000	0.96	<b>306</b>	2685000	1.9	<b>557</b>	2443000	3310000	
	1594.01	0.47	<b>96</b>	2802000	0.56	<b>112</b>	2773000	0.91	<b>168</b>	1552000	1.8	<b>307</b>	1422000	3620000	
	1648.79	0.45	<b>151</b>	2896000	0.55	<b>180</b>	2896000	0.88	<b>282</b>	2698000	1.8	<b>517</b>	2475000	3620000	
	1714.53	0.44	<b>159</b>	1737000	0.52	<b>185</b>	1690000	0.85	<b>278</b>	2765000	1.7	<b>500</b>	2490000	3310000	
	1738.80	0.43	<b>89</b>	1749000	0.52	<b>104</b>	1702000	0.83	<b>156</b>	1573000	1.7	<b>283</b>	1429000	3310000	
	1819.25	0.41	<b>86</b>	2828000	0.49	<b>100</b>	2798000	0.80	<b>150</b>	1583000	1.6	<b>271</b>	1433000	3620000	
	1939.75	0.39	<b>130</b>	2829000	0.46	<b>154</b>	2800000	0.75	<b>242</b>	2723000	1.5	<b>451</b>	2537000	3620000	
	1956.80	0.38	<b>129</b>	1783000	0.46	<b>153</b>	1735000	0.74	<b>240</b>	2725000	1.5	<b>447</b>	2540000	3310000	
	2045.65	0.37	<b>78</b>	1793000	0.44	<b>91</b>	1744000	0.71	<b>136</b>	1612000	1.4	<b>244</b>	1451000	3310000	
	2063.63	0.36	<b>77</b>	2861000	0.44	<b>90</b>	2826000	0.70	<b>135</b>	1614000	1.4	<b>243</b>	1453000	3620000	
	2140.30	0.35	<b>75</b>	1827000	0.42	<b>87</b>	1778000	0.68	<b>131</b>	1623000	1.4	<b>235</b>	1461000	3310000	
	2302.12	0.33	<b>111</b>	1862000	0.39	<b>131</b>	1811000	0.63	<b>206</b>	2750000	1.3	<b>390</b>	2603000	3310000	
	2334.71	0.32	<b>69</b>	1864000	0.39	<b>81</b>	1814000	0.62	<b>121</b>	1644000	1.2	<b>219</b>	1481000	3310000	
	2427.80	0.31	<b>67</b>	1911000	0.37	<b>78</b>	1859000	0.60	<b>117</b>	1654000	1.2	<b>211</b>	1489000	3310000	
	2746.71	0.27	<b>60</b>	1862000	0.33	<b>71</b>	1811000	0.53	<b>106</b>	1685000	1.1	<b>190</b>	1517000	3293000	
2770.86	0.27	<b>60</b>	1864000	0.32	<b>70</b>	1814000	0.52	<b>105</b>	1687000	1.0	<b>189</b>	1519000	3293000		
3259.83	0.23	<b>52</b>	1911000	0.28	<b>61</b>	1859000	0.44	<b>91</b>	1729000	0.89	<b>165</b>	1557000	3293000		

	ie	n <sub>1</sub> = 750 RPM			n <sub>1</sub> = 900 RPM			n <sub>1</sub> = 1450 RPM			n <sub>1</sub> = 2900 RPM			T <sub>2max</sub> [Nm]	P <sub>t</sub> [kW]
		n <sub>2</sub> [RPM]	P <sub>1</sub> [kW]	T <sub>2</sub> [Nm]	n <sub>2</sub> [RPM]	P <sub>1</sub> [kW]	T <sub>2</sub> [Nm]	n <sub>2</sub> [RPM]	P <sub>1</sub> [kW]	T <sub>2</sub> [Nm]	n <sub>2</sub> [RPM]	P <sub>1</sub> [kW]	T <sub>2</sub> [Nm]		
<b>GB 235001</b>	4.14	—	—	—	—	—	—	—	—	—	—	—	—	3620000	870 (H-F)
<b>GB 235002</b>	15.89	47.2	<b>8992</b>	1730000	—	—	—	—	—	—	—	—	—	3620000	508 (H-F)
<b>GB 235003</b>	<b>54.48</b>	13.8	<b>3467</b>	2229000	16.5	<b>4118</b>	2206000	—	—	—	—	—	—	3620000	371 (H-F)
	<b>65.00</b>	11.5	<b>2936</b>	2252000	13.8	<b>3486</b>	2229000	—	—	—	—	—	—	3620000	
	<b>83.42</b>	9.0	<b>2320</b>	2284000	10.8	<b>2755</b>	2261000	—	—	—	—	—	—	3620000	
	<b>99.00</b>	7.6	<b>1974</b>	2307000	9.1	<b>2345</b>	2283000	—	—	—	—	—	—	3620000	
<b>GB 235004</b>	<b>222.87</b>	3.4	<b>984</b>	2522000	4.0	<b>1148</b>	2454000	6.5	<b>1754</b>	2327000	—	—	—	3620000	291 (H-F)
	<b>265.92</b>	2.8	<b>847</b>	2591000	3.4	<b>988</b>	2520000	5.5	<b>1485</b>	2351000	—	—	—	3620000	
	<b>286.01</b>	2.6	<b>796</b>	2619000	3.1	<b>929</b>	2548000	5.1	<b>1393</b>	2371000	—	—	—	3620000	
	<b>339.44</b>	2.2	<b>688</b>	2688000	2.7	<b>803</b>	2615000	4.3	<b>1204</b>	2433000	—	—	—	3620000	
	<b>341.27</b>	2.2	<b>685</b>	2690000	2.6	<b>800</b>	2617000	4.2	<b>1199</b>	2435000	—	—	—	3620000	
	<b>341.27</b>	2.2	<b>685</b>	2690000	2.2	<b>692</b>	2686000	4.2	<b>1199</b>	2435000	—	—	—	3620000	
	<b>405.02</b>	1.9	<b>592</b>	2761000	2.1	<b>647</b>	2718000	3.6	<b>1037</b>	2499000	—	—	—	3620000	
	<b>437.96</b>	1.7	<b>554</b>	2794000	1.7	<b>560</b>	2789000	3.3	<b>970</b>	2529000	—	—	—	3620000	
	<b>519.78</b>	1.4	<b>479</b>	2867000	1.7	<b>560</b>	2789000	2.8	<b>839</b>	2595000	—	—	—	3620000	
	<b>616.88</b>	1.2	<b>415</b>	2896000	1.5	<b>484</b>	2862000	2.4	<b>725</b>	2663000	—	—	—	3620000	
<b>GB 235005</b>	<b>891.47</b>	0.84	<b>311</b>	2896000	1.0	<b>363</b>	2896000	1.6	<b>544</b>	2816000	3.3	<b>980</b>	2535000	3620000	238 (H-F)
	<b>1048.79</b>	0.72	<b>271</b>	2896000	0.86	<b>316</b>	2896000	1.4	<b>474</b>	2886000	2.8	<b>854</b>	2599000	3620000	
	<b>1063.69</b>	0.71	<b>268</b>	2896000	0.85	<b>313</b>	2896000	1.4	<b>469</b>	2892000	2.7	<b>844</b>	2604000	3620000	
	<b>1144.06</b>	0.66	<b>252</b>	2896000	0.79	<b>294</b>	2896000	1.3	<b>440</b>	2896000	2.5	<b>793</b>	2633000	3620000	
	<b>1251.40</b>	0.60	<b>233</b>	2896000	0.72	<b>272</b>	2896000	1.2	<b>408</b>	2896000	2.3	<b>735</b>	2669000	3620000	
	<b>1345.95</b>	0.56	<b>219</b>	2896000	0.67	<b>256</b>	2896000	1.1	<b>384</b>	2896000	2.2	<b>691</b>	2698000	3620000	
	<b>1357.78</b>	0.55	<b>218</b>	2896000	0.66	<b>254</b>	2896000	1.1	<b>381</b>	2896000	2.1	<b>686</b>	2702000	3620000	
	<b>1365.07</b>	0.55	<b>217</b>	2896000	0.66	<b>253</b>	2896000	1.1	<b>379</b>	2896000	2.1	<b>683</b>	2704000	3620000	
	<b>1597.39</b>	0.47	<b>190</b>	2896000	0.56	<b>221</b>	2896000	0.91	<b>332</b>	2896000	1.8	<b>597</b>	2769000	3620000	
	<b>1605.96</b>	0.47	<b>189</b>	2896000	0.56	<b>220</b>	2896000	0.90	<b>330</b>	2896000	1.8	<b>595</b>	2772000	3620000	
	<b>1620.08</b>	0.46	<b>187</b>	2896000	0.56	<b>219</b>	2896000	0.90	<b>328</b>	2896000	1.8	<b>590</b>	2775000	3620000	
	<b>1751.83</b>	0.43	<b>175</b>	2896000	0.51	<b>205</b>	2896000	0.83	<b>307</b>	2896000	1.7	<b>552</b>	2808000	3620000	
	<b>1905.97</b>	0.39	<b>163</b>	2896000	0.47	<b>191</b>	2896000	0.76	<b>286</b>	2896000	1.5	<b>514</b>	2844000	3620000	
	<b>2060.98</b>	0.36	<b>153</b>	2896000	0.44	<b>178</b>	2896000	0.70	<b>267</b>	2896000	1.4	<b>481</b>	2878000	3620000	
	<b>2079.10</b>	0.36	<b>152</b>	2896000	0.43	<b>177</b>	2896000	0.70	<b>265</b>	2896000	1.4	<b>478</b>	2882000	3620000	
	<b>2446.00</b>	0.31	<b>132</b>	2896000	0.37	<b>154</b>	2896000	0.59	<b>231</b>	2896000	1.2	<b>416</b>	2896000	3620000	
	<b>2467.50</b>	0.30	<b>131</b>	2896000	0.36	<b>153</b>	2896000	0.59	<b>229</b>	2896000	1.2	<b>413</b>	2896000	3620000	
	<b>2902.95</b>	0.26	<b>114</b>	2896000	0.31	<b>133</b>	2896000	0.50	<b>200</b>	2896000	1.0	<b>360</b>	2896000	3620000	

**N** (110-210-310-510-810) - **P** (110-210-310-510-610)

**T** (240-310-510-810-1020-1520-2000) - **TL** (310-510) - **P** (810-1020)

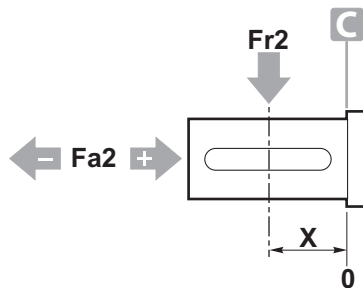
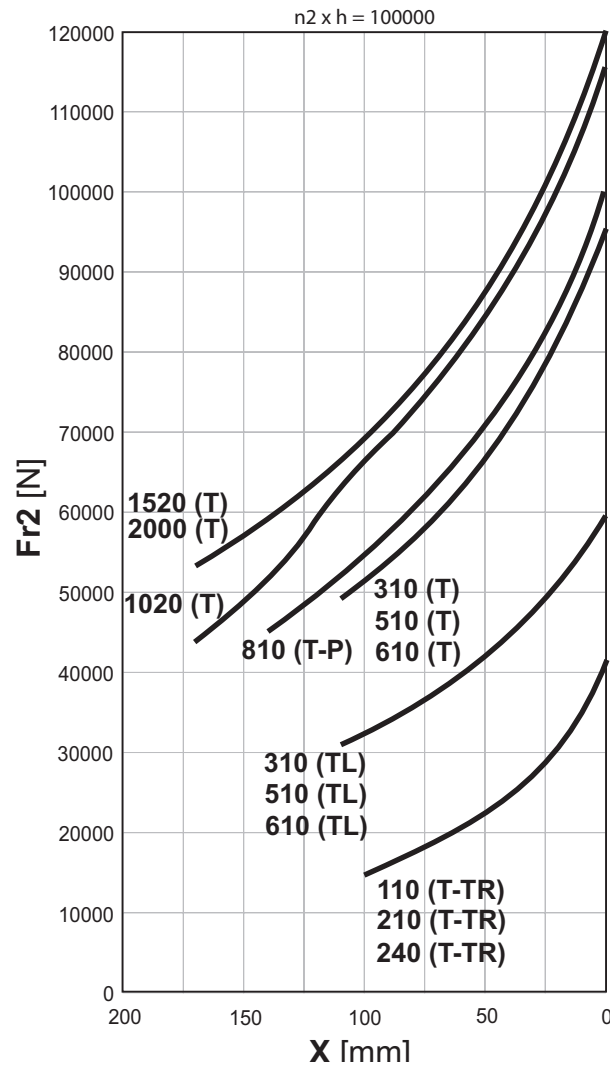
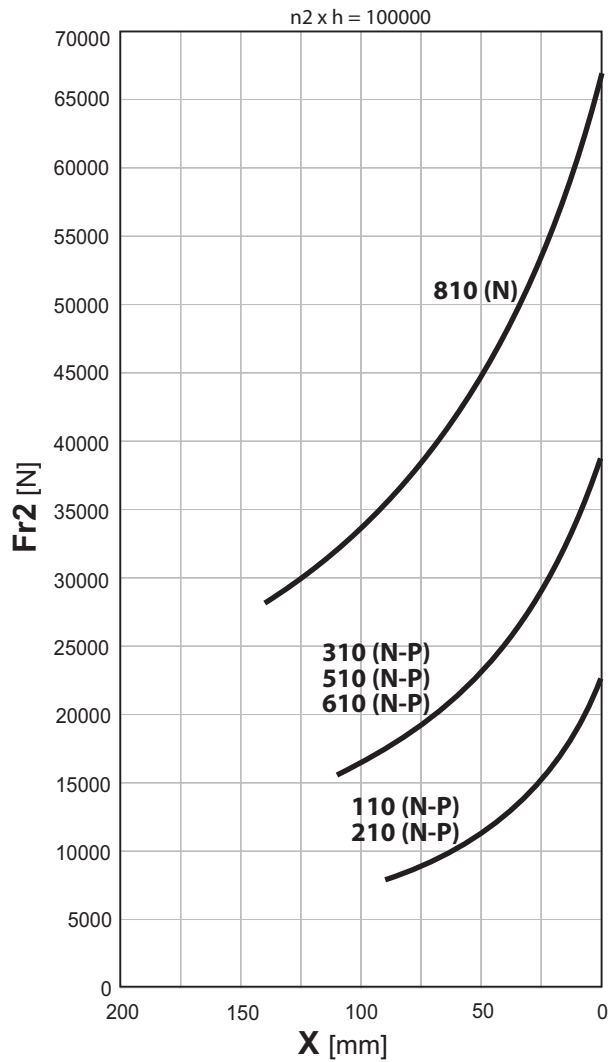

$n_2 \times h = 100000$

RE-RA	Fa2 [N]									
	FS		N		P		T		TL	
	Fa2 (-)	Fa2 (+)	Fa2 (-)	Fa2 (+)	Fa2 (-)	Fa2 (+)	Fa2 (-)	Fa2 (+)	Fa2 (-)	Fa2 (+)
110	6800	6800	19250	19250	19250	19250	22500	35500	—	—
210	6800	6800	19250	19250	19250	19250	22500	35500	—	—
240	7350	7350	—	—	—	—	25700	34400	—	—
310	10500	10500	39500	39500	58400	58400	57500	78500	48500	48500
510	10500	10500	39500	39500	58400	58400	57500	78500	48500	48500
610	10500	10500	39500	39500	58400	58400	57500	78500	48500	48500
810	21500	21500	58400	58400	58400	88500	58400	88500	—	—
1020	19000	19000	—	—	58400	88000	60500	104500	—	—
1520	27000	27000	—	—	—	—	73400	104500	—	—
2000	27000	27000	—	—	—	—	73400	104500	—	—

$K_f$	$n_2 \times h$						
	20000	40000	60000	80000	100000	200000	400000
	1.7	1.3	1.15	1.06	1	0.8	0.63

**H** (1520-2000-2520-3000-3510)

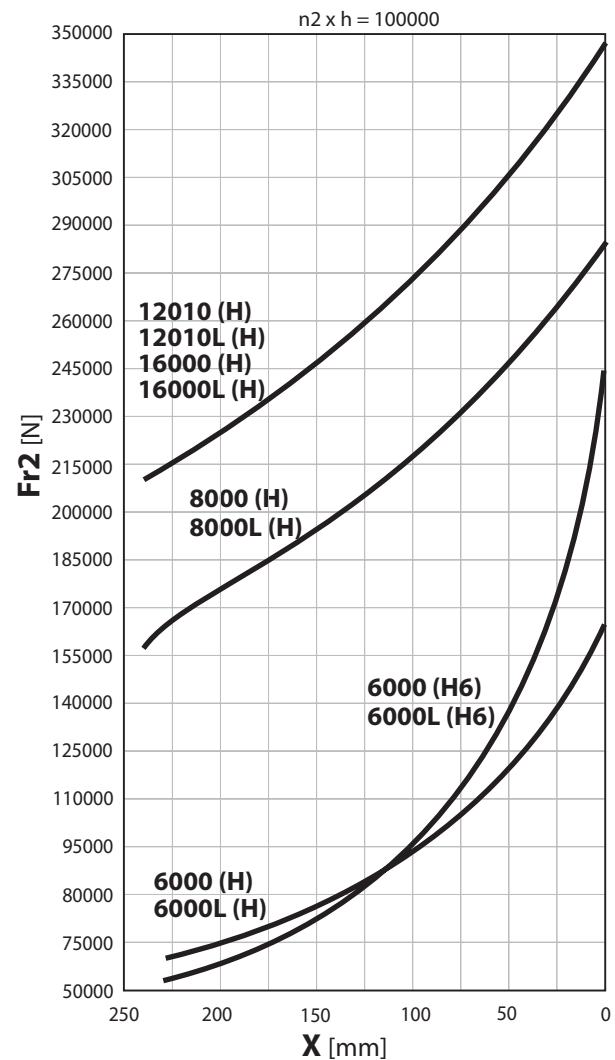
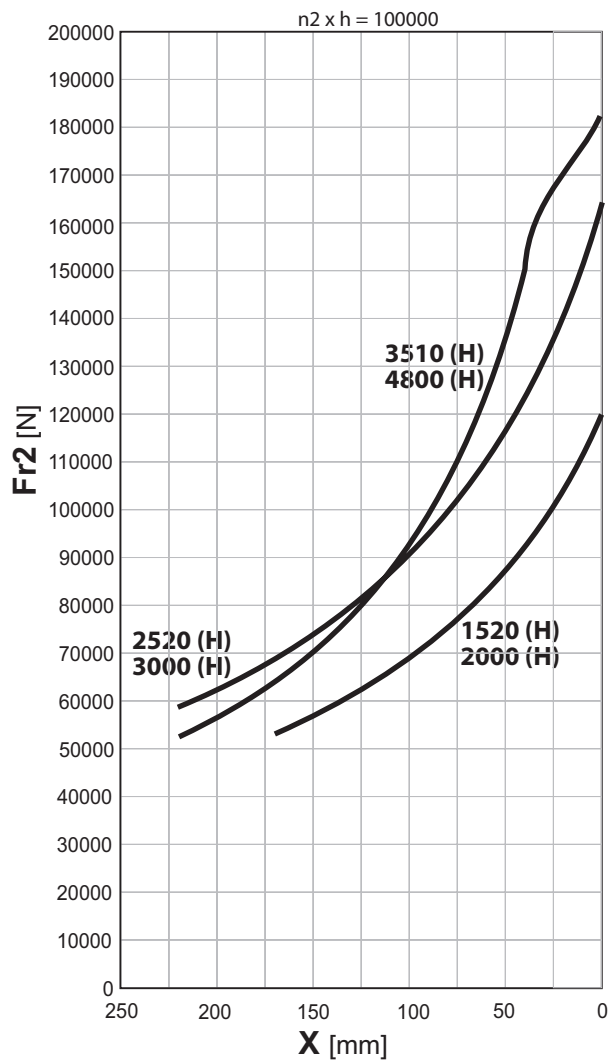
**H** (6000-8000-12010-16000) - **H6** (6000)

 $n_2 \times h = 100000$ 
**Fa2 [N]**

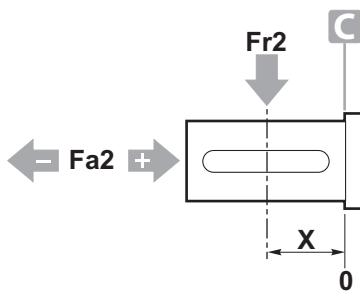
RE-RA	FS		FS1		H		H6	
	Fa2 (-)	Fa2 (+)	Fa2 (-)	Fa2 (+)	Fa2 (-)	Fa2 (+)	Fa2 (-)	Fa2 (+)
1520	27000	27000	—	—	73400	104500	—	—
2000	27000	27000	—	—	73400	104500	—	—
2520	29500	29500	—	—	112600	149000	—	—
3000	29500	29500	—	—	112600	149000	—	—
3500	44000	44000	—	—	59000	44000	—	—
4800	44000	44000	65250*	44000	59000	44000	—	—
6000	52000	42000	—	—	148500	131000	94000	42000
8000	67000	56000*	82200*	56000*	94000	56000*	—	—
12010	75000	65250*	—	—	114000	65250*	—	—
16000	75000	65250*	113600*	65250*	114000	65250*	—	—

 \*  $F_a/F_r < 0.4$ 

$K_f$	$n_2 \times h$						
	20000	40000	60000	80000	100000	200000	400000
	1.7	1.3	1.15	1.06	1	0.8	0.63

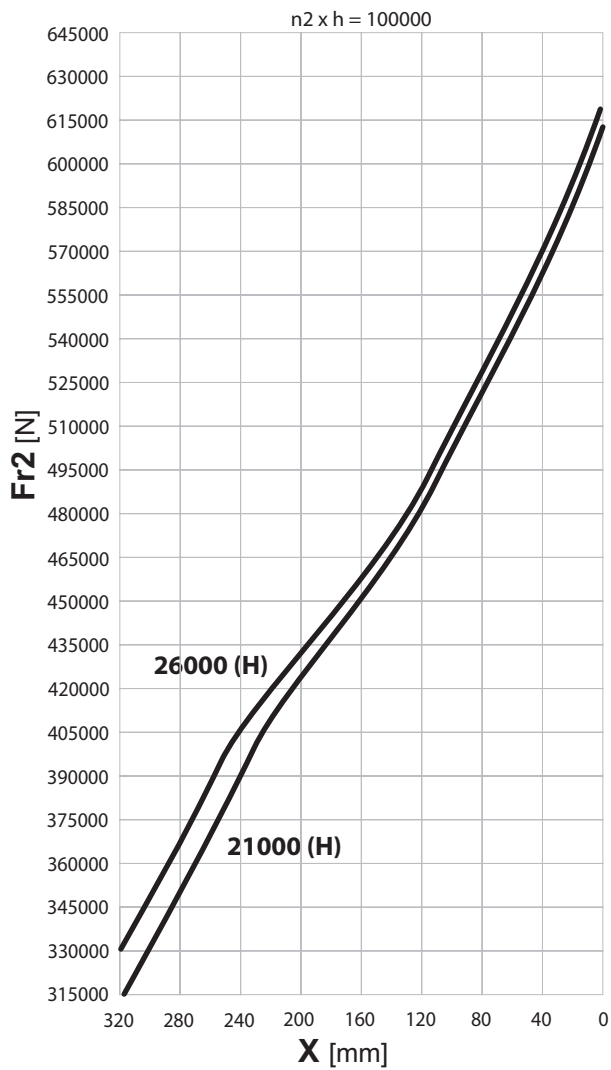
### H (21000-26000)



### H (31000-40000-45000)

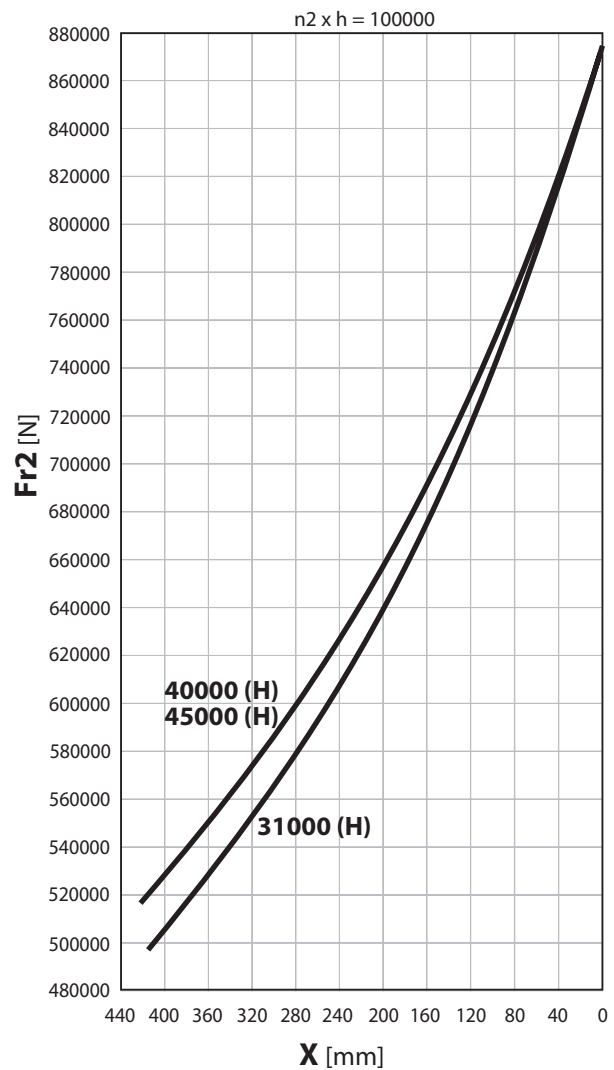

$n_2 \times h = 100000$

GB	Fa2 [N]			
	FS		H	
	Fa2 (-)	Fa2 (+)	Fa2 (-)	Fa2 (+)
21000	113600*	113600*	170000	113600*
26000	160500*	113600*	170000	113600*
31000	240000*	160500*	275000	160500*
40000	240000*	160500*	275000	160500*
45000	260000*	160500*	275000	160500*
53000	185000	185000	—	—
61000	185000	185000	—	—
85000	225000	185000	—	—
110000	315000	230000	—	—
130000	315000	230000	—	—
150000	315000	230000	—	—
205000	550000	315000	—	—
235000	550000	315000	—	—

\* Fa/Fr < 0.4

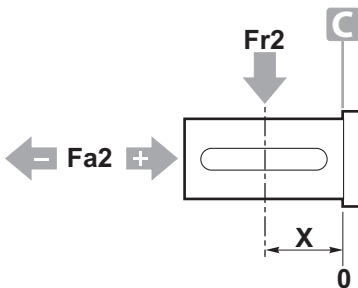

K <sub>f</sub>	n <sub>2</sub> × h						
	20000	40000	60000	80000	100000	200000	400000
	1.7	1.3	1.15	1.06	1	0.8	0.63



I

**DIMENSIONI**

UK

**DIMENSIONS**

**G**



<b>S</b>	<b>N</b>	NS	110 - 210 - 310 - 510 - 610 - 810	G-4
	<b>P</b>	PS	110 - 210 - 310 - 510 - 610 - 810 - 1020	G-6
	<b>T</b>	TS/T1S/TLS/TRS/TR1S	110 - 210 - 240 - 310 - 510 - 610	G-8
		TS	810 - 1020 - 1520 - 2000 - 2000L	G-10
	<b>H</b>	HS	1520 - 2000 - 2000L - 2520 - 3000 - 3510 - 4800	G-12
		HS/H6S	6000 - 8000 - 12010 - 16000	G-14
		HS/H6S	6000L - 8000L - 12010L - 16000L	G-16
		HS	21000 - 26000 - 31000 - 40000 - 45000	G-18



<b>C</b>	<b>N</b>	NC/NK/NK1	110 - 210 - 310 - 510 - 610 - 810	G-20
	<b>P</b>	PC/PK/PK1	110 - 210 - 310 - 510 - 610 - 810 - 1020	G-22
	<b>T</b>	TC/T1C/TLC/TRC/TLK/TR1C	110 - 210 - 240 - 310 - 510 - 610 - 810	G-24
		TC	810 - 1020 - 1520 - 2000 - 2000L	G-26
	<b>H</b>	HC	1520 - 2000 - 2000L - 2520 - 3000 - 3510 - 4800	G-28
		HC/H6C	6000 - 8000 - 12010 - 16000	G-30
		HC/H6C	6000L - 8000L - 12010L - 16000L	G-32
		HC	21000 - 26000 - 31000 - 40000 - 45000	G-34



<b>E</b>	<b>N</b>	NE	110 - 210 - 310 - 510 - 610	G-36
	<b>T</b>	TE/T1E/TRE/TR1E/TLE	110 - 210 - 240 - 310 - 510 - 610	G-38
		TE	810 - 1020 - 1520 - 2000 - 2000L	G-40
	<b>H</b>	HE	1520 - 2000 - 2000L - 2520 - 3000	G-42



<b>S</b>	<b>F</b>	FS	110 - 210 - 240 - 310 - 510 - 810 - 1020	G-44
			1520 - 2000 - 2000L - 2520 - 3000 - 3510 - 4800	G-46
			6000 - 8000 - 12010 - 16000	G-48
			6000L - 8000L - 12010L - 16000L	G-50
			21000 - 26000 - 31000 - 40000 - 45000 53000 - 61000 - 85000	G-52
			110000 - 130000 - 150000 205000 - 235000	G-54
<b>F</b>	<b>N</b>	NF	310 - 510 - 610 - 810	G-56



<b>Q</b>	<b>N</b>	NQ	110 - 210 - 310 - 510 - 610	G-58	
	<b>T</b>	TQ/TRQ	240 - 810 - 1020 - 1520 - 2000 - 2000L	G-60	
	<b>H</b>		HQ	1520 - 2000 - 2000L - 2520 - 3000 - 3510 - 4800	G-62
			HQ/H6Q	6000 - 8000 - 12010 - 16000	G-64
			HQ/H6Q	6000L - 8000L - 12010L - 16000L	G-66
			HQ	21000 - 26000 - 31000 - 40000 - 45000 53000 - 61000 - 85000	G-68
			HQ	110000 - 130000 - 150000 205000 - 235000	G-70



<b>U</b>		TU/NU/NU2	110 - 210 - 310 - 510 - 610	G-72
----------	--	-----------	-----------------------------	------



<b>C</b>		FC	110 - 210	G-74
----------	--	----	-----------	------

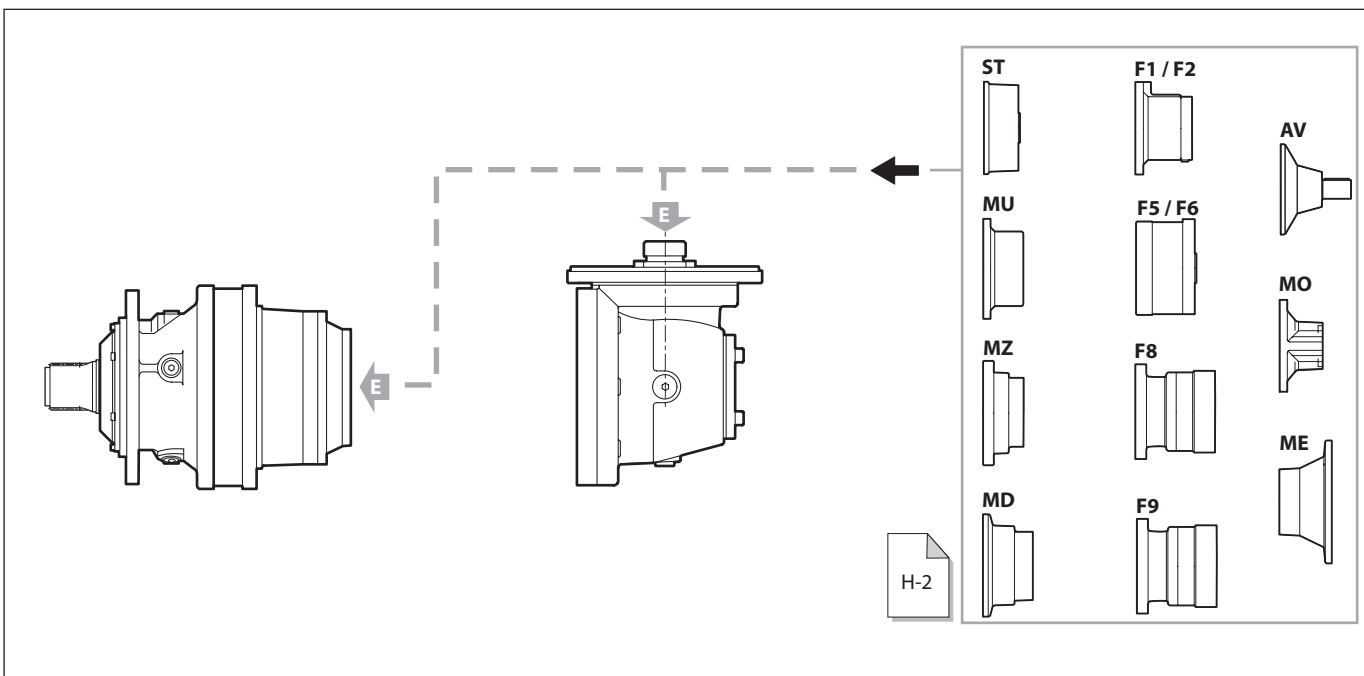

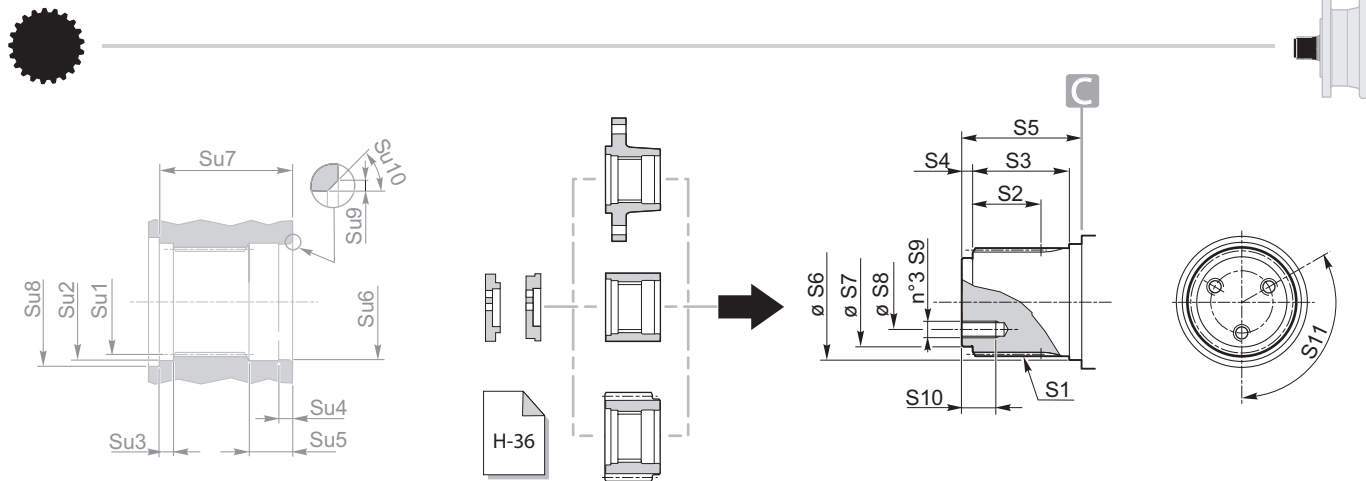

RE - RA						
	110	210	310	510	610	810
<b>S1</b>	B40x36 DIN5482	B40x36 DIN5482	B58x53 DIN5482	B58x53 DIN5482	B58x53 DIN5482	B70x64 DIN5482
<b>S2</b>	30	30	37	37	37	51
<b>S3</b>	43	43	50	50	50	70
<b>S4</b>	5	5	8	8	8	10
<b>S5</b>	55	55	68.5	68.5	68.5	90
<b>S6</b>	42 f7	42 f7	60 f7	60 f7	60 f7	72 f7
<b>S7</b>	35 f7	35 f7	50 f7	50 f7	50 f7	62 f7
<b>S8</b>	24	24	32	32	32	40
<b>S9</b>	M6	M6	M10	M10	M10	M10
<b>S10</b>	13	13	20	20	20	22
<b>S11</b>	120°	120°	120°	120°	120°	120°

RE - RA						
	110	210	310	510	610	810
<b>Su1</b>	A40x36 DIN5482	A40x36 DIN5482	A58x53 DIN5482	A58x53 DIN5482	A58x53 DIN5482	A70x64 DIN5482
<b>Su2</b>	Ø42 H7	Ø42 H7	Ø60 H7	Ø60 H7	Ø60 H7	Ø72 H7
<b>Su3</b>	6	6	7	7	7	11
<b>Su4</b>	6	6	10	10	10	10
<b>Su5</b>	20.5	20.5	25	25	25	29
<b>Su6</b>	Ø42 H7	Ø42 H7	Ø60 H7	Ø60 H7	Ø60 H7	Ø72 H7
<b>Su7</b>	49	49	69	69	69	80
<b>Su8</b>	Ø52	Ø52	Ø72	Ø72	Ø72	Ø80
<b>Su9</b>	1	1	1	1	1	1
<b>Su10</b>	1	1	1	1	1	1

RE - RA							
	stages	110	210	310	510	610	810
<b>A1</b>		186	186	244	244	244	295
<b>F0</b>		185	185	222	222	222	280
<b>F2</b>		110 h7	110 h7	150 f7	150 f7	150 f7	200 f7
<b>F3</b>		165	165	195	195	195	250
<b>F4</b>		5	5	13.5	13.5	13.5	10.5
<b>F5</b>		12	12	16	16	16	18
<b>F6</b>		Ø10.5	Ø10.5	Ø12.5	Ø12.5	Ø12.5	Ø15
		M... - 12.9					
<b>F7</b>		M10	M10	M12	M12	M12	M14
<b>F8</b>		45°	45°	36°	36°	36°	30°
<b>F8</b>		22.5°	22.5°	—	—	—	—
<b>FA1</b>		6.5	6.5	15	15	15	40
<b>FL</b>	1	95	107	133	151	151	162.5
	2	138	150	185.5	215.5	209.5	229.5
	3	181	193	228.5	258.5	262	282
	4	224	236	271.5	301.5	305	325
<b>FL7</b>	2	176	188	255	273	273	304.5
	3	219	231	266.5	296.5	331.5	351.5
<b>FL8</b>	2	250.5	262.5	346	364	364	412.5
	3	293.5	305.5	341	371	422.5	442.5
<b>T3</b>	2	113.8	113.8	171.5	171.5	171.5	277
	3	113.8	113.8	113.8	113.8	171.5	171.5
<b>T4</b>	2	184	184	183	183	183	242
	3	184	184	184	184	183	183
	4	184	184	184	184	184	184

**110 - 210  
310 - 510**

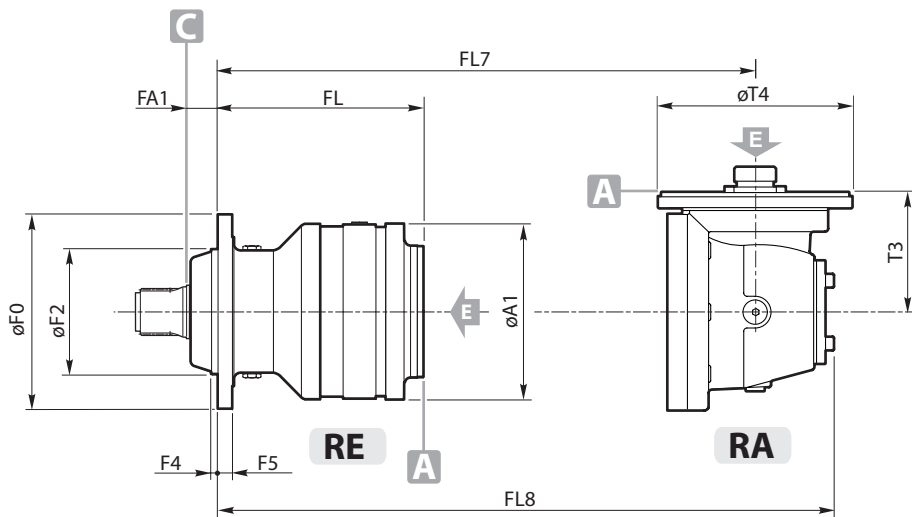
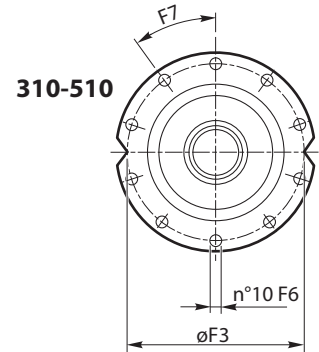
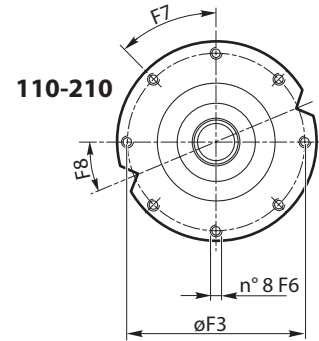
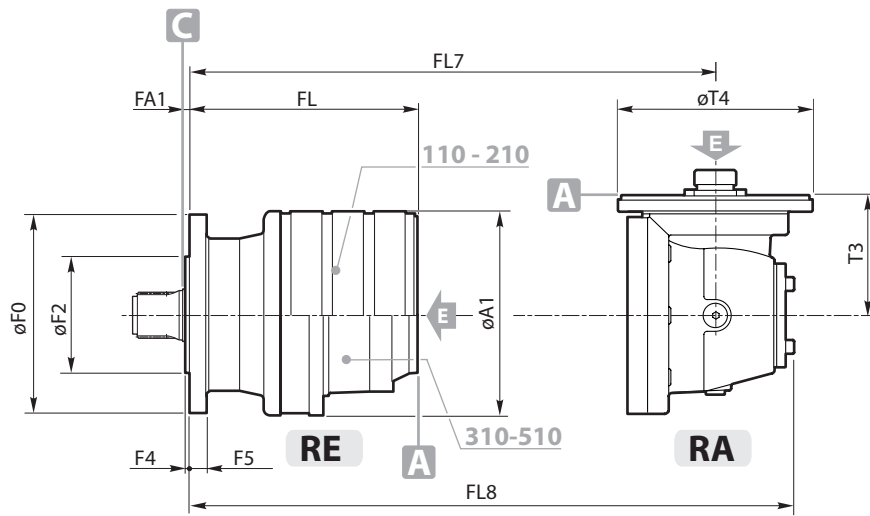

**610**

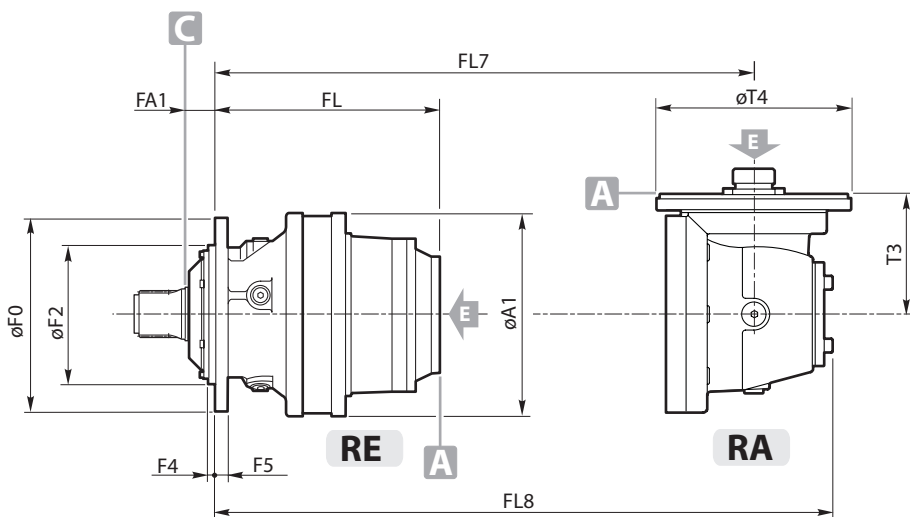
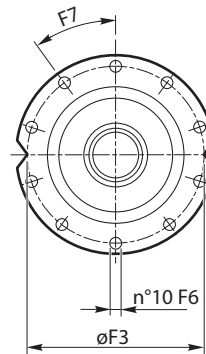

**810**

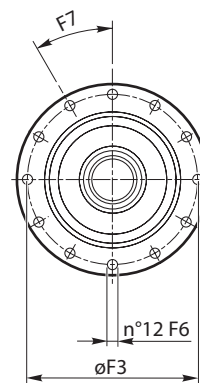

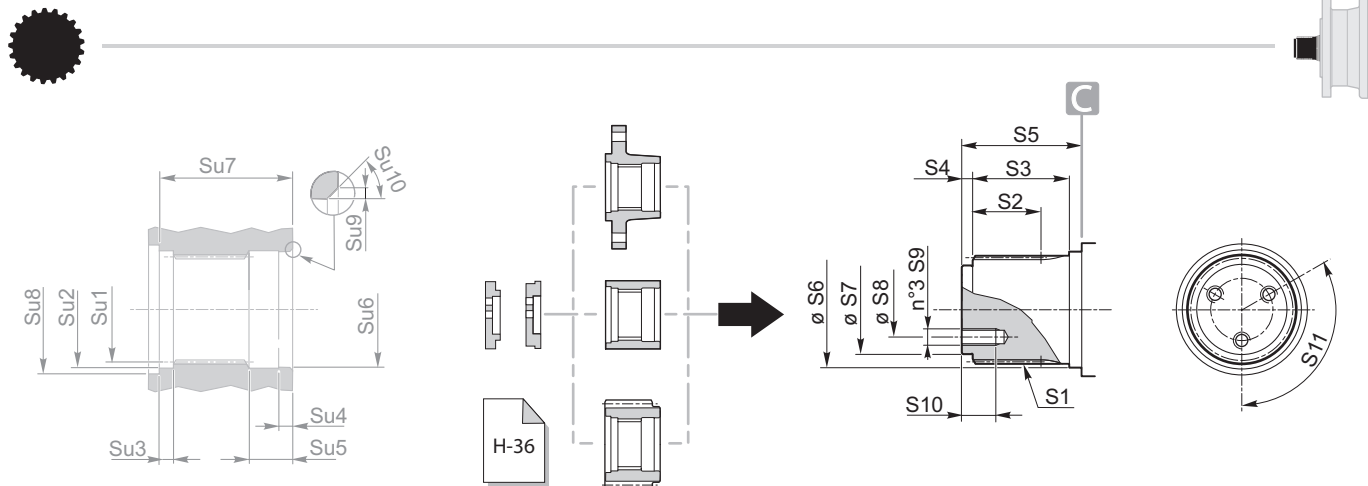

RE - RA							
	110	210	310	510	610	810	1020
<b>S1</b>	B40x36 DIN5482	B40x36 DIN5482	B58x53 DIN5482	B58x53 DIN5482	B58x53 DIN5482	B70x64 DIN5482	B70x64 DIN5482
<b>S2</b>	30	30	37	37	37	51	51
<b>S3</b>	43	43	50	50	50	70	70
<b>S4</b>	5	5	8	8	8	10	10
<b>S5</b>	55	55	68.5	68.5	68.5	90	90
<b>S6</b>	42 f7	42 f7	60 f7	60 f7	60 f7	72 f7	72 f7
<b>S7</b>	35 f7	35 f7	50 f7	50 f7	50 f7	62 f7	62 f7
<b>S8</b>	24	24	32	32	32	40	40
<b>S9</b>	M6	M6	M10	M10	M10	M10	M10
<b>S10</b>	13	13	20	20	20	22	22
<b>S11</b>	120°	120°	120°	120°	120°	120°	120°

RE - RA								
	stages	110	210	310	510	610	810	1020
<b>P1</b>		20	20	28	28	28	35	35
<b>P2</b>		132	132	180	180	180	225	225
<b>P3</b>		20	20	28	28	28	35	35
<b>P4</b>		172	172	236	236	236	295	295
<b>P5</b>		134	134	180	180	180	206	206
<b>P6</b>		190	190	250	250	250	300	300
<b>P7</b>		230	230	310	310	310	370	370
<b>P8</b>		Ø14	Ø14	Ø22	Ø22	Ø22	Ø26	Ø26
		M... - 12.9						
<b>P9</b>		M12	M12	M20	M20	M20	M24	M24
<b>P10</b>		23	23	26.5	26.5	26.5	36	36
<b>P11</b>		125	125	160	160	160	200	200
<b>P12</b>		218	218	282	282	282	347.5	347.5
<b>P13</b>		—	—	21	21	21	45	45
<b>PA1</b>		—	—	21	21	21	45	45
<b>PL</b>	1	101.5	113.5	148	166	166	225	242
	2	144.5	156.5	200.5	230.5	224.5	292	327
	3	187.5	199.5	243.5	273.5	277	344.5	391.5
	4	230.5	242.5	286.5	316.5	320	387.5	434.5
<b>PL7</b>	2	182.5	194.5	297	315	288	367	384
	3	225.5	237.5	281.5	311.5	346.5	414	449
	4	268.5	280.5	324.5	354.5	358	425.5	472.5
<b>PL8</b>	2	257	269	361	379	379	475	492
	3	300	312	356	386	437.5	505	540
	4	343	355	399	429	432.5	500	547
<b>T3</b>	2	113.8	113.8	171.5	171.5	171.5	277	277
	3	113.8	113.8	113.8	113.8	171.5	171.5	171.5
	4	113.8	113.8	113.8	113.8	113.8	113.8	113.8
<b>T4</b>	2	184	184	183	183	183	242	242
	3	184	184	184	184	183	183	183
	4	184	184	184	184	184	184	184

RE - RA							
	110	210	310	510	610	810	1020
<b>Su1</b>	A40x36 DIN5482	A40x36 DIN5482	A58x53 DIN5482	A58x53 DIN5482	A58x53 DIN5482	A70x64 DIN5482	A70x64 DIN5482
<b>Su2</b>	Ø42 H7	Ø42 H7	Ø60 H7	Ø60 H7	Ø60 H7	Ø72 H7	Ø72 H7
<b>Su3</b>	6	6	7	7	7	11	11
<b>Su4</b>	6	6	10	10	10	10	10
<b>Su5</b>	20.5	20.5	25	25	25	29	29
<b>Su6</b>	Ø42 H7	Ø42 H7	Ø60 H7	Ø60 H7	Ø60 H7	Ø72 H7	Ø72 H7
<b>Su7</b>	49	49	69	69	69	80	80
<b>Su8</b>	Ø52	Ø52	Ø72	Ø72	Ø72	Ø80	Ø80
<b>Su9</b>	1	1	1	1	1	1	1
<b>Su10</b>	1	1	1	1	1	1	1

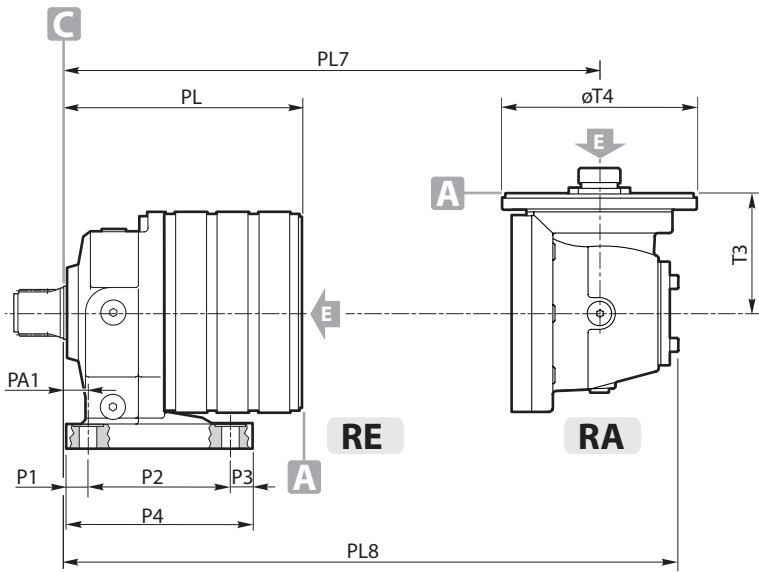

**110 - 210**

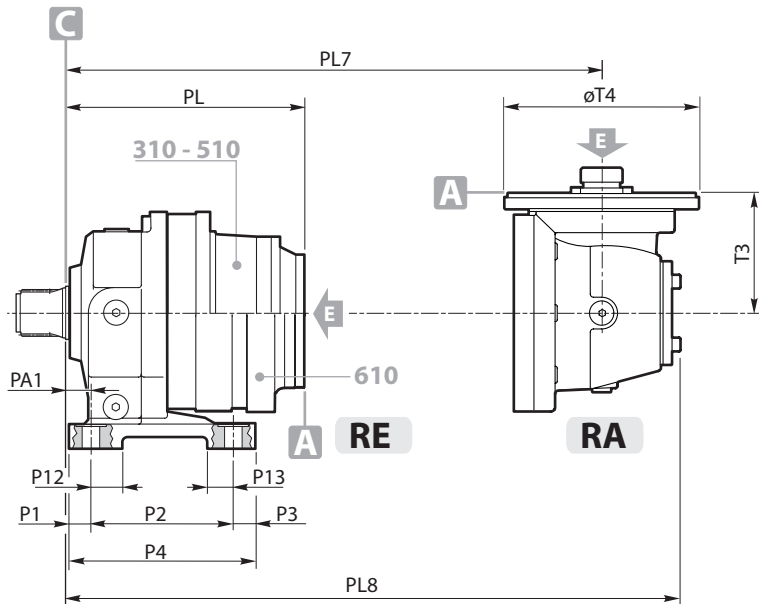
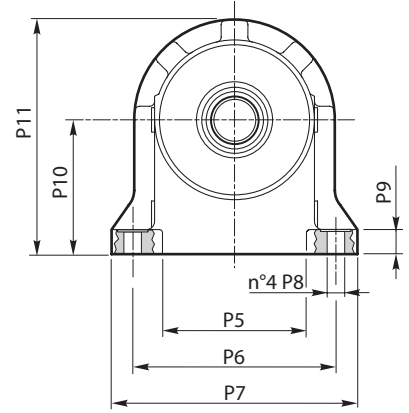

**310 - 510  
610**

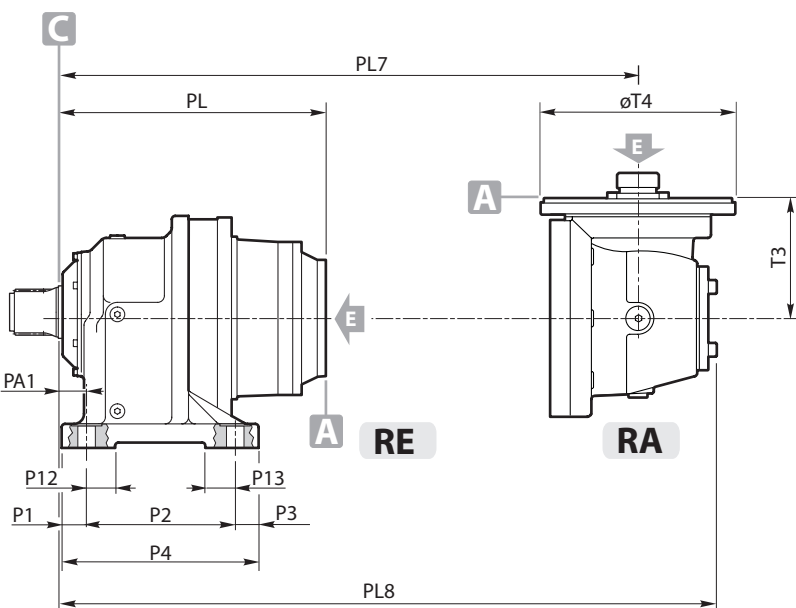
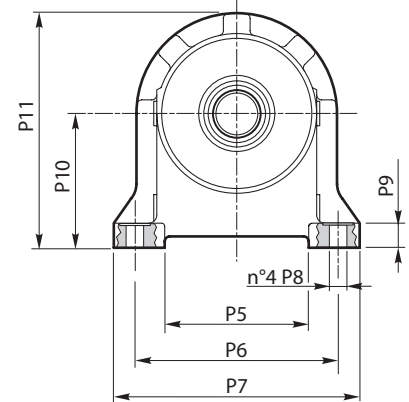

**810 - 1020**

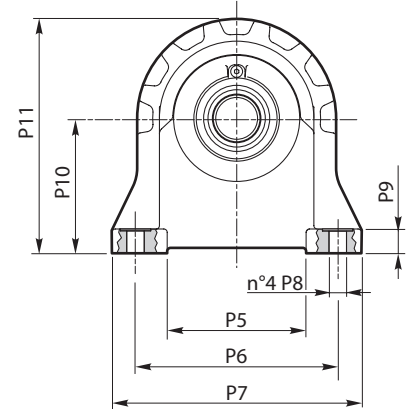

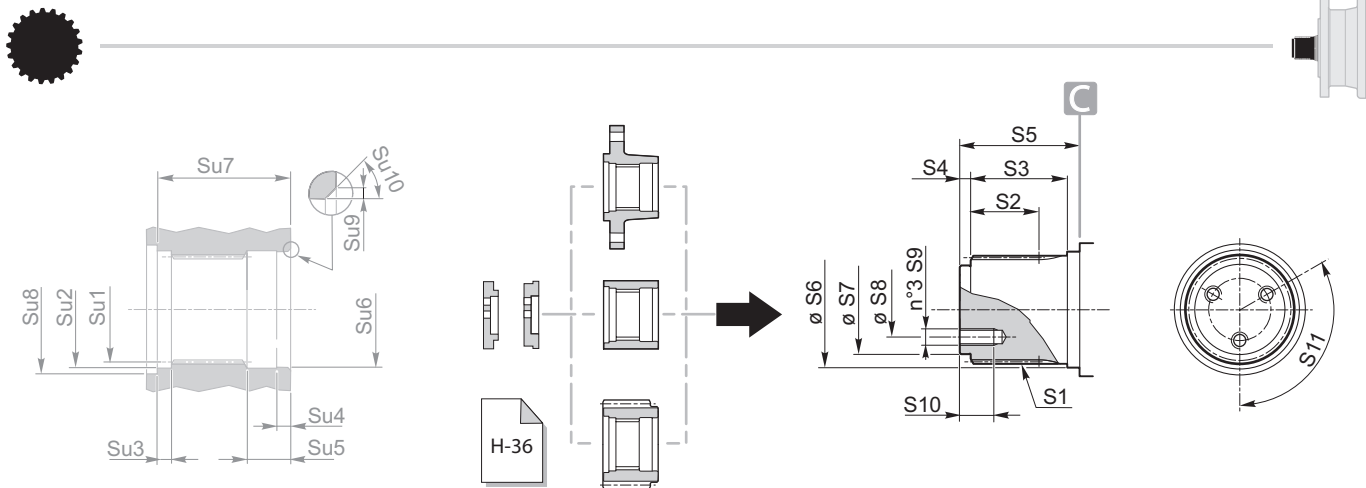

RE - RA						
	110	210	240	310	510	610
<b>Su1</b>	A40x36 DIN5482	A40x36 DIN5482	A58x53 DIN5482	A58x53 DIN5482	A58x53 DIN5482	A58x53 DIN5482
<b>Su2</b>	42 H7	42 H7	60 H7	60 H7	60 H7	60 H7
<b>Su3</b>	7	7	7	7	7	7
<b>Su4</b>	6	6	10	10	10	10
<b>Su5</b>	20.5	20.5	25	25	25	25
<b>Su6</b>	42 H7	42 H7	60 H7	60 H7	60 H7	60 H7
<b>Su7</b>	62.5	62.5	69	69	69	69
<b>Su8</b>	51	51	72	72	72	72
<b>Su9</b>	1	1	1	1	1	1
<b>Su10</b>	1	1	1	1	1	1

RE - RA						
	110	210	240	310	510	610
<b>S1</b>	B40x36 DIN5482	B40x36 DIN5482	B58x53 DIN5482	B58x53 DIN5482	B58x53 DIN5482	B58x53 DIN5482
<b>S2</b>	35	35	37	46	46	46
<b>S3</b>	50	50	50	60	60	60
<b>S4</b>	7	7	8	8	8	8
<b>S5</b>	62	62	68.5	78	78	78
<b>S6</b>	42 f7	42 f7	60 f7	60 f7	60 f7	60 f7
<b>S7</b>	35 f7	35 f7	50 f7	50 f7	50 f7	50 f7
<b>S8</b>	24	24	32	32	32	32
<b>S9</b>	M6	M6	M10	M10	M10	M10
<b>S10</b>	13	13	20	20	20	20
<b>S11</b>	120°	120°	120°	120°	120°	120°

RE - RA																	
	stages	110				210				240		310		510		610	
		TS	T1S	TRS	TR1S	TS	T1S	TRS	TR1S	TS	TRS	TS	TLS	TS	TLS	TS	TLS
<b>A1</b>		186	186	186	186	186	186	186	186	186	244	244	244	244	244	244	
<b>F0</b>		219	219	219	219	219	219	219	219	219	272	272	272	272	272	272	
<b>F2</b>		155 h7	150 f7	155 h7	150 f7	155 h7	150 f7	155 h7	150 f7	150 f7	155 f7	175 h8	175 h8	175 h8	175 h8	175 h8	
<b>F3</b>		194	195	194	195	194	195	194	195	195	194	245	245	245	245	245	
<b>F4</b>		7	7	10	10	7	7	10	10	7	10	12	9	12	9	12	
<b>F5</b>		15	15	15	15	15	15	15	15	15	20	20	20	20	20	20	
<b>F6</b>		Ø11	Ø13	Ø11	Ø13	Ø11	Ø13	Ø11	Ø13	Ø12.5	Ø11	Ø12.5	Ø12.5	Ø12.5	Ø12.5	Ø12.5	
		M. - 12.9															
<b>F7</b>		36°	36°	36°	36°	36°	36°	36°	36°	36°	36°	36°	36°	36°	36°	36°	
<b>FA1</b>		13	13	30	30	13	13	30	30	13	30	39	39	39	39	39	
<b>FL</b>	1	102	102	85	85	114	114	97	97	114	97	157	157	175	175	175	
	2	145	145	128	128	157	157	140	140	157	140	209.5	209.5	239.5	239.5	233.5	
	3	188	188	171	171	200	200	183	183	200	183	252.5	252.5	282.5	282.5	286	
	4	231	231	214	214	243	243	226	226	243	226	295.5	295.5	325.5	325.5	329	
<b>FL7</b>	2	183	183	166	166	195	195	178	178	195	178	279	279	297	297	297	
	3	226	226	209	209	238	238	221	221	238	221	290.5	290.5	320.5	320.5	355.5	
	4	269	269	252	252	281	281	264	264	281	264	333.5	333.5	363.5	363.5	367	
<b>FL8</b>	2	257.5	257.5	240.5	240.5	269.5	269.5	252.5	252.5	269.5	252.5	370	370	388	388	388	
	3	300.5	300.5	283.5	283.5	312.5	312.5	295.5	295.5	312.5	295.5	365	365	395	395	446.5	
	4	343.5	343.5	326.5	326.5	355.5	355.5	338.5	338.5	355.5	338.5	408	408	438	438	441.5	
<b>T3</b>	2	113.8	113.8	113.8	113.8	113.8	113.8	113.8	113.8	113.8	113.8	171.5	171.5	171.5	171.5	171.5	
	3	113.8	113.8	113.8	113.8	113.8	113.8	113.8	113.8	113.8	113.8	113.8	113.8	113.8	113.8	113.8	
	4	113.8	113.8	113.8	113.8	113.8	113.8	113.8	113.8	113.8	113.8	113.8	113.8	113.8	113.8	113.8	
<b>T4</b>	2	184	184	184	184	184	184	184	184	184	184	183	183	183	183	183	
	3	184	184	184	184	184	184	184	184	184	184	184	184	184	183	183	
	4	184	184	184	184	184	184	184	184	184	184	184	184	184	184	184	

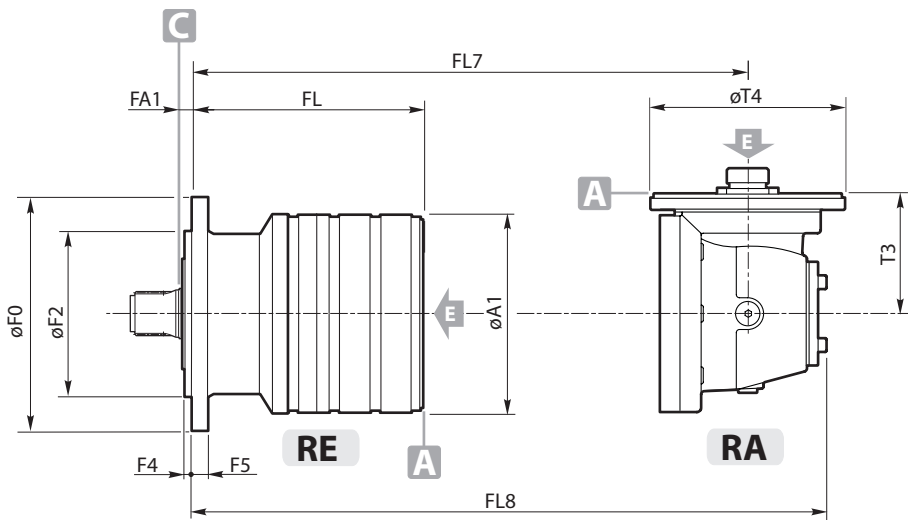

**110 ÷ 240**

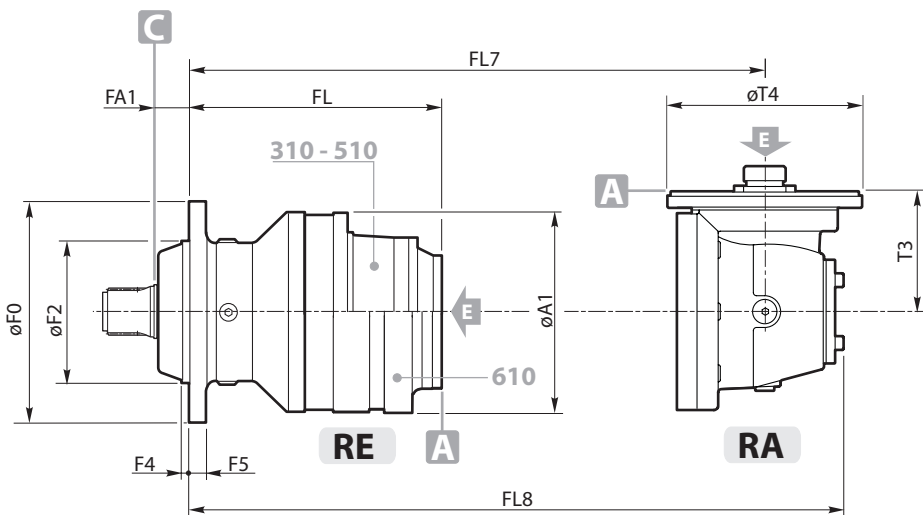
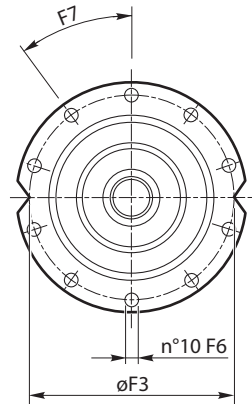

**310 - 510  
610**

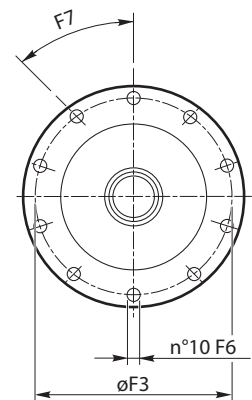

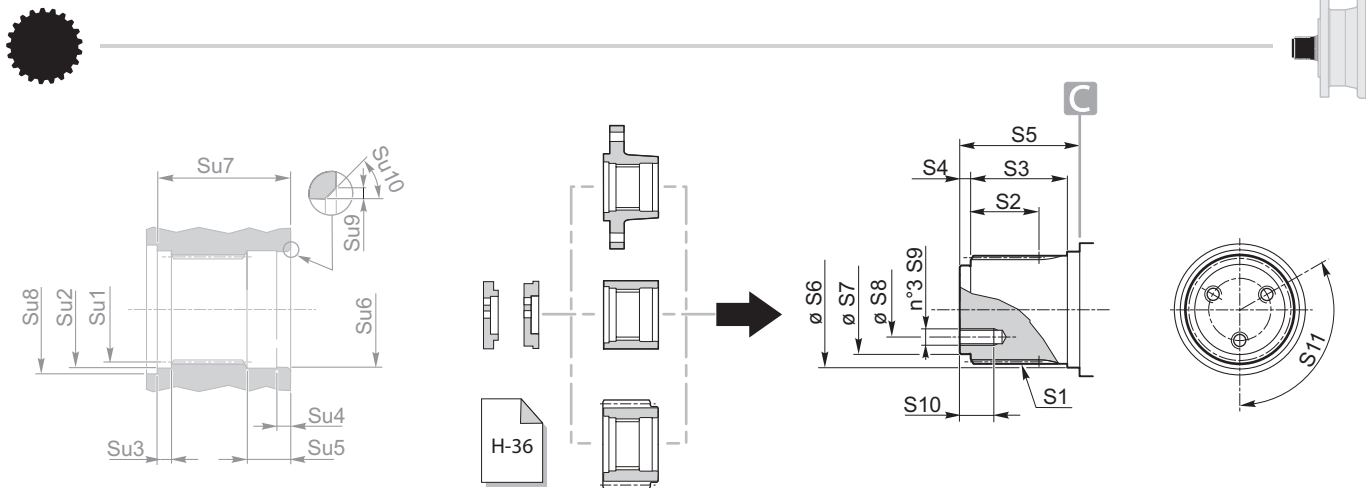

RE - RA				
	810	1020	1520	2000 2000L
<b>S1</b>	B70x64 DIN5482	B80x74 DIN5482	B80x74 DIN5482	B80x74 DIN5482
<b>S2</b>	51	50	50	50
<b>S3</b>	70	70	70	70
<b>S4</b>	10	10	10	10
<b>S5</b>	90	90	90	90
<b>S6</b>	72 f7	85 f7	85 f7	85 f7
<b>S7</b>	62 f7	70 f7	70 f7	70 f7
<b>S8</b>	40	45	45	45
<b>S9</b>	M10	M10	M10	M10
<b>S10</b>	22	25	25	25
<b>S11</b>	120°	120°	120°	120°

RE - RA				
	810	1020	1520	2000 2000L
<b>Su1</b>	A70x64 DIN5482	A80x74 DIN5482	A80x74 DIN5482	A80x74 DIN5482
<b>Su2</b>	72 H7	85 H7	85 H7	85 H7
<b>Su3</b>	10	10.5	10.5	10.5
<b>Su4</b>	11	10.5	10.5	10.5
<b>Su5</b>	29	30.5	30.5	30.5
<b>Su6</b>	72 H7	85 H7	85 H7	85 H7
<b>Su7</b>	90	90.5	90.5	90.5
<b>Su8</b>	82	100	100	100
<b>Su9</b>	1	1	1	1
<b>Su10</b>	1	1	1	1

RE - RA						
	stages	810	1020	1520	2000	2000L
<b>A1</b>		295	295	350	350	350
<b>F0</b>		280	325	325	325	325
<b>F2</b>		200 f7	230 f7	230 f7	230 f7	230 f7
<b>F3</b>		250	295	295	295	295
<b>F4</b>		10.5	15	15	15	15
<b>F5</b>		22	25	28	28	28
<b>F6</b>		Ø15	Ø17	Ø17	Ø17	Ø17
		M... - 12,9				
		M14	M16	M16	M16	M16
<b>F7</b>		30°	36°	36°	36°	36°
<b>FA1</b>		40	36	36	36	36
<b>FL</b>	1	185	237	240	240	240
	2	252	322	333	333	333
	3	304.5	386.5	397.5	391.5	397.5
	4	347.5	429.5	440	444	440
<b>FL7</b>	2	326.5	379	446	446	446
	3	374	444	455	455	455
<b>FL8</b>	4	385.5	467.5	478.5	513.5	478.5
	2	435	487	574	574	574
<b>T3</b>	3	465	535	546	546	546
	4	460	542	553	604.5	553
<b>T4</b>	2	277	277	310	310	310
	3	171.5	171.5	171.5	171.5	171.5
<b>T3</b>	4	113.8	113.8	113.8	171.5	113.8
	2	242	242	293	293	293
<b>T4</b>	3	183	183	183	183	183
	4	184	184	184	183	184



**810**

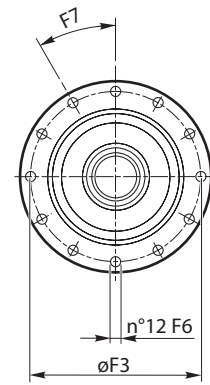
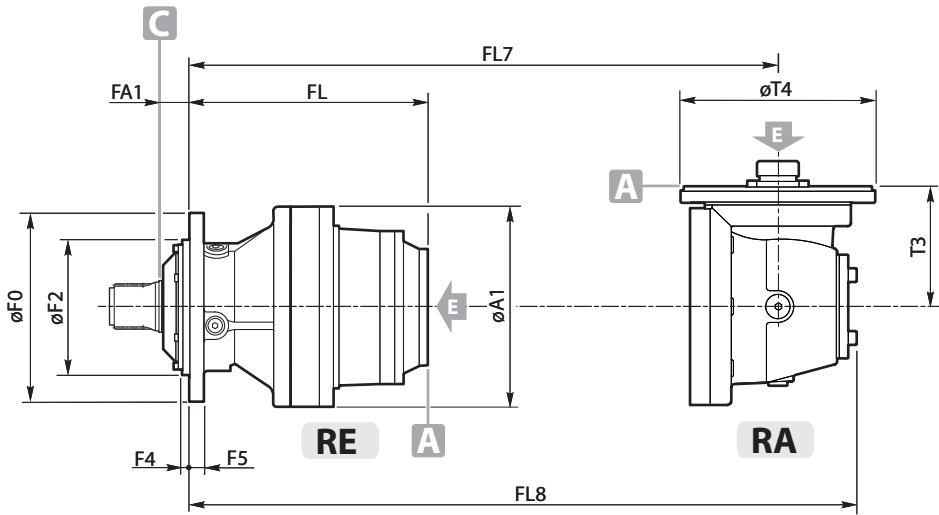

**1020 - 1520  
2000 - 2000L**

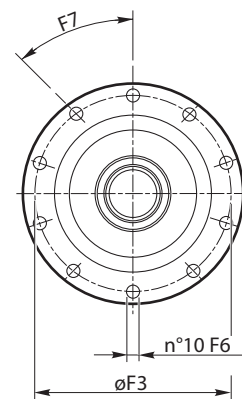
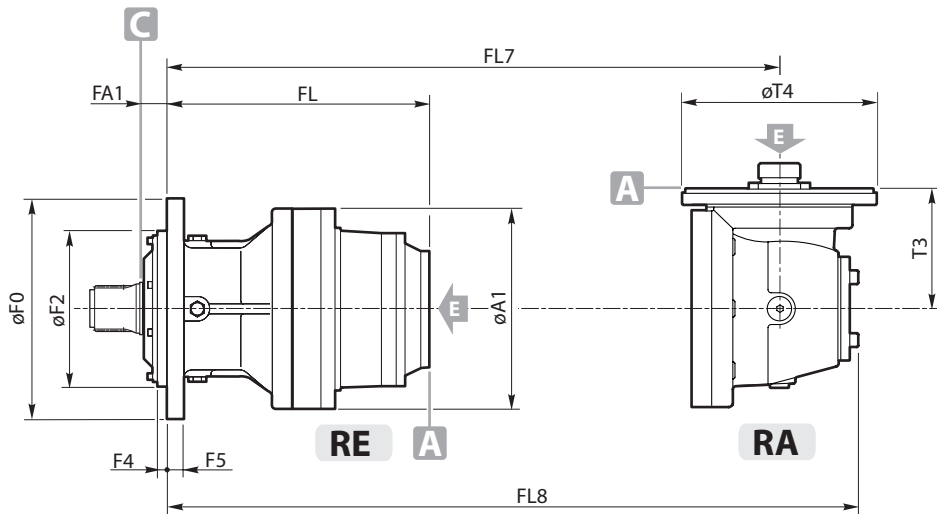

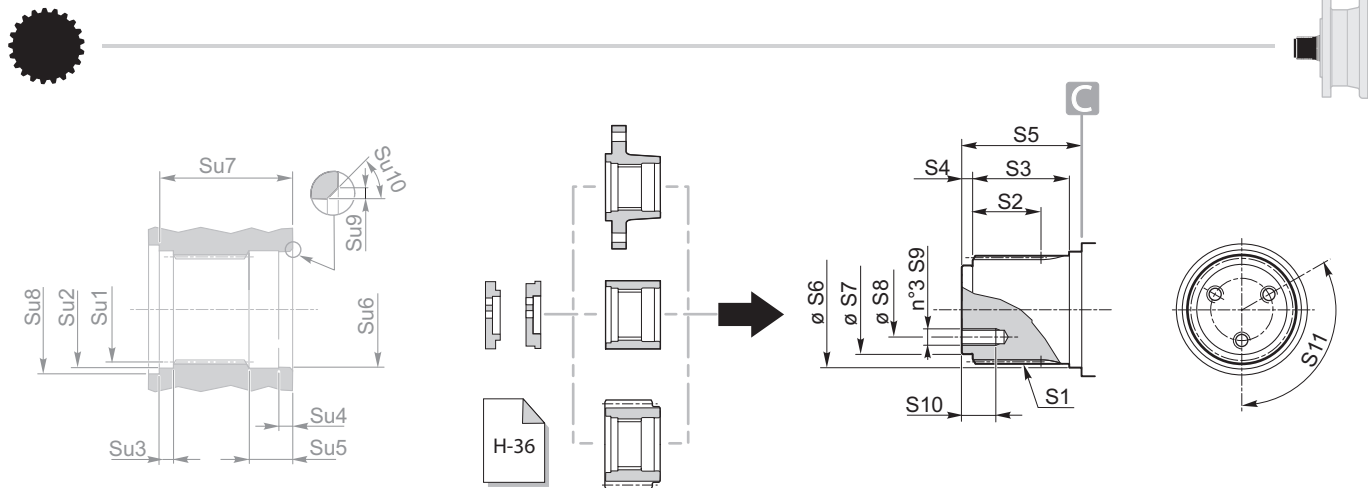

RE - RA						
	1520	2000 2000L	2520	3000	3510	4800
<b>S1</b>	B80x74 DIN 5482	B80x74 DIN 5482	B100x94 DIN 5482	B100x94 DIN 5482	W120x3x8f DIN 5480	W120x3x8f DIN 5480
<b>S2</b>	50	50	65	65	95	95
<b>S3</b>	70	70	85	85	111	111
<b>S4</b>	10	10	12	12	15	15
<b>S5</b>	90	90	110	110	136	136
<b>S6</b>	85 f7	85 f7	105 h7	105 h7	124 f7	124 f7
<b>S7</b>	70 f7	70 f7	85 h7	85 h7	90 f7	90 f7
<b>S8</b>	45	45	52	52	50	50
<b>S9</b>	M10	M10	M14	M14	M16	M16
<b>S10</b>	25	25	30	30	30	30
<b>S11</b>	120°	120°	120°	120°	120°	120°

RE - RA						
	1520	2000 2000L	2520	3000	3510	4800
<b>Su1</b>	A80x74 DIN 5482	A80x74 DIN 5482	A100x94 DIN 5482	A100x94 DIN 5482	N120x3x9H DIN 5480	N120x3x9H DIN 5480
<b>Su2</b>	85 H7	85 H7	105 H7	105 H7	130 H7	130 H7
<b>Su3</b>	10.5	10.5	12	12	28	28
<b>Su4</b>	10.5	10.5	13	13	12	12
<b>Su5</b>	30.5	30.5	33	33	29	29
<b>Su6</b>	85 H7	85 H7	105 H7	105 H7	124 H7	124 H7
<b>Su7</b>	90.5	90.5	110	110	150	150
<b>Su8</b>	100	100	116	116	132	132
<b>Su9</b>	1	1	1.5	1.5	3	3
<b>Su10</b>	1	1	1.5	1.5	3	3

RE - RA								
	stages	1520	2000	2000L	2520	3000	3510	4800
<b>A1</b>		350	350	350	409	409	452	452
<b>FA1</b>		169	169	169	180	180	109	109
<b>F2</b>		278 f7	278 f7	278 f7	340 f7	340 f7	390 f8	390 f8
<b>F3</b>		314	314	314	370	370	424	424
<b>F4</b>		10	10	10	17	17	15	15
<b>F5</b>		133	133	133	131	131	120	120
<b>F6</b>		Ø16.5	Ø16.5	Ø16.5	Ø17	Ø17	Ø17	Ø17
		M16	M16	M16	M16	M16	M16	M16
<b>F6A</b>		Ø12	Ø12	Ø12	Ø16	Ø16	—	—
<b>F7</b>		15°	15°	15°	12°	12°	20°	20°
<b>F7A</b>		30°	30°	30°	30°	30°	—	—
<b>F8</b>		15°	15°	15°	24°	24°	10°	10°
<b>FL</b>	1	107	107	107	98	98	85	85
	2	200	200	200	209	226	277	326
	3	264.5	258.5	264.5	276	311	362	419
	4	307.5	311	307.5	328.5	375.5	426.5	483.5
<b>FL7</b>	2	313	313	313	292	292	339	339
	3	322	322	322	351	368	419	532
<b>FL8</b>	2	441	441	441	420	420	529	529
	3	413	413	413	459	476	527	660
<b>G2</b>		225 f7	225 f7	225 f7	245 f7	245 f7	—	—
<b>G4</b>		104.5	104.5	104.5	142	142	—	—
<b>G5</b>		27.5	27.5	27.5	29	29	—	—
<b>H</b>		15	15	15	29	29	—	—
<b>T3</b>	2	310	310	310	310	310	432	432
	3	171	171	171	227	227	227	310
	4	113.8	171	113.8	171	171	171	171
<b>T4</b>	2	293	293	293	293	293	295	295
	3	183	183	183	242	242	242	293
	4	184	183	184	183	183	183	183

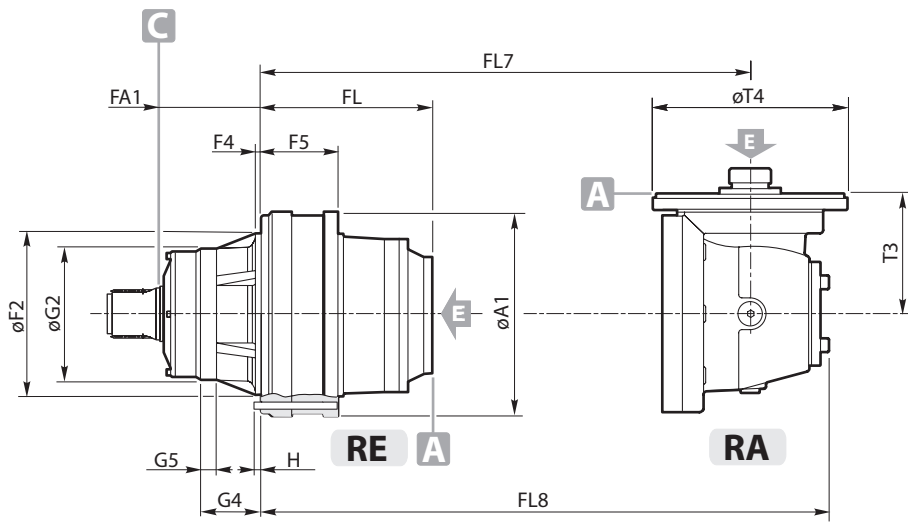

**1520 - 2000  
2000L**

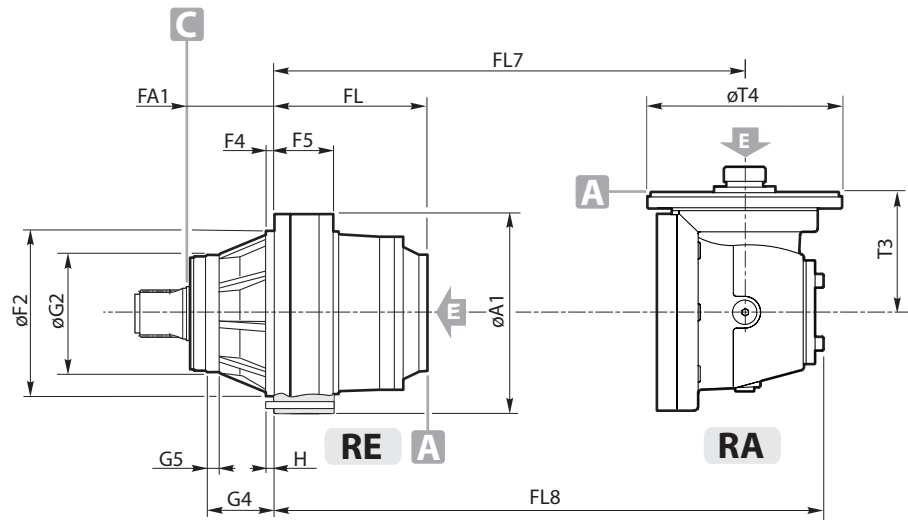
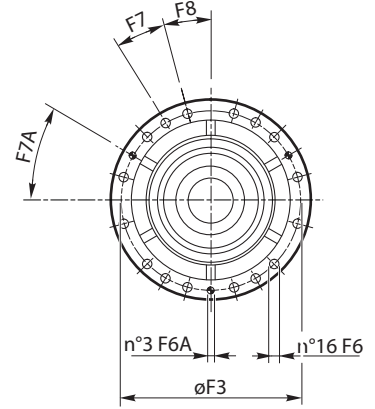

**2520 - 3000**

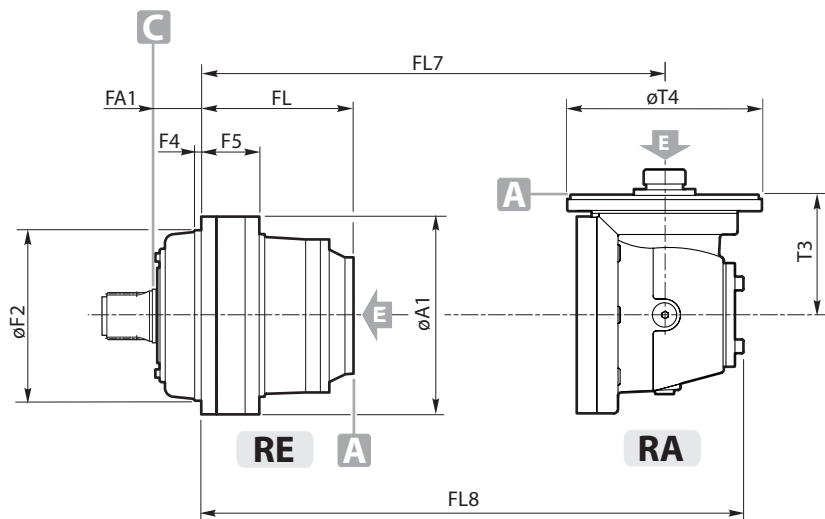
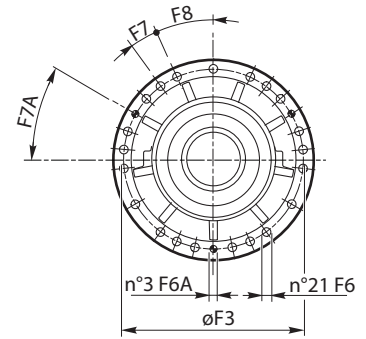

**3510 - 4800**

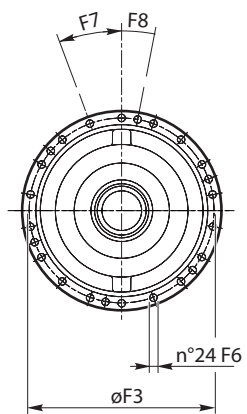

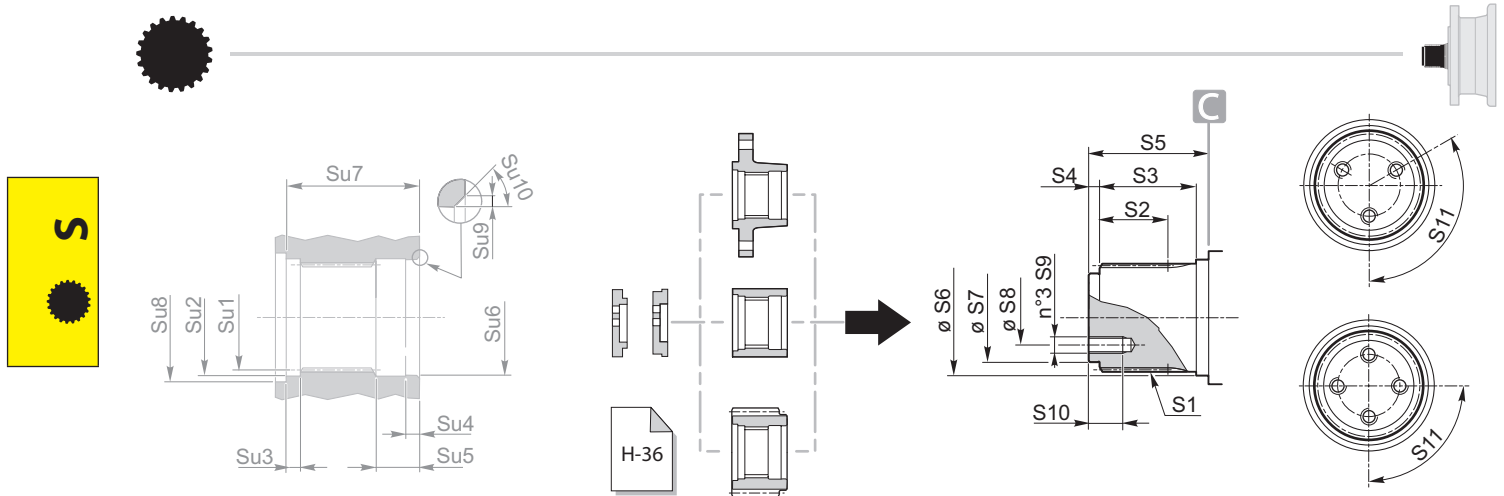

	RE - RA			GB - GBA	
	6000		8000	12010	16000
	HS	H6S	HS	HS	HS
<b>S1</b>	W120x3x8f DIN 5480	W150x5x8f DIN 5480	W150x5x8f DIN 5480	W170x5x8f DIN 5480	W170x5x8f DIN 5480
<b>S2</b>	85	107	107	110	110
<b>S3</b>	103	124	124	135	135
<b>S4</b>	10	12	12	15	15
<b>S5</b>	125	150	150	165	165
<b>S6</b>	120 h7	151 f7	151 f7	170 f7	170 f7
<b>S7</b>	100 h7	125 f7	125 f7	150 f7	150 f7
<b>S8</b>	70	80	80	110	110
<b>S9</b>	M16 (3)	M16 (3)	M16 (3)	M16 (4)	M16 (4)
<b>S10</b>	35	35	35	35	35
<b>S11</b>	120°	120°	120°	90°	90°

	RE - RA			GB - GBA	
	6000		8000	12010	16000
	HS	H6S	HS	HS	HS
<b>Su1</b>	N120x3x9H DIN 5480	N150x5x9H DIN 5480	N150x5x9H DIN 5480	N170x5x9H DIN 5480	N170x5x9H DIN 5480
<b>Su2</b>	120 H7	151 H7	151 H7	175 H7	175 H7
<b>Su3</b>	10.5	11	11	14	14
<b>Su4</b>	12	33	33	15	15
<b>Su5</b>	31	33	33	42	42
<b>Su6</b>	120 H7	151 H7	151 H7	170 H7	170 H7
<b>Su7</b>	124.5	150	150	163	163
<b>Su8</b>	137	172	172	200	200
<b>Su9</b>	3	3	3	3	3
<b>Su10</b>	3	3	3	3	3

	stages	RE - RA			GB - GBA	
		6000		8000	12010	16000
		HS	H6S	HS	HS	HS
<b>A1</b>		490	490	490	610	610
<b>F2</b>		410 f7	410 h8	410 h8	515 h8	515 h8
<b>F3</b>		445	445	445	560	560
<b>F4</b>		15	15	15	20	20
<b>F5</b>		187	178.5	181.5	230	230
<b>F6</b>		Ø19		Ø19	Ø25	Ø25
		M18		M18	M24	M24
<b>F7</b>		7°30'	7°30'	7°30'	15°	15°
<b>F8</b>		15°	15°	15°	7°30'	7°30'
<b>F9</b>		7°30'	7°30'	7°30'	7°30'	7°30'
<b>FA1</b>		226	126	126	145	145
<b>FL</b>	1	145	136.5	136.5	160.5	160.5
	2	313.5	305	390.5	410	427
	3	406.5	398	518.5	538	668
	4	465	456.5	603.5	623	761
	5	—	—	668	687.5	825.5
<b>FL7</b>	2	399	390.5	390.5	—	—
	3	519.5	511	584.5	604	681
	4	528.5	520	660.5	680	874
	5	—	—	—	745	883
<b>FL8</b>	2	589	580.5	580.5	—	—
	3	647.5	639	712.5	732	871
	4	619.5	611	768.5	788	1002
	5	—	—	—	836	974
<b>G2</b>		260 f7	—	—	—	—
<b>G4</b>		181	—	—	—	—
<b>G5</b>		33	—	—	—	—
<b>T3</b>	2	432	432	432	—	—
	3	310	310	310	310	432
	4	171	171	227	227	310
	5	—	—	—	171	171
<b>T4</b>	2	295	295	295	—	—
	3	293	293	293	293	295
	4	183	183	242	242	293
	5	—	—	—	183	183

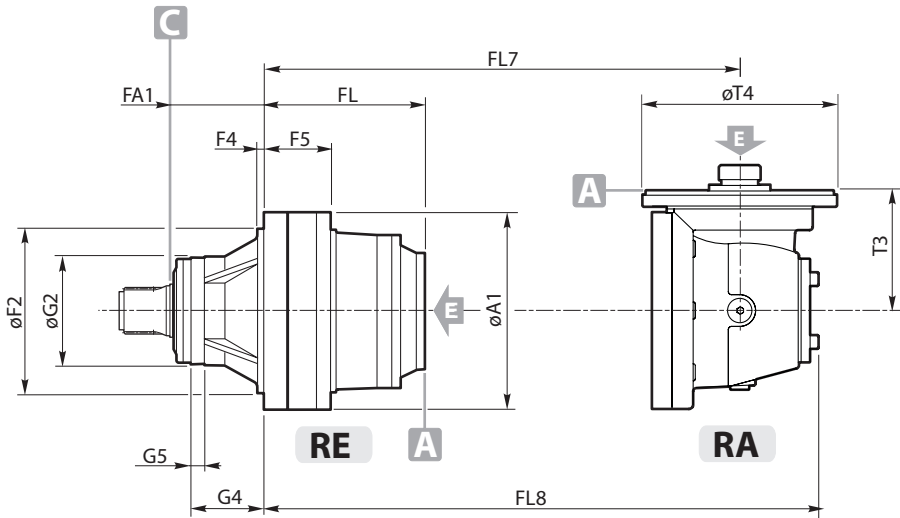

**HS 6000**

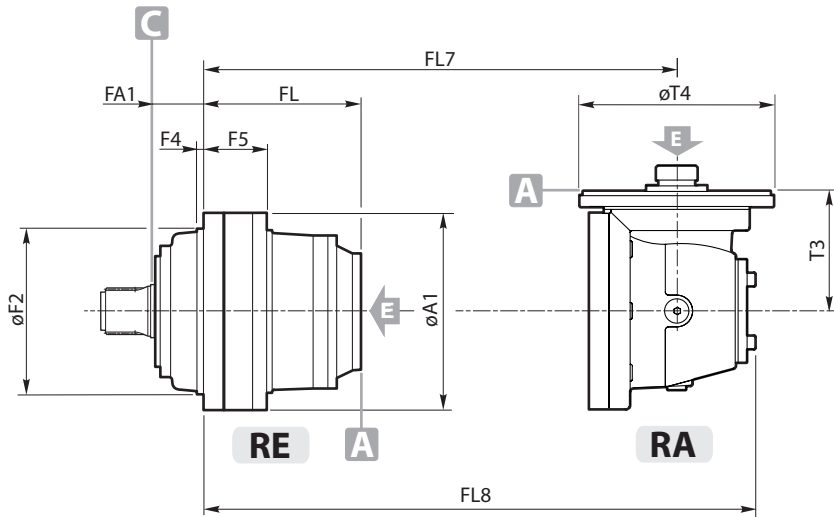
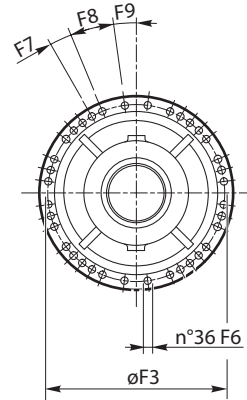

**H6S 6000**

**HS 8000**

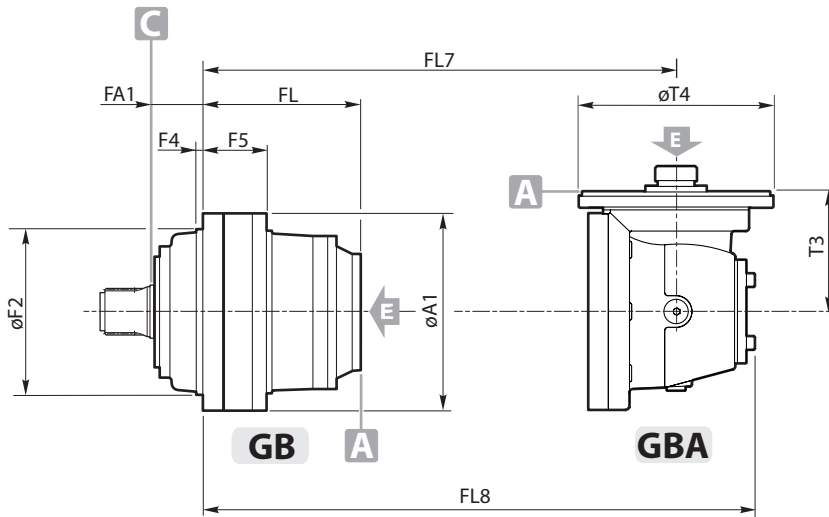
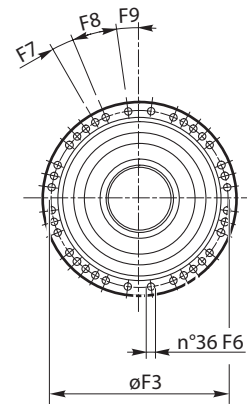

**HS 12010 - 16000**

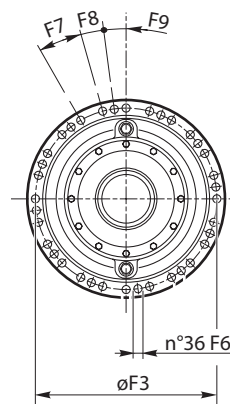

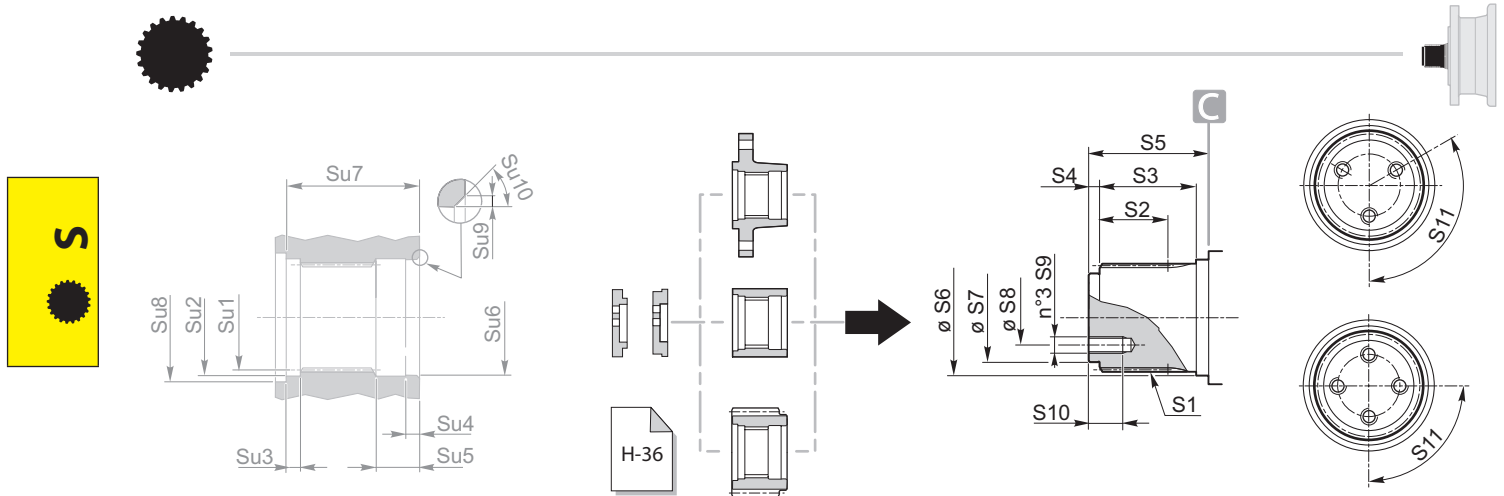

	RE - RA			GB - GBA	
	6000L		8000L	12010L	16000L
	HS	H6S	HS	HS	HS
<b>S1</b>	W120x3x8f DIN 5480	W150x5x8f DIN 5480	W150x5x8f DIN 5480	W170x5x8f DIN 5480	W170x5x8f DIN 5480
<b>S2</b>	85	107	107	110	110
<b>S3</b>	103	124	124	135	135
<b>S4</b>	10	12	12	15	15
<b>S5</b>	125	150	150	165	165
<b>S6</b>	120 h7	151 f7	151 f7	170 f7	170 f7
<b>S7</b>	100 h7	125 f7	125 f7	150 f7	150 f7
<b>S8</b>	70	80	80	110	110
<b>S9</b>	M16 (3)	M16 (3)	M16 (3)	M16 (4)	M16 (4)
<b>S10</b>	35	35	35	35	35
<b>S11</b>	120°	120°	120°	90°	90°

	RE - RA			GB - GBA	
	6000L		8000L	12010L	16000L
	HS	H6S	HS	HS	HS
<b>Su1</b>	N120x3x9H DIN 5480	N150x5x9H DIN 5480	N150x5x9H DIN 5480	N170x5x9H DIN 5480	N170x5x9H DIN 5480
<b>Su2</b>	120 H7	151 H7	151 H7	175 H7	175 H7
<b>Su3</b>	10.5	11	11	14	14
<b>Su4</b>	12	33	33	15	15
<b>Su5</b>	31	33	33	42	42
<b>Su6</b>	120 H7	151 H7	151 H7	170 H7	170 H7
<b>Su7</b>	124.5	150	150	163	163
<b>Su8</b>	137	172	172	200	200
<b>Su9</b>	3	3	3	3	3
<b>Su10</b>	3	3	3	3	3

	stages	RE - RA			GB - GBA	
		6000L		8000L	12010L	16000L
		HS	H6S	HS	HS	HS
<b>A1</b>		490	490	490	610	610
<b>F2</b>		410 f7	410 h8	410 h8	515 h8	515 h8
<b>F3</b>		445	445	445	560	560
<b>F4</b>		15	15	15	20	20
<b>F5</b>		187	178.5	181.5	230	230
<b>F6</b>		Ø19	Ø19	Ø19	Ø25	Ø25
		M... - 12.9		M... - 10.9		
<b>F7</b>		M18	M18	M18	M24	M24
<b>F8</b>		7°30'	7°30'	7°30'	15°	15°
<b>F9</b>		15°	15°	15°	7°30'	7°30'
<b>F9</b>		7°30'	7°30'	7°30'	7°30'	7°30'
<b>FA1</b>		226	126	126	145	145
<b>FL</b>	1	145	136.5	136.5	160.5	160.5
	2	313.5	305	390.5	410	427
	3	406.5	398	501.5	521	619
	4	471	462.5	568.5	588	704
	5	—	—	621	640.5	768.5
<b>FL7</b>	2	399	390.5	390.5	—	—
	3	519.5	511	584.5	604	681
	4	528.5	520	643.5	663	761
	5	—	—	—	710	826
<b>FL8</b>	2	589	580.5	580.5	—	—
	3	647.5	639	712.5	732	871
	4	619.5	611	751.5	771	869
	5	—	—	—	801	917
<b>G2</b>		260 f7	—	—	—	—
<b>G4</b>		181	—	—	—	—
<b>G5</b>		33	—	—	—	—
<b>T3</b>	2	432	432	432	/	/
	3	310	310	310	310	432
	4	171	171	227	227	227
	5	—	—	—	171	171
	<b>T4</b>	2	295	295	295	—
3		293	293	293	293	295
4		183	183	242	242	242
5		—	—	—	183	183

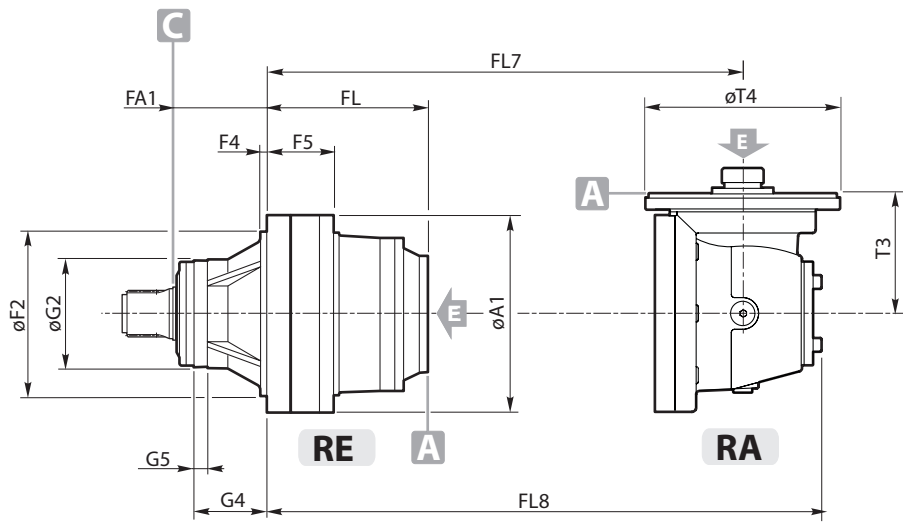

**HS 6000L**

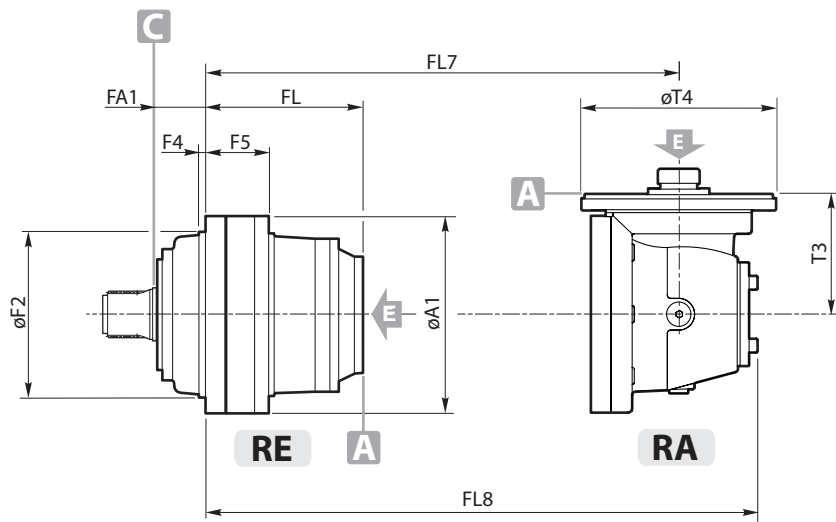
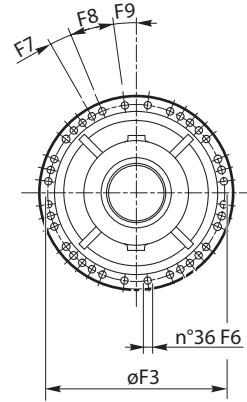

**H6S 6000L**

**HS 8000L**

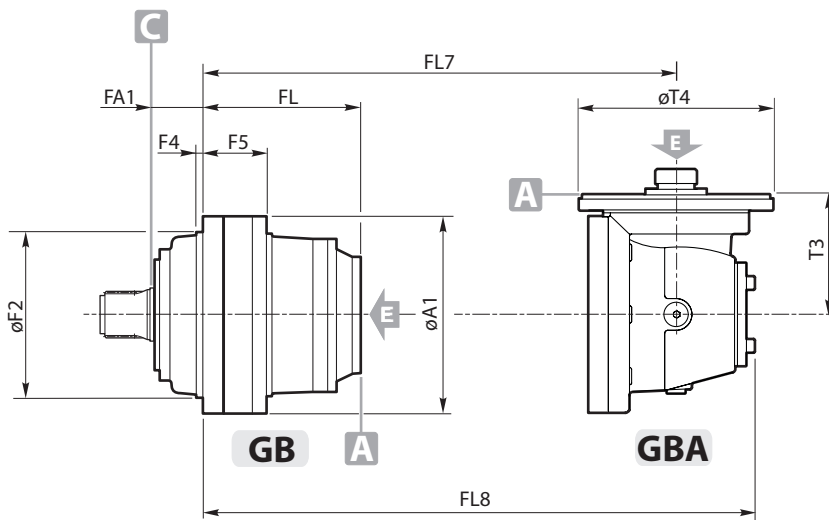
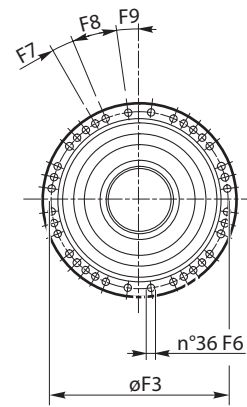

**HS 12010L-16000L**

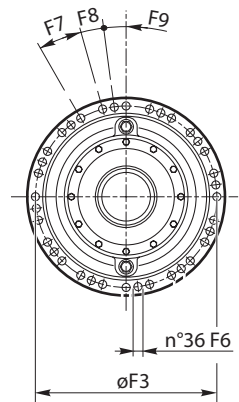

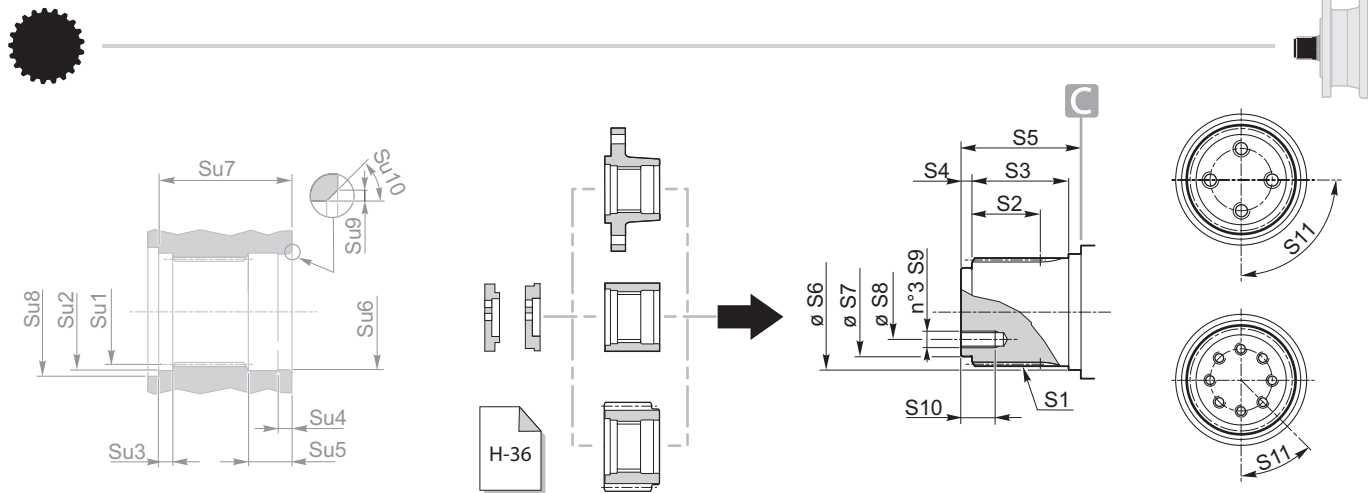

RE - RA					
	21000	26000	31000	40000	45000
<b>S1</b>	W220x5x8f DIN 5480	W220x5x8f DIN 5480	W280x5x8f DIN 5480	W280x5x8f DIN 5480	W280x5x8f DIN 5480
<b>S2</b>	140	140	175	175	175
<b>S3</b>	167	167	210	210	210
<b>S4</b>	20	20	25	25	25
<b>S5</b>	210	210	260	260	260
<b>S6</b>	220 f7	220 f7	283 f7	283 f7	283 f7
<b>S7</b>	200 f7	200 f7	260 f7	260 f7	260 f7
<b>S8</b>	150	150	200	200	200
<b>S9</b>	M24(x4)	M24(x4)	M24(x8)	M24(x8)	M24(x8)
<b>S10</b>	50	50	50	50	50
<b>S11</b>	90°	90°	45°	45°	45°

RE - RA					
	21000	26000	31000	40000	45000
<b>Su1</b>	N220x5x9H DIN 5480	N220x5x9H DIN 5480	N280x5x9H DIN 5480	N280x5x9H DIN 5480	N280x5x9H DIN 5480
<b>Su2</b>	230 H7	230 H7	300 H7	300 H7	300 H7
<b>Su3</b>	16	16	24.5	24.5	24.5
<b>Su4</b>	23	23	25	25	25
<b>Su5</b>	51.5	51.5	65	65	65
<b>Su6</b>	220 H7	220 H7	283 H7	283 H7	283 H7
<b>Su7</b>	205	205	260	260	260
<b>Su8</b>	262	262	302	302	302
<b>Su9</b>	3	3	3	3	3
<b>Su10</b>	3	3	3	3	3

RE - RA						
	stages	21000	26000	31000	40000	45000
<b>A1</b>		710	710	870	870	870
<b>F2</b>		600 h8	600 h8	760 h8	760 h8	760 h8
<b>F3</b>		660	660	810	810	810
<b>F4</b>		23.5	23.5	35	35	35
<b>F5</b>		196	216	250	290	290
<b>F6</b>		Ø28	Ø28	Ø32	Ø32	Ø32
		M... - 10.9				
<b>F7</b>		M27	M27	M30	M30	M30
		10°	10°	10°	10°	10°
<b>FA1</b>		180	180	225	225	225
<b>FL</b>	1	138	158	180	220	220
	2	443	463	588.5	628.5	628.5
	3	611.5	717	838	878	895
	4	704.5	845	966	1006	1136
	5	763	930	1051	1091	1229
<b>FL7</b>	3	697	717	/	/	/
	4	817.5	911	1032	1072	1149
<b>FL8</b>	5	826.5	987	1108	1148	1342
	3	887	907	/	/	/
<b>T3</b>	4	945.5	1039	1160	1200	1339
	5	917.5	1095	1216	1256	1470
<b>T4</b>	3	432	432	/	/	/
	4	310	310	310	310	432
<b>T4</b>	5	171	227	227	227	310
	3	295	295	/	/	/
	4	293	293	293	293	295
	5	183	242	242	242	293

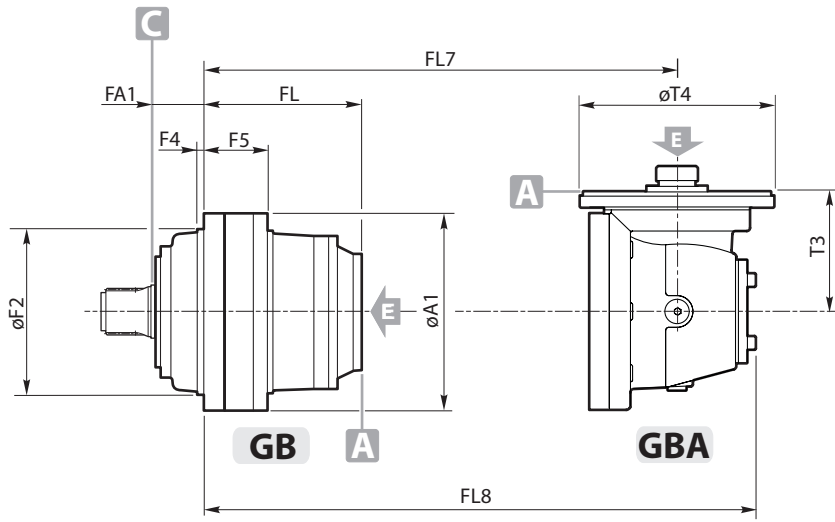

**21000 ÷ 45000**

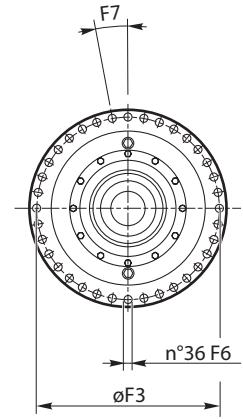

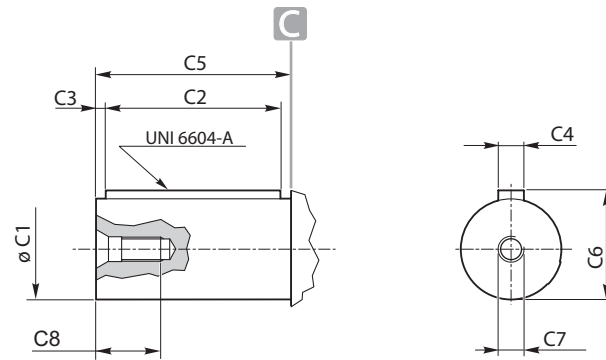
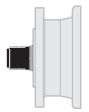

		RE - RA					
		110	210	310	510	610	810
<b>NC</b>	<b>C1</b>	38 h7	38 h7	50 h7	50 h7	50 h7	80 h6
	<b>C2</b>	50	50	90	90	90	110
	<b>C3</b>	4	4	8	8	8	8
	<b>C4</b>	10	10	14	14	14	22
	<b>C5</b>	58	58	105	105	105	130
	<b>C6</b>	41	41	53.5	53.5	53.5	85
	<b>C7</b>	M12	M12	M14	M14	M14	M20
	<b>C8</b>	20	20	30	30	30	45

		RE - RA					
		110	210	310	510	610	810
<b>NK</b>	<b>C1</b>	42 h7	42 h7	60 h7	60 h7	60 h7	—
	<b>C2</b>	70	70	90	90	90	—
	<b>C3</b>	6	6	8	8	8	—
	<b>C4</b>	12	12	18	18	18	—
	<b>C5</b>	82	82	105	105	105	—
	<b>C6</b>	45	45	64	64	64	—
	<b>C7</b>	M16	M16	M16	M16	M16	—
	<b>C8</b>	30	30	30	30	30	—

		RE - RA					
		110	210	310	510	610	810
<b>NK1</b>	<b>C1</b>	—	—	65 h7	65 h7	65 h7	—
	<b>C2</b>	—	—	90	90	90	—
	<b>C3</b>	—	—	8	8	8	—
	<b>C4</b>	—	—	18	18	18	—
	<b>C5</b>	—	—	105	105	105	—
	<b>C6</b>	—	—	69	69	69	—
	<b>C7</b>	—	—	M20	M20	M20	—
	<b>C8</b>	—	—	40	40	40	—

		RE - RA					
	stages	110	210	310	510	610	810
<b>A1</b>		186	186	244	244	244	295
<b>F0</b>		185	185	222	222	222	280
<b>F2</b>		110 h7	110 h7	150 f7	150 f7	150 f7	200 f7
<b>F3</b>		165	165	195	195	195	250
<b>F4</b>		5	5	13.5	13.5	13.5	10.5
<b>F5</b>		12	12	16	16	16	18
<b>F6</b>		10.5	10.5	12.5	12.5	12.5	15
		M... - 12.9					
<b>F7</b>		M10	M10	M12	M12	M12	M14
<b>F8</b>		45°	45°	36°	36°	36°	30°
<b>FA1</b>		22.5°	22.5°	—	—	—	—
<b>FL</b>	1	6.5	6.5	15	15	15	40
	2	95	107	133	151	151	162.5
	3	138	150	185.5	215.5	209.5	229.5
	4	181	193	228.5	258.5	262	282
<b>FL7</b>	1	224	236	271.5	301.5	305	325
	2	176	188	255	273	273	304.5
	3	219	231	266.5	296.5	331.5	351.5
	4	262	274	309.5	339.5	343	363
<b>FL8</b>	1	250.5	262.5	346	364	364	412.5
	2	293.5	305.5	341	371	422.5	442.5
	3	336.5	348.5	384	414	417.5	437.5
<b>T3</b>	1	113.8	113.8	171.5	171.5	171.5	277
	2	113.8	113.8	113.8	113.8	171.5	171.5
	3	113.8	113.8	113.8	113.8	113.8	113.8
<b>T4</b>	1	184	184	183	183	183	242
	2	184	184	184	184	183	183
	3	184	184	184	184	184	184

**110 - 210  
310 - 510**

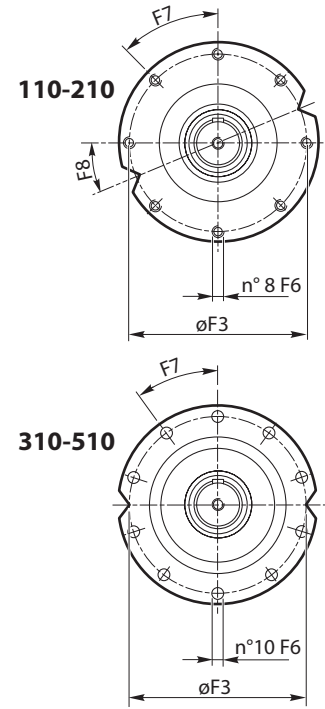
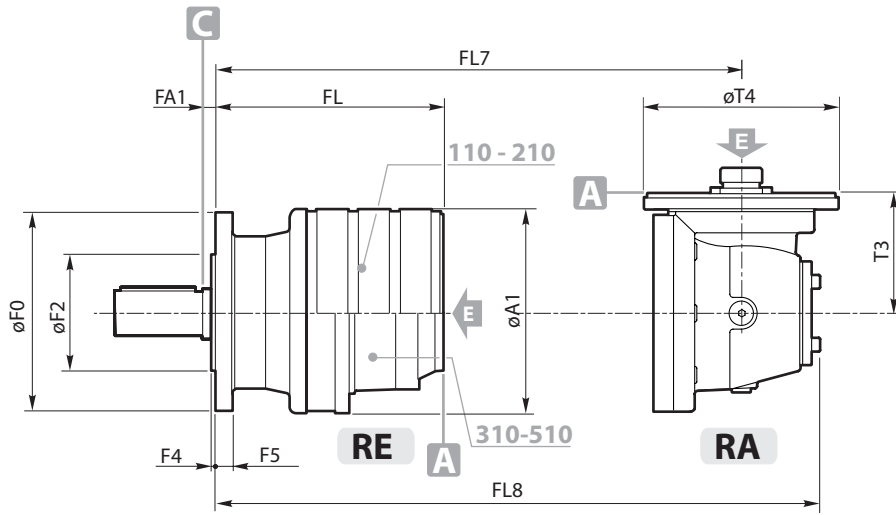

**610**

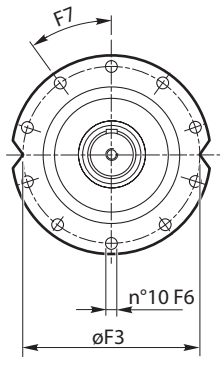
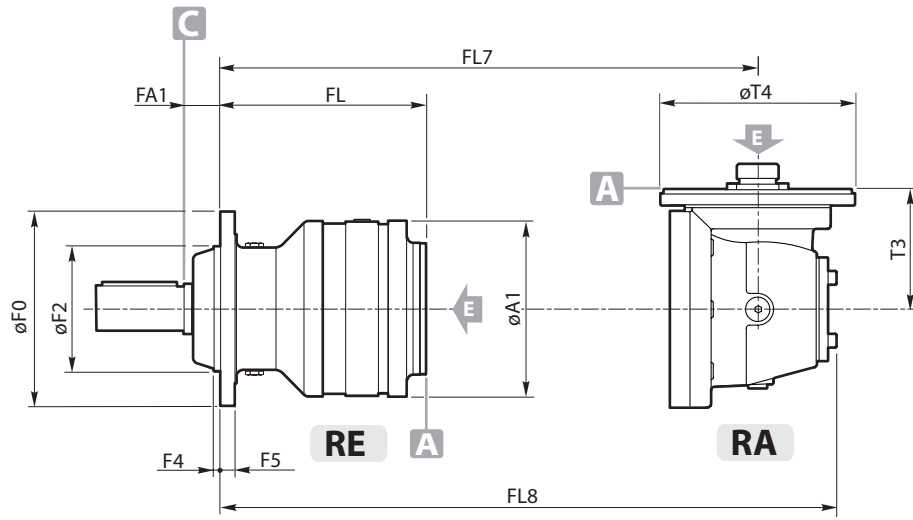

**810**

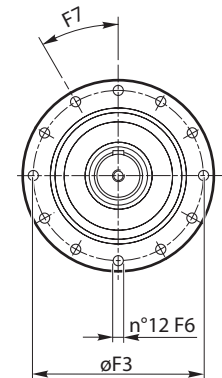
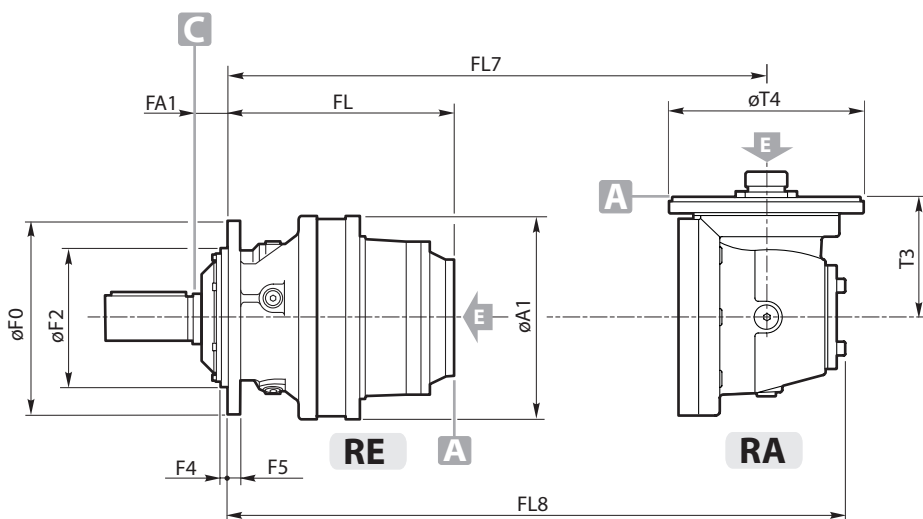

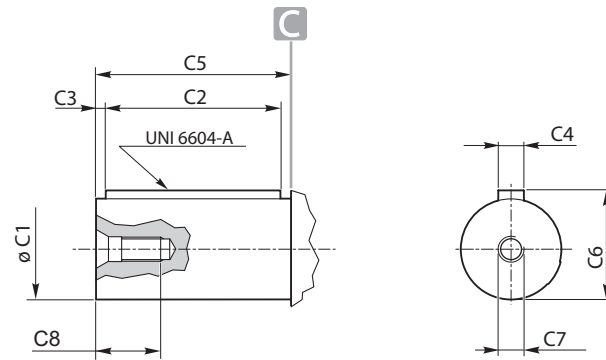

		RE - RA						
		110	210	310	510	610	810	1020
PC	C1	38 h7	38 h7	50 h7	50 h7	50 h7	80 h6	80 h6
	C2	50	50	90	90	90	110	110
	C3	4	4	8	8	8	8	8
	C4	10	10	14	14	14	22	22
	C5	58	58	105	105	105	130	130
	C6	41	41	53.5	53.5	53.5	85	85
	C7	M12	M12	M14	M14	M14	M20	M20
	C8	20	20	30	30	30	45	45

		RE - RA						
		110	210	310	510	610	810	1020
PK	C1	42 h7	42 h7	60 h7	60 h7	60 h7	—	—
	C2	70	70	90	90	90	—	—
	C3	6	6	8	8	8	—	—
	C4	12	12	18	18	18	—	—
	C5	82	82	105	105	105	—	—
	C6	45	45	53.5	53.5	53.5	—	—
	C7	M16	M16	M16	M16	M16	—	—
	C8	30	30	30	30	30	—	—

		RE - RA						
		110	210	310	510	610	810	1020
PK1	C1	/	/	65 h7	65 h7	65 h7	—	—
	C2	/	/	90	90	90	—	—
	C3	/	/	8	8	8	—	—
	C4	/	/	18	18	18	—	—
	C5	/	/	105	105	105	—	—
	C6	/	/	69	69	69	—	—
	C7	/	/	M20	M20	M20	—	—
	C8	/	/	40	40	40	—	—

		RE - RA						
		110	210	310	510	610	810	1020
P1		20	20	28	28	28	35	35
P2		132	132	180	180	180	225	225
P3		20	20	28	28	28	35	35
P4		172	172	236	236	236	295	295
P5		134	134	180	180	180	206	206
P6		190	190	250	250	250	300	300
P7		230	230	310	310	310	370	370
P8		Ø14	Ø14	Ø22	Ø22	Ø22	Ø26	Ø26
		M... - 12.9						
		M12	M12	M20	M20	M20	M24	M24
P9		23	23	26.5	26.5	26.5	36	36
P10		125	125	160	160	160	200	200
P11		218	218	282	282	282	347.5	347.5
P12		—	—	21	21	21	45	45
P13		—	—	21	21	21	45	45
PA1		20	20	29	29	29	35	35
PL	1	101.5	113.5	148	166	166	225	242
	2	144.5	156.5	200.5	230.5	224.5	292	327
	3	187.5	199.5	243.5	273.5	277	344.5	391.5
	4	230.5	242.5	286.5	316.5	320	387.5	434.5
PL7	2	182.5	194.5	297	315	288	367	384
	3	225.5	237.5	281.5	311.5	346.5	414	449
	4	268.5	280.5	324.5	354.5	358	425.5	472.5
PL8	2	257	269	361	379	379	475	492
	3	300	312	356	386	437.5	505	540
	4	343	355	399	429	432.5	500	547
T3	2	113.8	113.8	171.5	171.5	171.5	277	277
	3	113.8	113.8	113.8	113.8	171.5	171.5	171.5
	4	113.8	113.8	113.8	113.8	113.8	113.8	113.8
T4	2	184	184	183	183	183	242	242
	3	184	184	184	184	183	183	183
	4	184	184	184	184	184	184	184

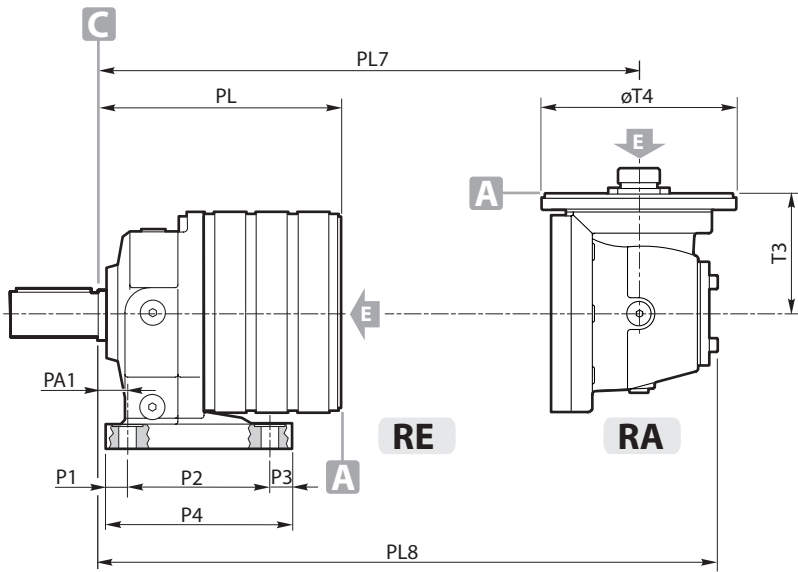

**110 - 210**

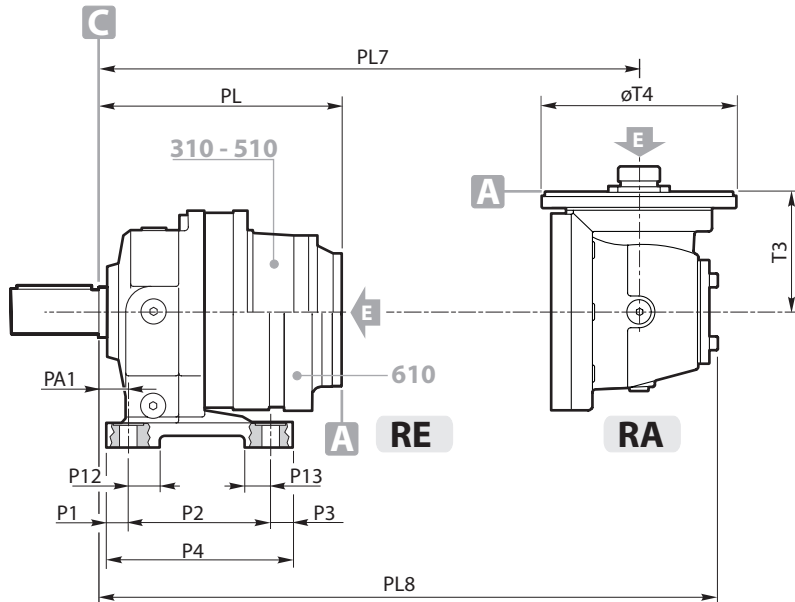
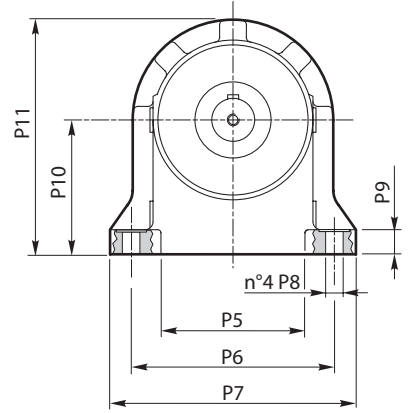

**310 - 510  
610**

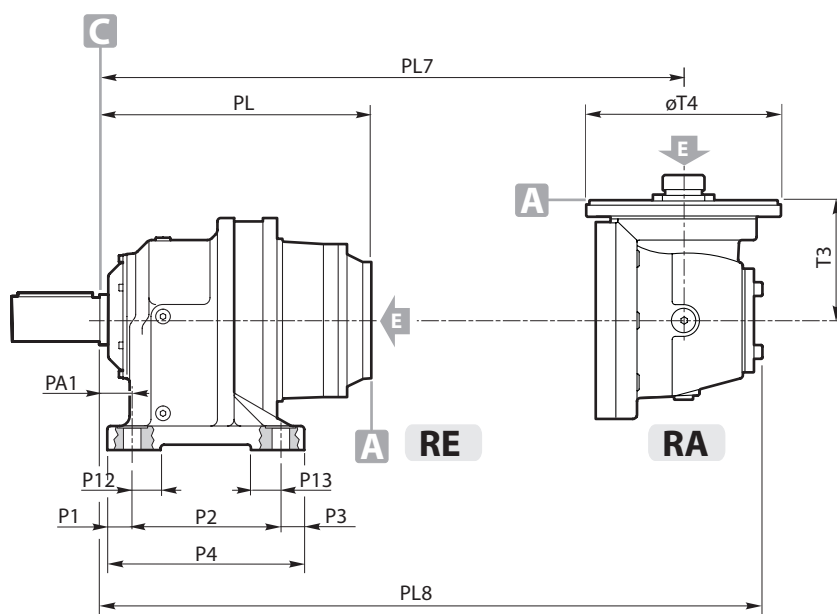
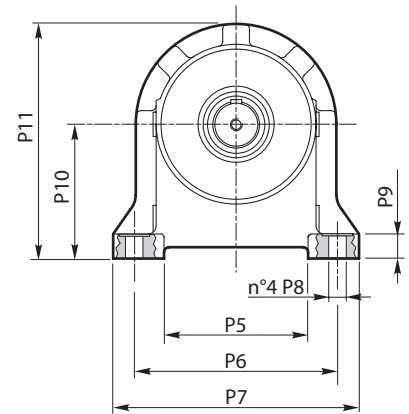

**810 - 1020**

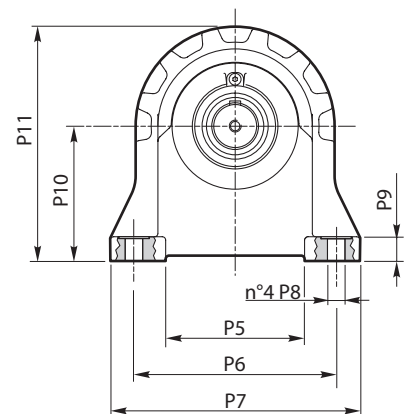

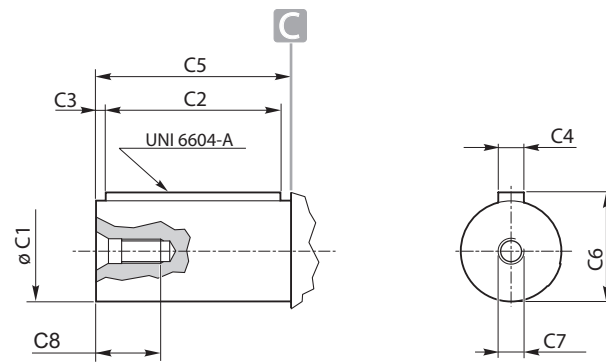

		RE - RA					
		110	210	240	310	510	610
TC T1C TRC TR1C TLC	C1	50 h7	50 h7	50 h7	60 h7	60 h7	60 h7
	C2	90	90	90	90	90	90
	C3	5	5	5	8	8	8
	C4	14	14	14	18	18	18
	C5	100	100	100	105	105	105
	C6	53.5	53.5	53.5	64	64	64
	C7	M12	M12	M12	M16	M16	M16
	C8	30	30	30	30	30	30

		RE - RA					
		110	210	240	310	510	610
TK TLK	C1	/	/	/	65 h7	65 h7	65 h7
	C2	/	/	/	90	90	90
	C3	/	/	/	8	8	8
	C4	/	/	/	18	18	18
	C5	/	/	/	105	105	105
	C6	/	/	/	69	69	69
	C7	/	/	/	M20	M20	M20
	C8	/	/	/	40	40	40

		RE - RA															
		110				210				240		310		510		610	
		T_	T1_	TR_	TR1_	T_	T1_	TR_	TR1_	T_	TR_	T_	TL_	T_	TL_	T_	TL_
A1		186	186	186	186	186	186	186	186	186	186	244	244	244	244	244	244
F0		219	219	219	219	219	219	219	219	219	219	272	272	272	272	272	272
F2		155 h7	150 f7	155 h7	150 f7	155 h7	150 f7	155 h7	150 f7	150 f7	155 f7	175 h8	175 h8	175 h8	175 h8	175 h8	175 h8
F3		194	195	194	195	194	195	194	195	195	194	245	245	245	245	245	245
F4		7	7	10	10	7	7	10	10	7	10	12	9	12	9	12	9
F5		15	15	15	15	15	15	15	15	15	15	20	20	20	20	20	20
F6		Ø11	Ø13	Ø11	Ø13	Ø11	Ø13	Ø11	Ø13	Ø12.5	Ø11	Ø12.5	Ø12.5	Ø12.5	Ø12.5	Ø12.5	Ø12.5
		M. - 12.9															
F7		M10	M12	M10	M12	M10	M12	M10	M12	M12	M10	M12	M12	M12	M12	M12	M12
F7		36°	36°	36°	36°	36°	36°	36°	36°	36°	36°	36°	36°	36°	36°	36°	36°
FA1		13	13	30	30	13	13	30	30	13	30	39	39	39	39	39	39
FL	1	102	102	85	85	114	114	97	97	114	97	157	157	175	175	175	175
	2	145	145	128	128	157	157	140	140	157	140	209.5	209.5	239.5	239.5	233.5	233.5
	3	188	188	171	171	200	200	183	183	200	183	252.5	252.5	282.5	282.5	286	286
	4	231	231	214	214	243	243	226	226	243	226	295.5	295.5	325.5	325.5	329	329
FL7	2	183	183	166	166	195	195	178	178	195	178	279	279	297	297	297	297
	3	226	226	209	209	238	238	221	221	238	221	290.5	290.5	320.5	320.5	355.5	355.5
	4	269	269	252	252	281	281	264	264	281	264	333.5	333.5	363.5	363.5	367	367
FL8	2	257.5	257.5	240.5	240.5	269.5	269.5	252.5	252.5	269.5	252.5	370	370	388	388	388	388
	3	300.5	300.5	283.5	283.5	312.5	312.5	295.5	295.5	312.5	295.5	365	365	395	395	446.5	446.5
	4	343.5	343.5	326.5	326.5	355.5	355.5	338.5	338.5	355.5	338.5	408	408	438	438	441.5	441.5
T3	2	113.8	113.8	113.8	113.8	113.8	113.8	113.8	113.8	113.8	113.8	171.5	171.5	171.5	171.5	171.5	171.5
	3	113.8	113.8	113.8	113.8	113.8	113.8	113.8	113.8	113.8	113.8	113.8	113.8	113.8	113.8	113.8	113.8
	4	113.8	113.8	113.8	113.8	113.8	113.8	113.8	113.8	113.8	113.8	113.8	113.8	113.8	113.8	113.8	113.8
T4	2	184	184	184	184	184	184	184	184	184	184	183	183	183	183	183	183
	3	184	184	184	184	184	184	184	184	184	184	184	184	184	184	183	183
	4	184	184	184	184	184	184	184	184	184	184	184	184	184	184	184	184

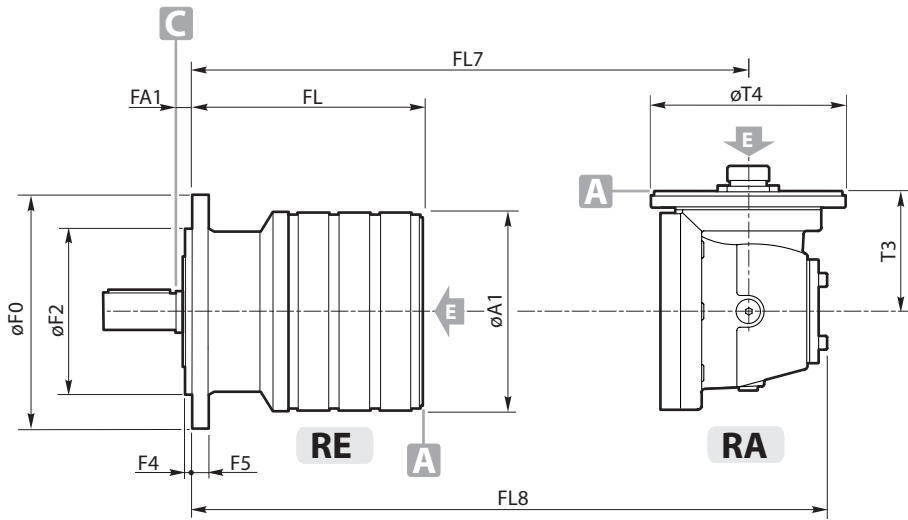

**110 ÷ 240**

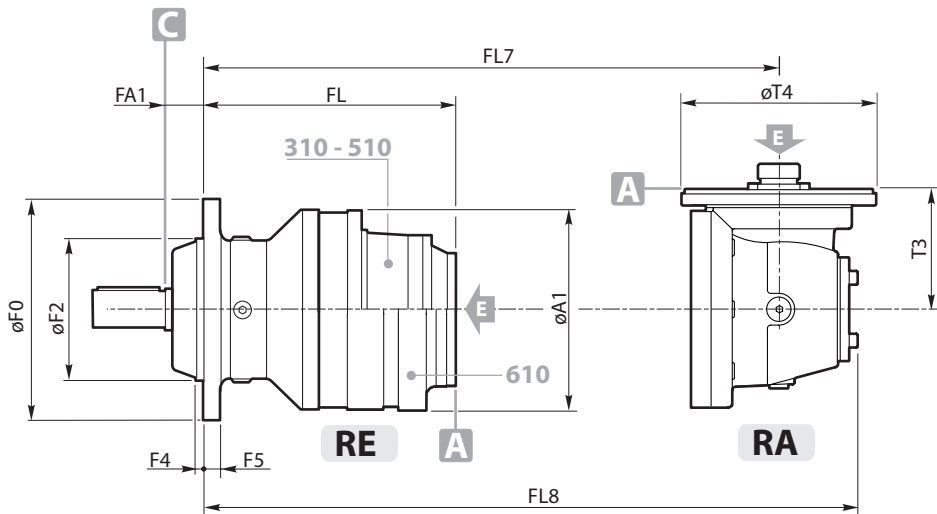
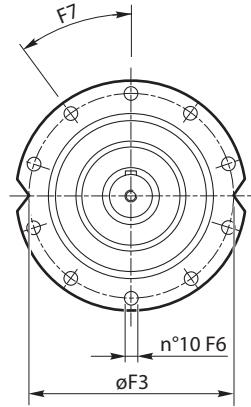

**310 - 510  
610**

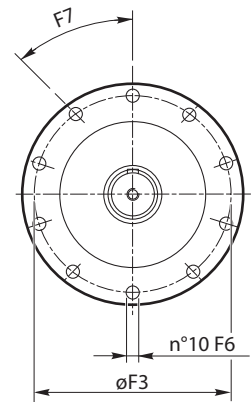

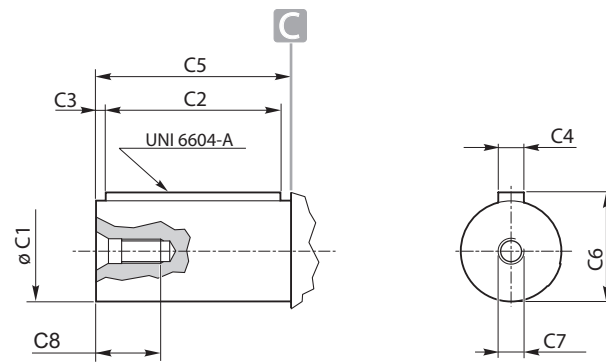
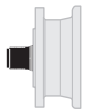

TC	RE - RA				
	810	1020	1520	2000	2000L
C1	80 h6	90 h7	90 h7	90 h7	90 h7
C2	110	160	160	160	160
C3	8	5	5	5	5
C4	22	25	25	25	25
C5	130	170	170	170	170
C6	85	95	95	95	95
C7	M20	M24	M24	M24	M24
C8	45	50	50	50	50

	stages	RE - RA				
		810	1020	1520	2000	2000L
A1		295	295	350	350	350
F0		280	325	325	325	325
F2		200 f7	230 f7	230 f7	230 f7	230 f7
F3		250	295	295	295	295
F4		10.5	15	15	15	15
F5		22	25	28	28	28
F6		Ø15	Ø17	Ø17	Ø17	Ø17
		M... - 12,9				
		M14	M16	M16	M16	M16
F7		30°	36°	36°	36°	36°
FA1		40	36	36	36	36
FL	1	185	237	240	240	240
	2	252	322	333	333	333
	3	304.5	386.5	397.5	391.5	397.5
	4	347.5	429.5	440	444	440
FL7	2	326.5	379	446	446	446
	3	374	444	455	455	455
	4	385.5	467.5	478.5	513.5	478.5
FL8	2	435	487	574	574	574
	3	465	535	546	546	546
	4	460	542	553	604.5	553
T3	2	277	277	310	310	310
	3	171.5	171.5	171.5	171.5	171.5
	4	113.8	113.8	113.8	171.5	113.8
T4	2	242	242	293	293	293
	3	183	183	183	183	183
	4	184	184	184	183	184

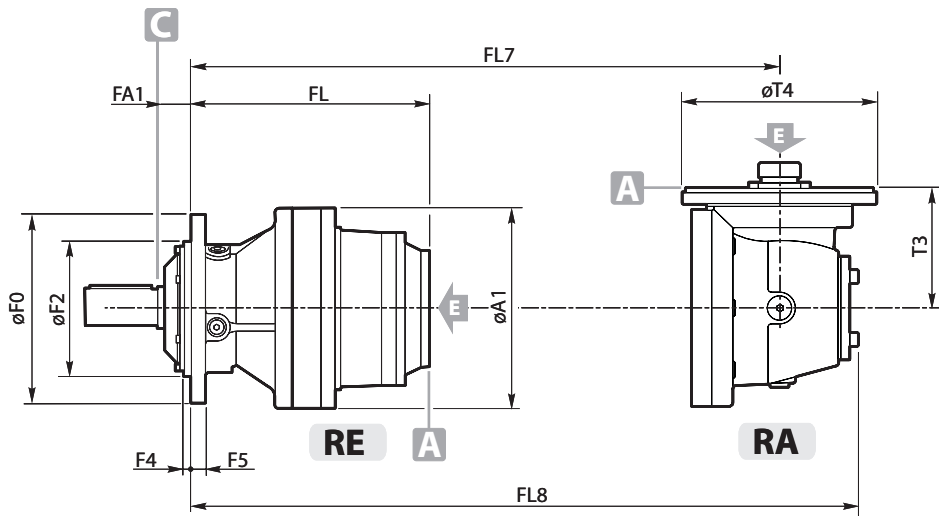

**810**

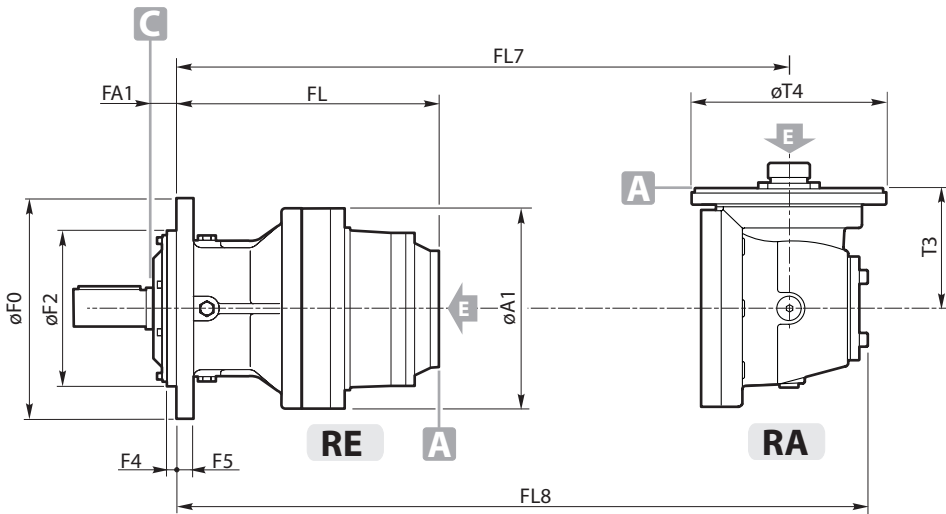
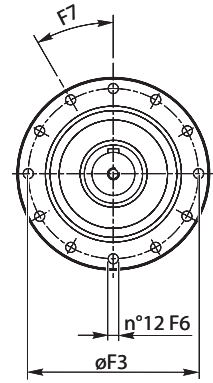

**1020 - 1520  
2000 - 2000L**

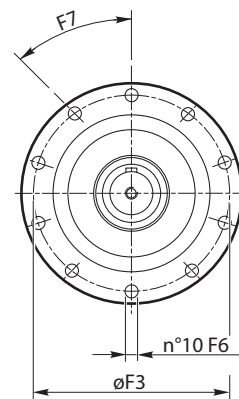

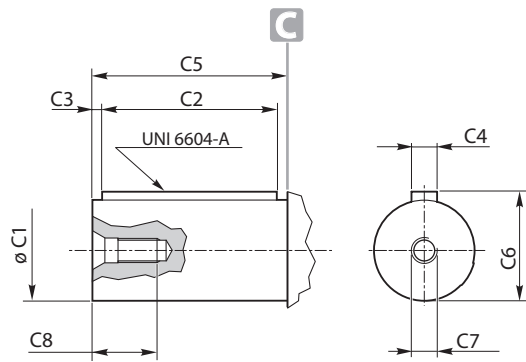

1520 ÷ 3000

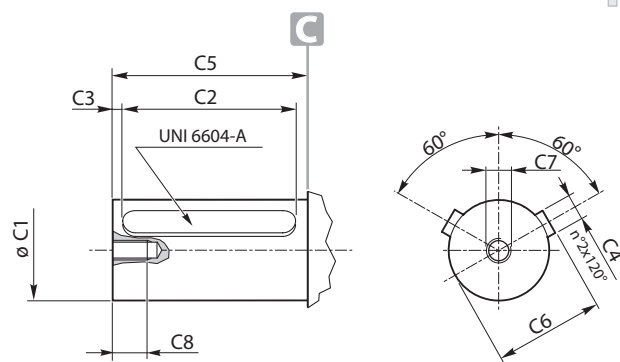

3510 - 4800



		RE - RA						
		1520	2000	2000L	2520	3000	3510	4800
HC	C1	90 h6	90 h6	90 h6	110 h6	110 h6	120 h7	120 h7
	C2	160	160	160	200	200	200	200
	C3	5	5	5	5	5	5	5
	C4	25	25	25	28	28	32	32
	C5	170	170	170	210	210	210	210
	C6	95	95	95	116	116	127	127
	C7	M24	M24	M24	M24	M24	M24	M24
	C8	50	50	50	50	50	50	50

		RE - RA						
		stages	1520	2000	2000L	2520	3000	3510
A1		350	350	350	409	409	452	452
FA1		169	169	169	180	180	109	109
F2		278 f7	278 f7	278 f7	340 f7	340 f7	390 f8	390 f8
F3		314	314	314	370	370	424	424
F4		10	10	10	17	17	15	15
F5		133	133	133	131	131	120	120
F6		Ø16.5	Ø16.5	Ø16.5	Ø17	Ø17	Ø17	Ø17
F6A		M16	M16	M16	M16	M16	M16	M16
F7		Ø12	Ø12	Ø12	Ø16	Ø16	/	/
F7A		15°	15°	15°	12°	12°	20°	20°
F8		30°	30°	30°	30°	30°	/	/
F8		15°	15°	15°	24°	24°	10°	10°
	1	107	107	107	98	98	85	85
	2	200	200	200	209	226	277	326
	3	264.5	258.5	264.5	276	311	362	419
FL	4	307.5	311	307.5	328.5	375.5	426.5	483.5
	2	313	313	313	292	292	339	339
	3	322	322	322	351	368	419	532
FL7	4	345.5	380.5	345.5	398	433	484	541
	2	441	441	441	420	420	529	529
FL8	3	413	413	413	459	476	527	660
	4	420	472	420	489	524	575	632
	G2	225 f7	225 f7	225 f7	245 f7	245 f7	/	/
G4	104.5	104.5	104.5	142	142	/	/	
G5	27.5	27.5	27.5	29	29	/	/	
H	15	15	15	29	29	/	/	
T3	2	310	310	310	310	310	432	432
	3	171	171	171	227	227	227	310
	4	113.8	171	113.8	171	171	171	171
T4	2	293	293	293	293	293	295	295
	3	183	183	183	242	242	242	293
	4	184	183	184	183	183	183	183

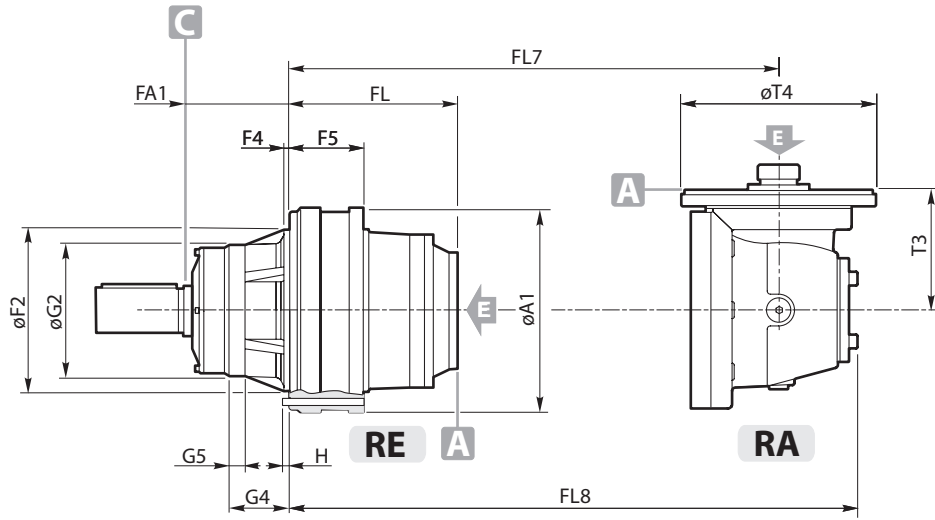

**1520 - 2000  
2000L**

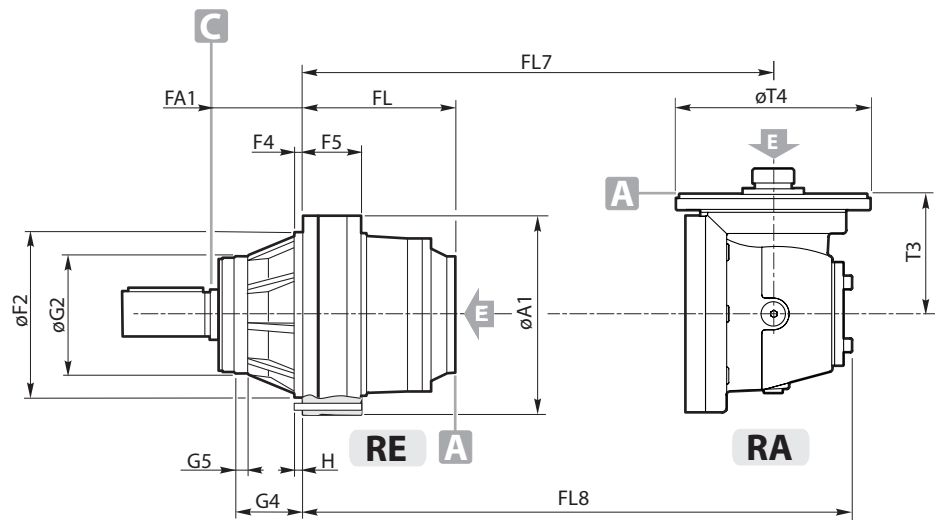
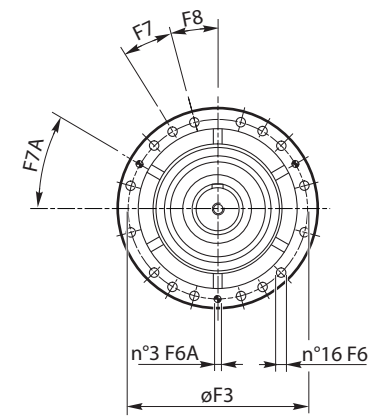

**2520 - 3000**

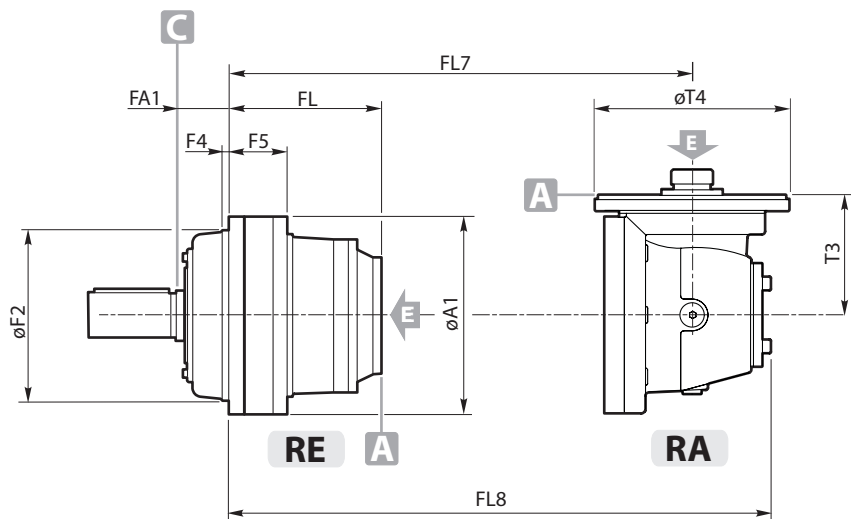
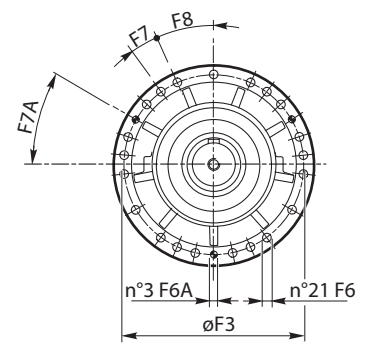

**3510 - 4800**

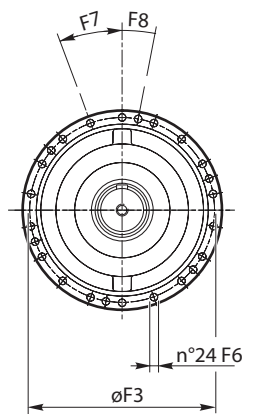

# HC/H6C

RE/RA 6000 - 8000 GB/GBA 12010 - 16000

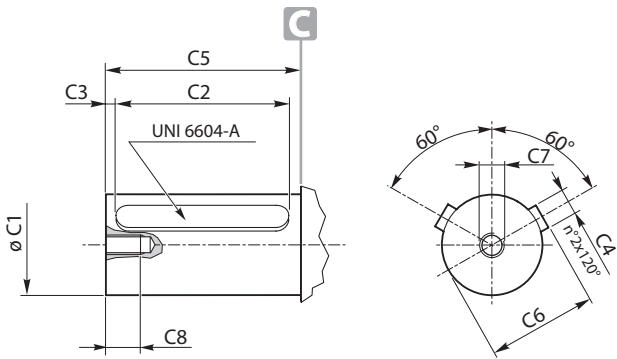
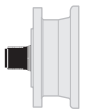

6000 - 8000

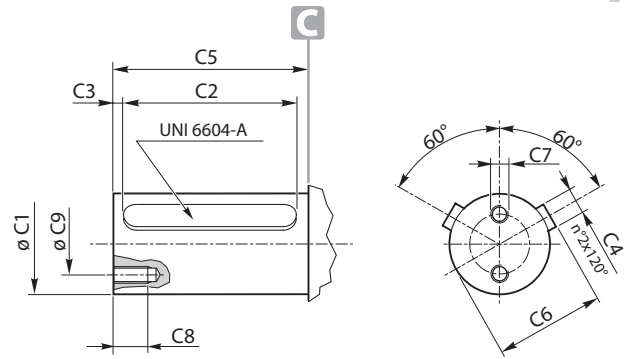

12010 - 16000



		RE - RA		GB - GBA		
		6000		8000	12010	16000
		HC	H6C	HC	HC	HC
HC H6C	C1	140 h6	160 h7	160 h7	180 h7	180 h7
	C2	200	210	210	220	220
	C3	10	10	10	10	10
	C4	36	40	40	45	45
	C5	220	230	230	240	240
	C6	148	169	169	190	190
	C7	M24	M24	M24	M16(2)	M16(2)
	C8	50	50	50	35	35
	C9	—	—	—	110	110

	stages	RE - RA			GB - GBA	
		6000		8000	12010	16000
		HC	H6C	HC	HC	HC
A1		490	490	490	610	610
F2		410 f7	410 h8	410 h8	515 h8	515 h8
F3		445	445	445	560	560
F4		15	15	15	20	20
F5		187	178.5	181.5	230	230
F6		Ø19	Ø19	Ø19	Ø25	Ø25
		M. - 12.9		M. - 10.9		
F7		M18	M18	M18	M24	M24
F7		7°30'	7°30'	7°30'	15°	15°
F8		15°	15°	15°	7°30'	7°30'
F9		7°30'	7°30'	7°30'	7°30'	7°30'
FA1		226	126	126	145	145
FL	1	145	136.5	136.5	160.5	160.5
	2	313.5	305	390.5	410	427
	3	406.5	398	518.5	538	668
	4	465	456.5	603.5	623	761
	5	—	—	668	687.5	825.5
FL7	2	399	390.5	390.5	—	—
	3	519.5	511	584.5	604	681
	4	528.5	520	660.5	680	874
	5	—	—	—	745	883
FL8	2	589	580.5	580.5	—	—
	3	647.5	639	712.5	732	871
	4	619.5	611	768.5	788	1002
	5	—	—	—	836	974
G2		260 f7	—	—	—	—
G4		181	—	—	—	—
G5		33	—	—	—	—
T3	2	432	432	432	—	—
	3	310	310	310	310	432
	4	171	171	227	227	310
	5	—	—	—	171	171
T4	2	295	295	295	—	—
	3	293	293	293	293	295
	4	183	183	242	242	293
	5	—	—	—	183	183

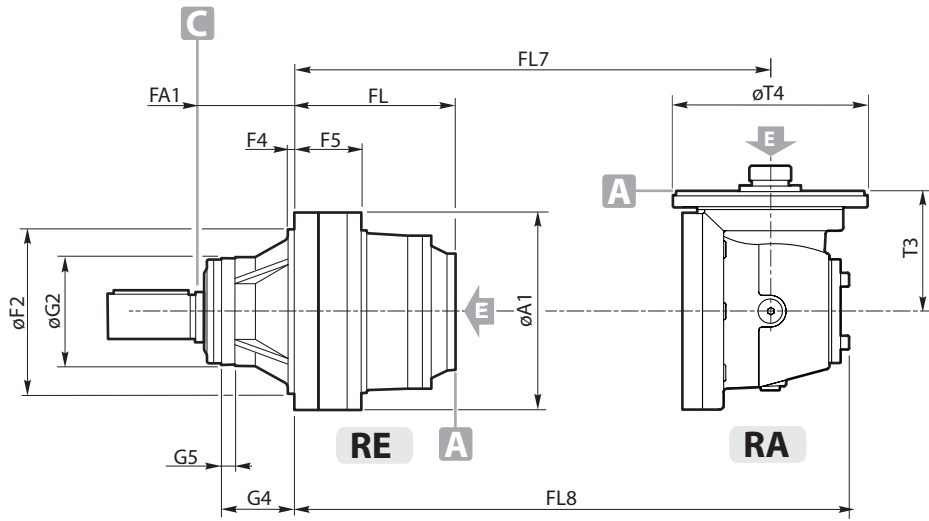

**HC 6000**

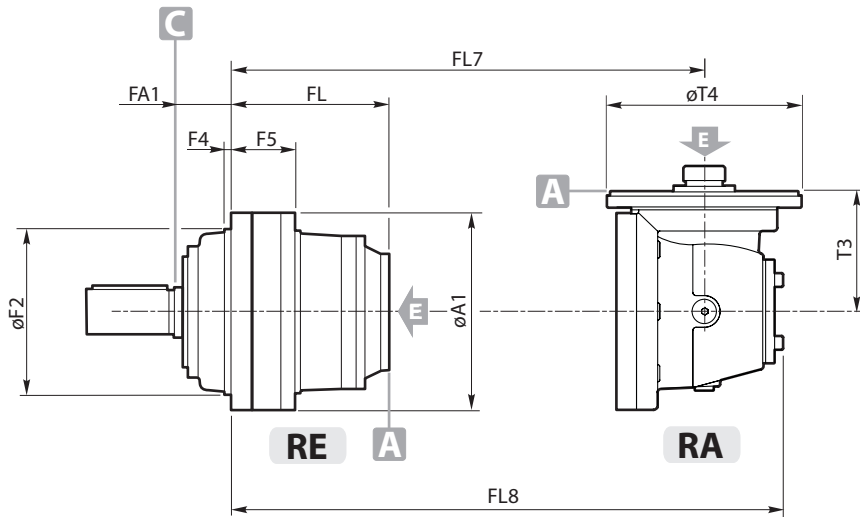
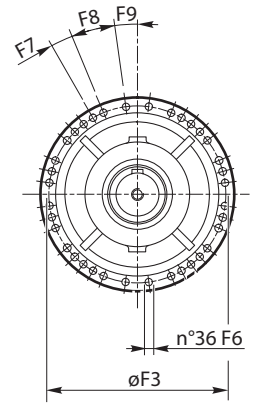

**H6C 6000**

**HC 8000**

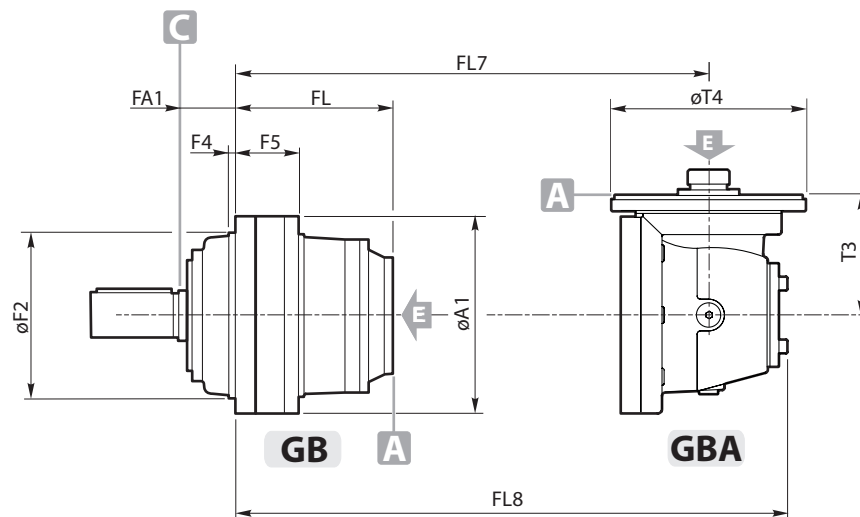
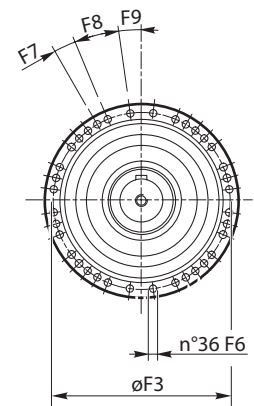

**HC 12010 - 16000**

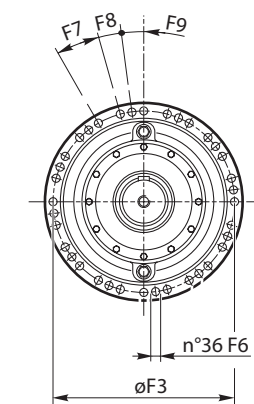

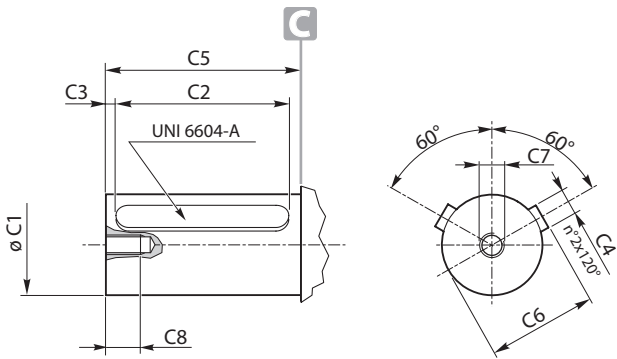
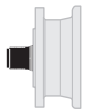

**6000L - 8000L**

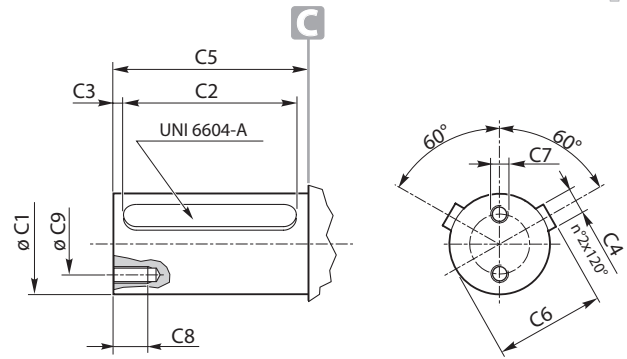

**12010L - 16000L**



		RE - RA		GB - GBA		
		6000L		8000L	12010L	16000L
		HC	H6C	HC	HC	HC
<b>HC H6C</b>	C1	140 h6	160 h7	160 h7	180 h7	180 h7
	C2	200	210	210	220	220
	C3	10	10	10	10	10
	C4	36	40	40	45	45
	C5	220	230	230	240	240
	C6	148	169	169	190	190
	C7	M24	M24	M24	M16(2)	M16(2)
	C8	50	50	50	35	35
	C9	—	—	—	110	110

	stages	RE - RA			GB - GBA	
		6000L		8000L	12010L	16000L
		HS	H6S	HS	HS	HS
A1		490	490	490	610	610
F2		410 f7	410 h8	410 h8	515 h8	515 h8
F3		445	445	445	560	560
F4		15	15	15	20	20
F5		187	178.5	181.5	230	230
F6		Ø19	Ø19	Ø19	Ø25	Ø25
		M18 M18 M18		M24 M24		
F7		7°30'	7°30'	7°30'	15°	15°
F8		15°	15°	15°	7°30'	7°30'
F9		7°30'	7°30'	7°30'	7°30'	7°30'
FA1		226	126	126	145	145
FL	1	145	136.5	136.5	160.5	160.5
	2	313.5	305	390.5	410	427
	3	406.5	398	501.5	521	619
	4	471	462.5	568.5	588	704
	5	—	—	621	640.5	768.5
FL7	2	399	390.5	390.5	—	—
	3	519.5	511	584.5	604	681
	4	528.5	520	643.5	663	761
	5	—	—	—	710	826
FL8	2	589	580.5	580.5	—	—
	3	647.5	639	712.5	732	871
	4	619.5	611	751.5	771	869
	5	—	—	—	801	917
G2		260 f7	—	—	—	—
G4		181	—	—	—	—
G5		33	—	—	—	—
T3	2	432	432	432	—	—
	3	310	310	310	310	432
	4	171	171	227	227	227
	5	—	—	—	171	171
T4	2	295	295	295	—	—
	3	293	293	293	293	295
	4	183	183	242	242	242
	5	—	—	—	183	183

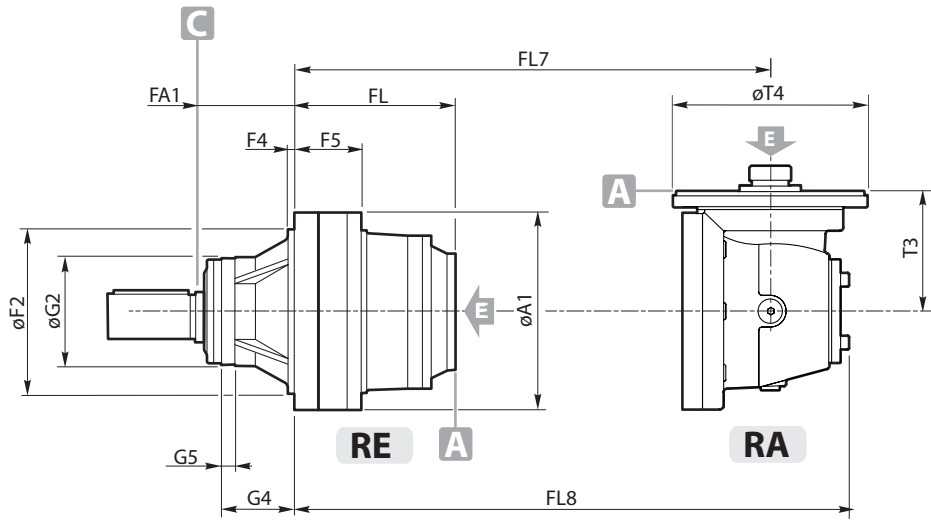

**HC 6000L**

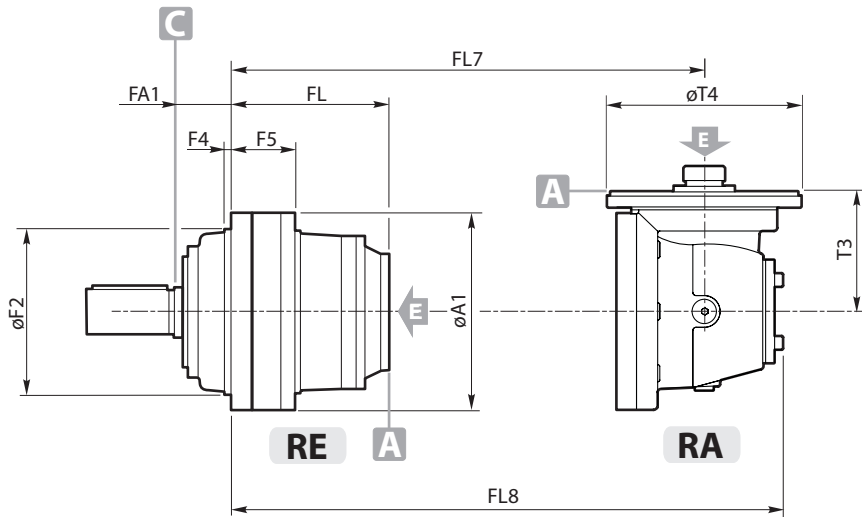
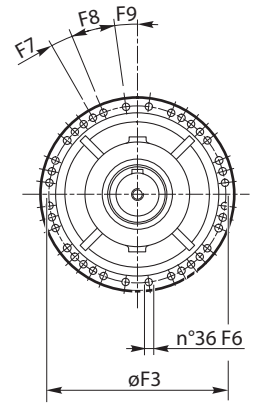

**H6C 6000L**

**HC 8000L**

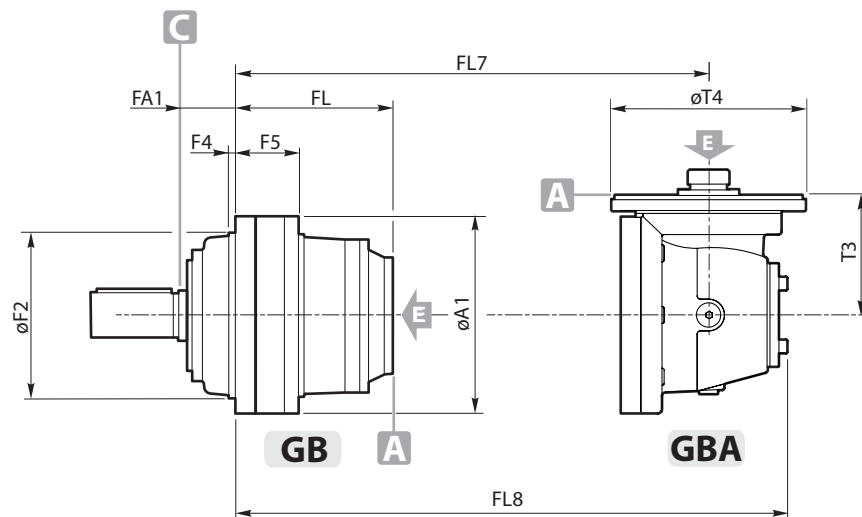
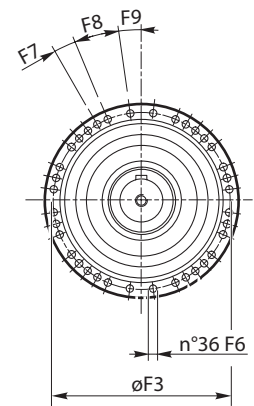

**HC 12010L-16000L**

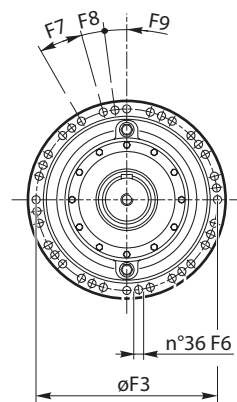

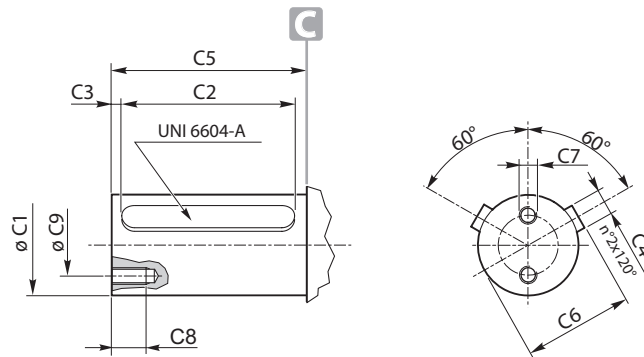
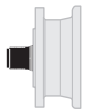

TC	GB - GBA				
	21000	26000	31000	40000	45000
C1	230 h7	230 h7	290 h7	290 h7	290 h7
C2	280	280	400	400	400
C3	10	10	12.5	12.5	12.5
C4	50	50	63	63	63
C5	300	300	425	425	425
C6	241	241	302	302	302
C7	M24(2)	M24(2)	M24(2)	M24(2)	M24(2)
C8	50	50	50	50	50
C9	150	150	200	200	200

	stages	GB - GBA				
		21000	26000	31000	40000	45000
A1		710	710	870	870	870
F2		600 h8	600 h8	760 h8	760 h8	760 h8
F3		660	660	810	810	810
F4		23.5	23.5	35	35	35
F5		196	216	250	290	290
F6		Ø28	Ø28	Ø32	Ø32	Ø32
		M. - 10.9				
F7		M27	M27	M30	M30	M30
F7		10°	10°	10°	10°	10°
FA1		180	180	225	225	225
FL	1	138	158	180	220	220
	2	443	463	588.5	628.5	628.5
	3	611.5	717	838	878	895
	4	704.5	845	966	1006	1136
	5	763	930	1051	1091	1229
FL7	3	697	717	—	—	—
	4	817.5	911	1032	1072	1149
	5	826.5	987	1108	1148	1342
FL8	3	887	907	—	—	—
	4	945.5	1039	1160	1200	1339
	5	917.5	1095	1216	1256	1470
T3	3	432	432	—	—	—
	4	310	310	310	310	432
	5	171	227	227	227	310
T4	3	295	295	—	—	—
	4	293	293	293	293	295
	5	183	242	242	242	293

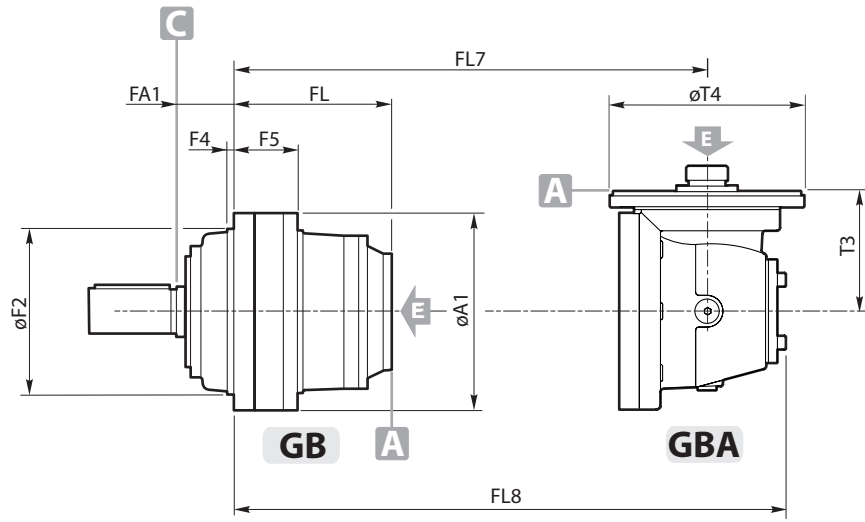

**21000 ÷ 45000**

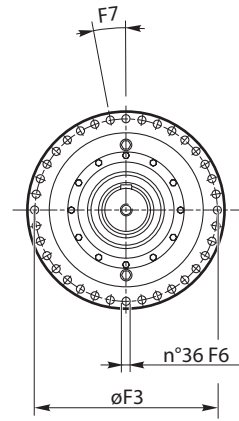

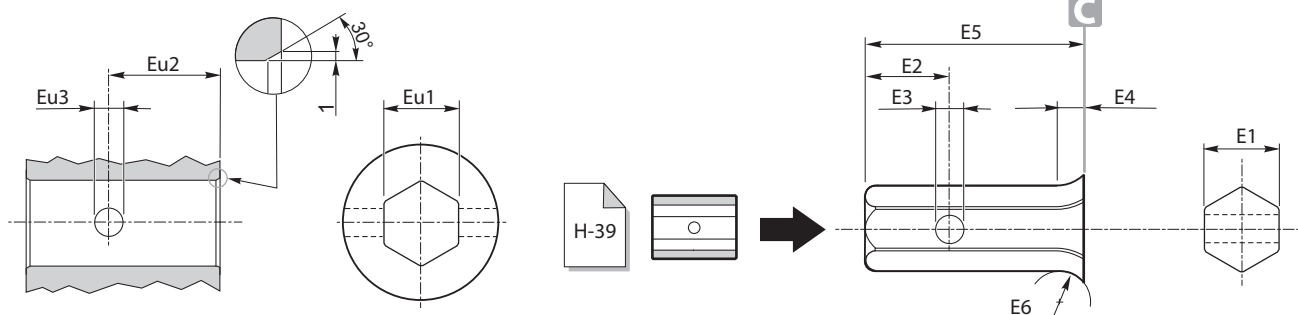

	RE - RA				
	110	210	310	510	610
<b>E1</b>	50	50	50	50	50
<b>E2</b>	54	54	54	54	54
<b>E3</b>	Ø 18	Ø 18	Ø 18	Ø 18	Ø 18
<b>E4</b>	6.5	6.5	13	13	13
<b>E5</b>	121	121	132	132	132
<b>E6</b>	r 24	r 24	r 24	r 24	r 24
<b>Eu1</b>	50	50	50	50	50
<b>Eu2</b>	54	54	60	60	60
<b>Eu3</b>	Ø 18	Ø 18	Ø 18	Ø 18	Ø 18

	stages	RE - RA				
		110	210	310	510	610
<b>A1</b>		186	186	244	244	244
<b>F0</b>		185	185	222	222	222
<b>F2</b>		110 h7	110 h7	150 f7	150 f7	150 f7
<b>F3</b>		165	165	195	195	195
<b>F4</b>		3	3	13.5	13.5	13.5
<b>F5</b>		14	14	16	16	16
<b>F6</b>		10.5	10.5	12.5	12.5	12.5
		M... - 12,9				
		M10	M10	M12	M12	M12
<b>F7</b>		45°	45°	36°	36°	36°
<b>F8</b>		22.5°	22.5°	—	—	—
<b>FA1</b>		7	7	22	22	22
<b>FL</b>	1	97	109	134	152	152
	2	140	152	186.5	216.5	210.5
	3	183	195	229.5	259.5	263
	4	226	238	272.5	302.5	306
<b>FL7</b>	2	178	190	256	274	274
	3	221	233	267.5	297.5	332.5
<b>FL8</b>	2	252.5	264.5	347	365	365
	3	295.5	307.5	342	372	423.5
	4	338.5	350.5	385	415	418.5
<b>T3</b>	2	113.8	113.8	171.5	171.5	171.5
	3	113.8	113.8	113.8	113.8	171.5
	4	113.8	113.8	113.8	113.8	113.8
<b>T4</b>	2	184	184	183	183	183
	3	184	184	184	184	183
	4	184	184	184	184	184

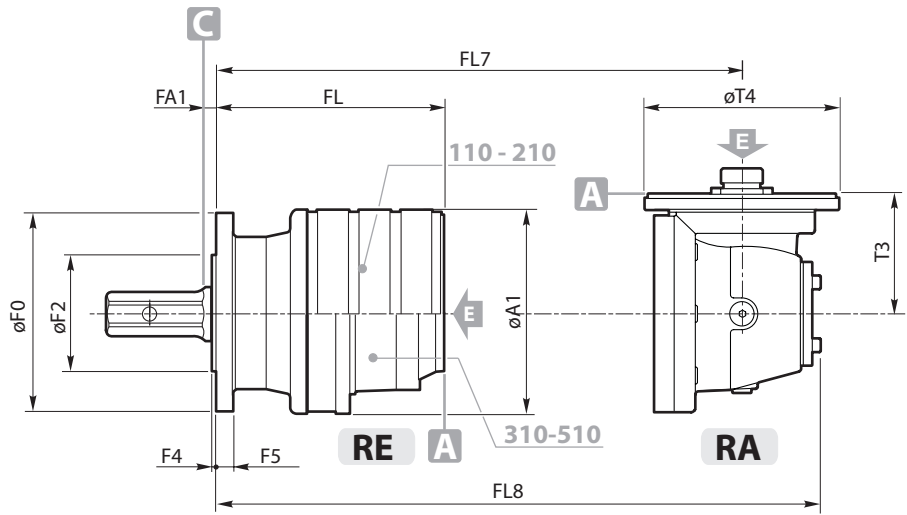

**110 - 210  
310 - 510**

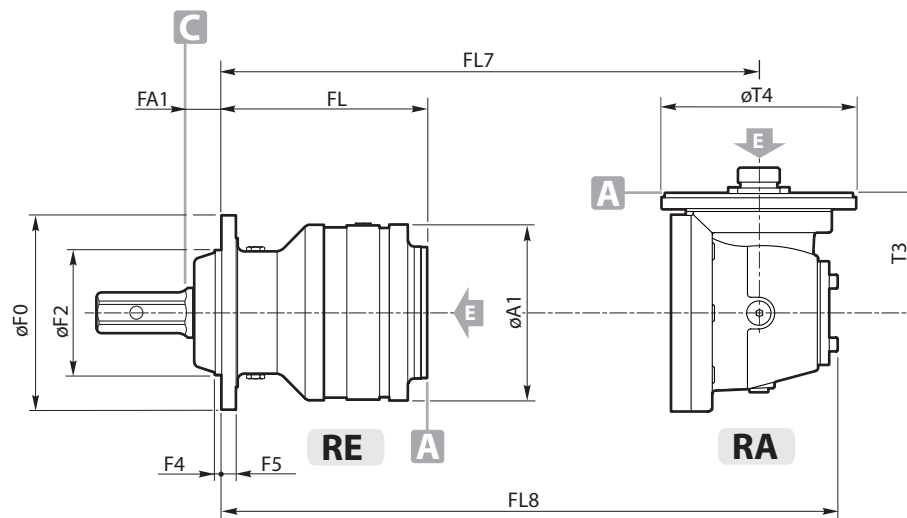
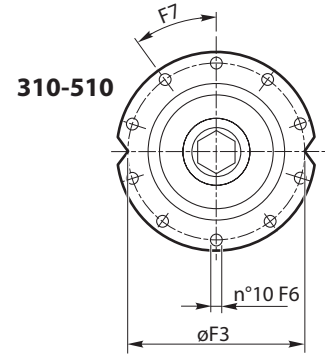
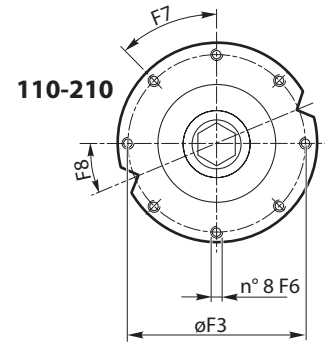

**610**

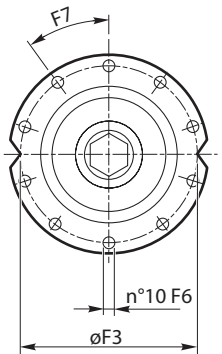

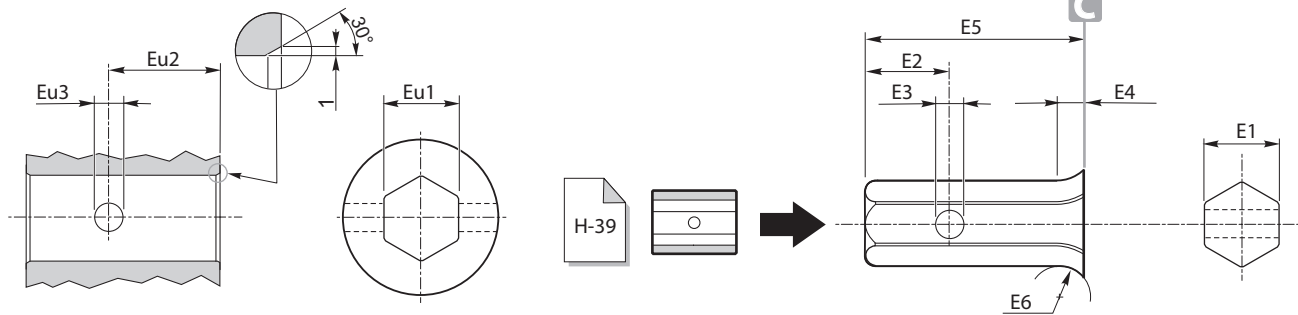

		RE - RA					
		110	210	240	310	510	610
<b>TE</b>	<b>E1</b>	50	50	50	70	70	70
	<b>E2</b>	54	54	54	65	65	65
	<b>E3</b>	Ø 18	Ø 18	Ø 18	Ø 22	Ø 22	Ø 22
	<b>E4</b>	9	9	15	15	15	15
	<b>E5</b>	121	121	119.5	138	138	138
	<b>E6</b>	r 15	r 15	r 24	r 30	r 30	r 30
<b>T1E</b>	<b>Eu1</b>	50	50	50	70	70	70
	<b>Eu2</b>	54	54	54	50	50	50
	<b>Eu3</b>	Ø 18	Ø 18	Ø 18	Ø 22	Ø 22	Ø 22



		RE - RA																	
	stages	110				210				240		310		510		610			
		TE	T1E	TRE	TR1E	TE	T1E	TRE	TR1E	TE	TRE	TE	TLE	TE	TLE	TE	TLE	TE	TLE
<b>A1</b>		186	186	186	186	186	186	186	186	186	244	244	244	244	244	244	244	244	244
<b>F0</b>		219	219	219	219	219	219	219	219	219	272	272	272	272	272	272	272	272	272
<b>F2</b>		155 h7	150 f7	155 h7	150 f7	155 h7	150 f7	155 h7	150 f7	150 f7	155 f7	175 h8	175 h8	175 h8	175 h8	175 h8	175 h8	175 h8	175 h8
<b>F3</b>		194	195	194	195	194	195	194	195	195	194	245	245	245	245	245	245	245	245
<b>F4</b>		7	7	10	10	7	7	10	10	7	10	12	9	12	9	12	9	12	9
<b>F5</b>		15	15	15	15	15	15	15	15	15	15	20	20	20	20	20	20	20	20
<b>F6</b>		Ø11	Ø13	Ø11	Ø13	Ø11	Ø13	Ø11	Ø13	Ø12.5	Ø11	Ø12.5	Ø12.5	Ø12.5	Ø12.5	Ø12.5	Ø12.5	Ø12.5	Ø12.5
		M. - 12,9																	
		M10	M12	M10	M12	M10	M12	M10	M12	M12	M10	M12	M12	M12	M12	M12	M12	M12	M12
<b>F7</b>		36°	36°	36°	36°	36°	36°	36°	36°	36°	36°	36°	36°	36°	36°	36°	36°	36°	36°
<b>FA1</b>		17	17	34	34	17	17	34	34	17.5	34.5	47.5	47.5	47.5	47.5	47.5	47.5	47.5	47.5
<b>FL</b>	1	102	102	85	85	114	114	97	97	114	97	157	157	175	175	175	175	175	175
	2	145	145	128	128	157	157	140	140	157	140	209.5	209.5	239.5	239.5	233.5	233.5	233.5	233.5
	3	188	188	171	171	200	200	183	183	200	183	252.5	252.5	282.5	282.5	286	286	286	286
	4	231	231	214	214	243	243	226	226	243	226	295.5	295.5	325.5	325.5	329	329	329	329
<b>FL7</b>	2	183	183	166	166	195	195	178	178	195	178	279	279	297	297	297	297	297	297
	3	226	226	209	209	238	238	221	221	238	221	290.5	290.5	320.5	320.5	355.5	355.5	355.5	355.5
	4	269	269	252	252	281	281	264	264	281	264	333.5	333.5	363.5	363.5	367	367	367	367
<b>FL8</b>	2	257.5	257.5	240.5	240.5	269.5	269.5	252.5	252.5	269.5	252.5	370	370	388	388	388	388	388	388
	3	300.5	300.5	283.5	283.5	312.5	312.5	295.5	295.5	312.5	295.5	365	365	395	395	446.5	446.5	446.5	446.5
	4	343.5	343.5	326.5	326.5	355.5	355.5	338.5	338.5	355.5	338.5	408	408	438	438	441.5	441.5	441.5	441.5
<b>T3</b>	2	113.8	113.8	113.8	113.8	113.8	113.8	113.8	113.8	113.8	113.8	171.5	171.5	171.5	171.5	171.5	171.5	171.5	171.5
	3	113.8	113.8	113.8	113.8	113.8	113.8	113.8	113.8	113.8	113.8	113.8	113.8	113.8	113.8	113.8	113.8	113.8	113.8
	4	113.8	113.8	113.8	113.8	113.8	113.8	113.8	113.8	113.8	113.8	113.8	113.8	113.8	113.8	113.8	113.8	113.8	113.8
<b>T4</b>	2	184	184	184	184	184	184	184	184	184	184	183	183	183	183	183	183	183	183
	3	184	184	184	184	184	184	184	184	184	184	184	184	184	184	184	184	183	183
	4	184	184	184	184	184	184	184	184	184	184	184	184	184	184	184	184	184	184

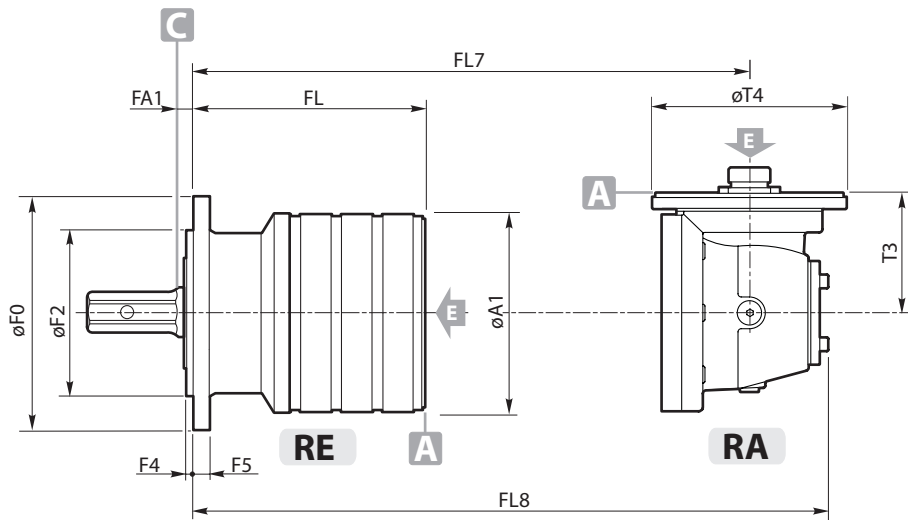

**110 ÷ 240**

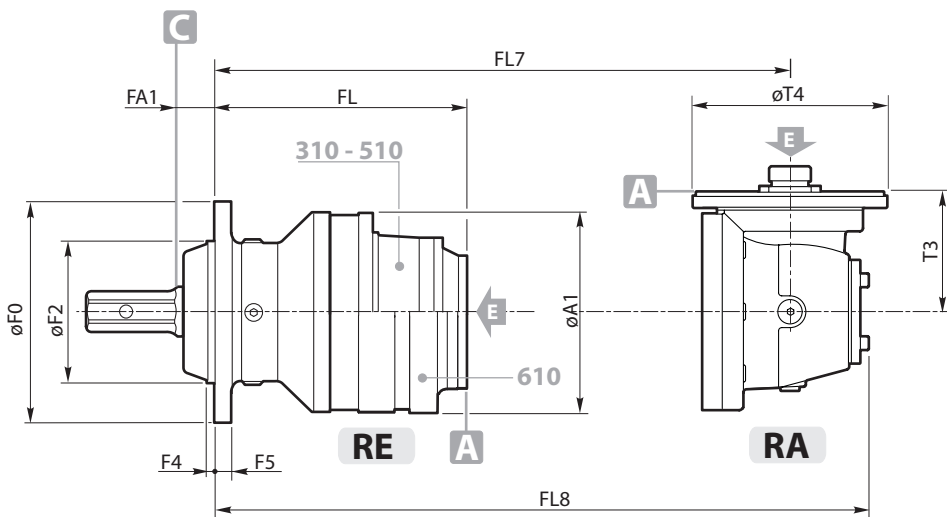
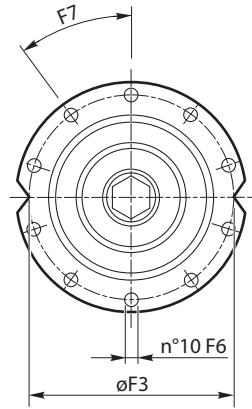

**310 - 510  
610**

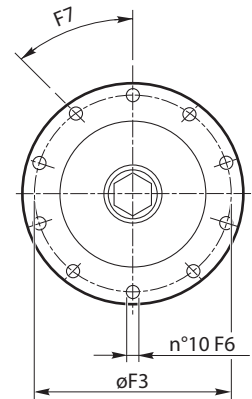

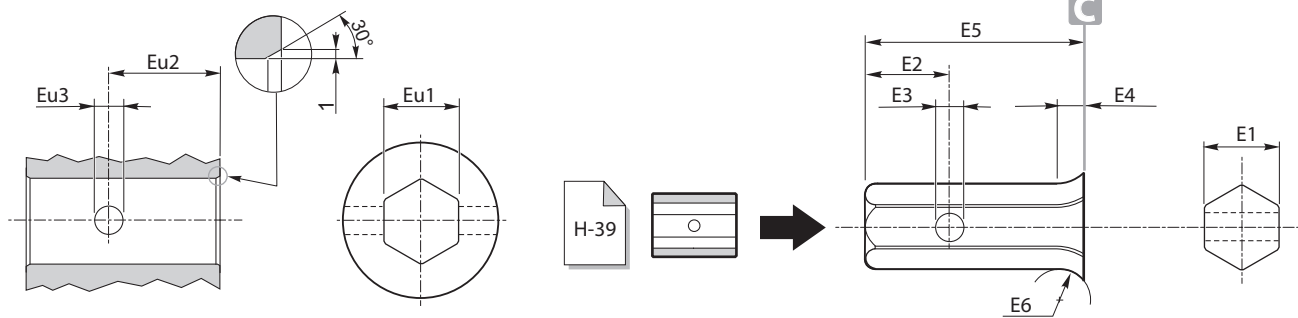

	RE - RA				
	810	1020	1520	2000	2000L
<b>E1</b>	70	70	70	70	70
<b>E2</b>	40	65	65	65	65
<b>E3</b>	Ø 22	Ø 22	Ø 22	Ø 22	Ø 22
<b>E4</b>	3	25	25	25	25
<b>E5</b>	141	142.5	142.5	142.5	142.5
<b>E6</b>	r 30	r 30	r 30	r 30	r 30
<b>Eu1</b>	70	70	70	70	70
<b>Eu2</b>	95	50	50	50	50
<b>Eu3</b>	Ø 22	Ø 22	Ø 22	Ø 22	Ø 22

	stages	RE - RA				
		810	1020	1520	2000	2000L
<b>A1</b>		295	295	350	350	350
<b>F0</b>		280	325	325	325	325
<b>F2</b>		200 f7	230 f7	230 f7	230 f7	230 f7
<b>F3</b>		250	295	295	295	295
<b>F4</b>		10.5	15	15	15	15
<b>F5</b>		22	25	28	28	28
<b>F6</b>		Ø15	Ø17	Ø17	Ø17	Ø17
		M14	M16	M16	M16	M16
<b>F7</b>		30°	36°	36°	36°	36°
<b>FA1</b>		41	43.5	43.5	43.5	43.5
<b>FL</b>	1	185	237	240	240	240
	2	252	322	333	333	333
	3	304.5	386.5	397.5	391.5	397.5
	4	347.5	429.5	440	444	440
<b>FL7</b>	2	326.5	379	446	446	446
	3	374	444	455	455	455
	4	385.5	467.5	478.5	513.5	478.5
<b>FL8</b>	2	435	487	574	574	574
	3	465	535	546	546	546
	4	460	542	553	604.5	553
<b>T3</b>	2	277	277	310	310	310
	3	171.5	171.5	171.5	171.5	171.5
<b>T4</b>	4	113.8	113.8	113.8	171.5	113.8
	2	242	242	293	293	293
	3	183	183	183	183	183
	4	184	184	184	183	184

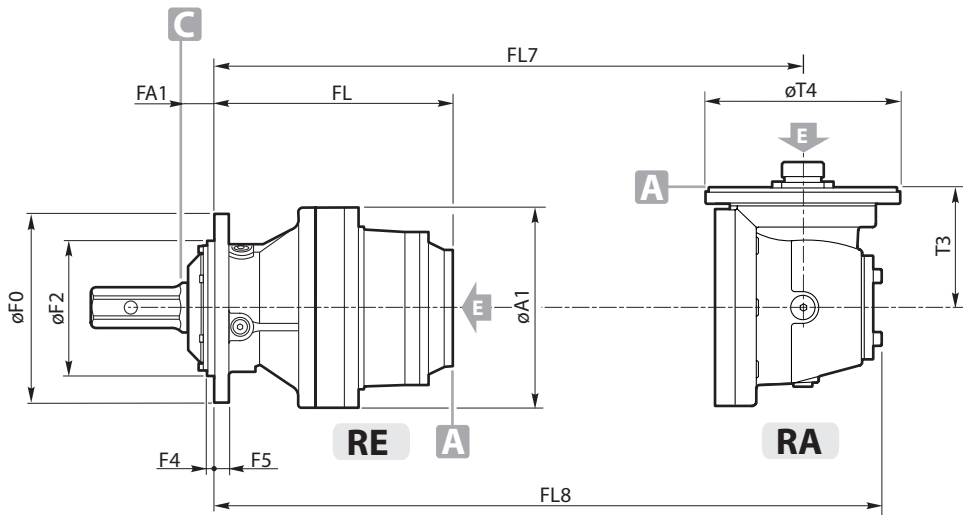

**810**

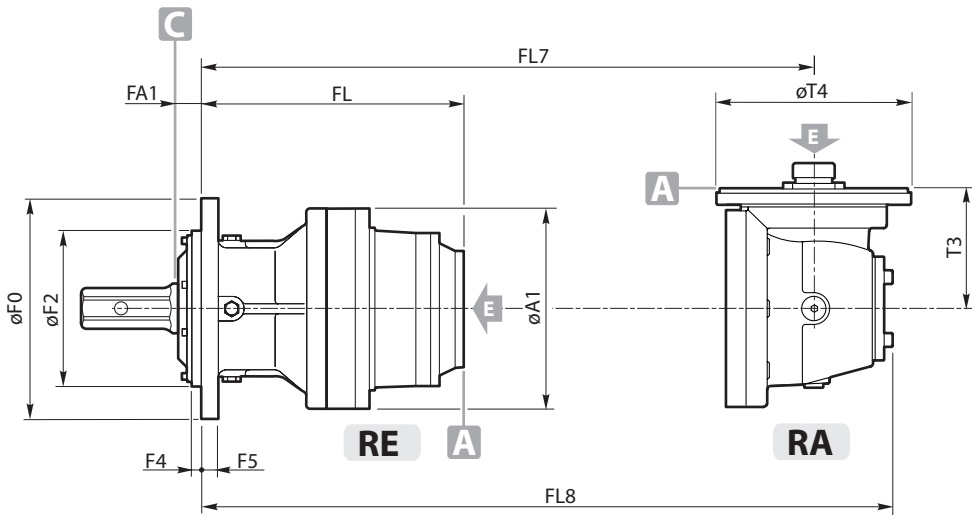
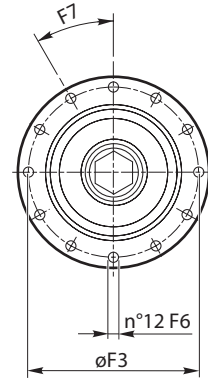

**1020 - 1520  
2000 - 2000L**

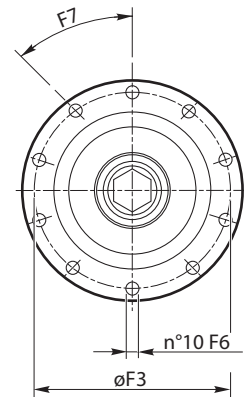

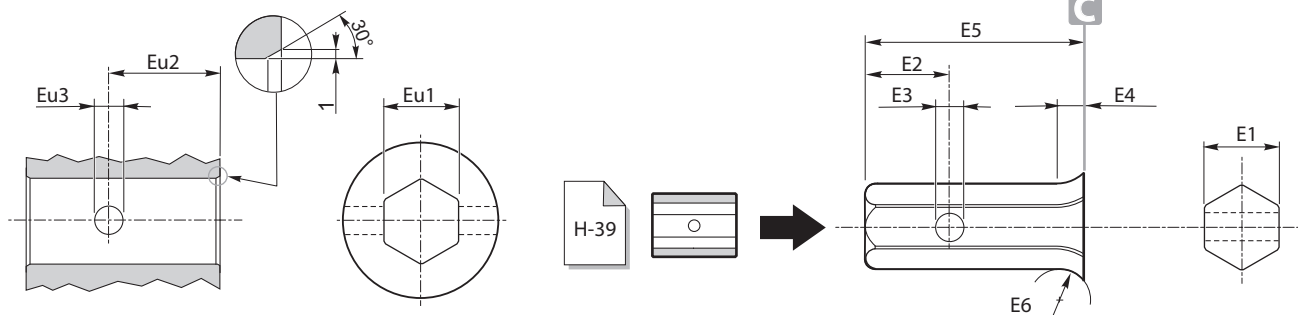

	RE - RA				
	1520	2000	2000L	2520	3000
<b>E1</b>	70	70	70	100	100
<b>E2</b>	65	65	65	170.5	170.5
<b>E3</b>	Ø 22	Ø 22	Ø 22	Ø 32	Ø 32
<b>E4</b>	25	25	25	20	20
<b>E5</b>	142.5	142.5	142.5	160	160
<b>E6</b>	r 30	r 30	r 30	r 35	r 35
<b>Eu1</b>	70	70	70	100	100
<b>Eu2</b>	50	50	50	65	65
<b>Eu3</b>	Ø 22	Ø 22	Ø 22	Ø 32	Ø 32

	stages	RE - RA				
		1520	2000	2000L	2520	3000
<b>A1</b>		350	350	350	409	409
<b>FA1</b>		176.5	176.5	176.5	210	210
<b>F2</b>		278 f7	278 f7	278 f7	340 f7	340 f7
<b>F3</b>		314	314	314	370	370
<b>F4</b>		10	10	10	17	17
<b>F5</b>		133	133	133	131	131
<b>F6</b>		Ø16.5	Ø16.5	Ø16.5	Ø17	Ø17
		M. - 12.9				
		M16	M16	M16	M16	M16
<b>F6A</b>		Ø12	Ø12	Ø12	Ø16	Ø16
<b>F7</b>		15°	15°	15°	12°	12°
<b>F7A</b>		30°	30°	30°	30°	30°
<b>F8</b>		15°	15°	15°	24°	24°
<b>FL</b>	1	107	107	107	98	98
	2	200	200	200	209	226
	3	264.5	258.5	264.5	276	311
	4	307.5	311	307.5	328.5	375.5
<b>FL7</b>	2	313	313	313	292	292
	3	322	322	322	351	368
<b>FL8</b>	4	345.5	380.5	345.5	398	433
	2	441	441	441	420	420
	3	413	413	413	459	476
	4	420	472	420	489	524
<b>G2</b>		225 f7	225 f7	225 f7	245 f7	245 f7
<b>G4</b>		104.5	104.5	104.5	142	142
<b>G5</b>		27.5	27.5	27.5	29	29
<b>H</b>		15	15	15	29	29
<b>T3</b>	2	310	310	310	310	310
	3	171	171	171	227	227
	4	113.8	171	113.8	171	171
<b>T4</b>	2	293	293	293	293	293
	3	183	183	183	242	242
	4	184	183	184	183	183

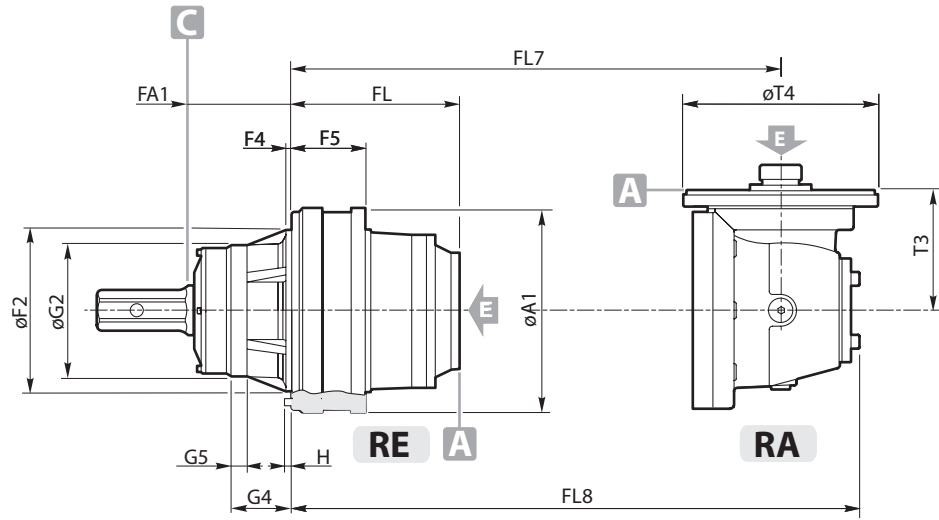

**1520 - 2000  
2000L**

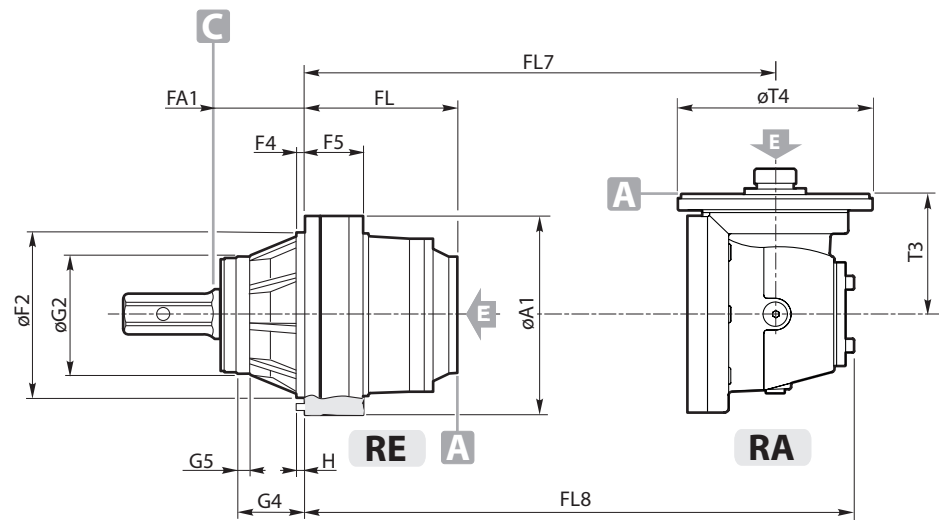
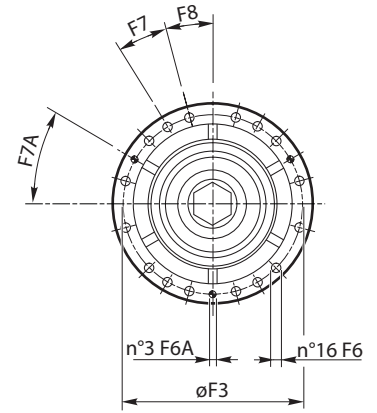

**2520 - 3000**

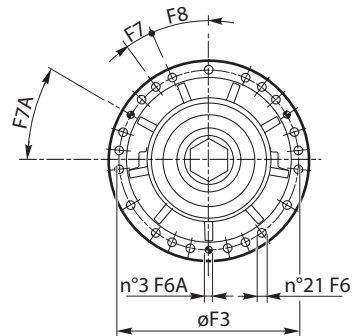

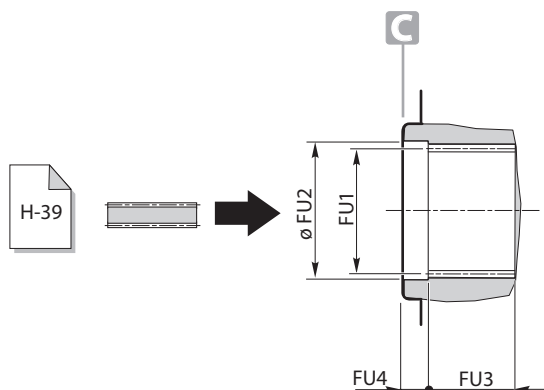

		RE - RA						
		110	210	240	310	510	810	1020
FS	FU1	A 40x36 DIN 5482	A 40x36 DIN 5482	A 45x41 DIN 5482	A 58x53 DIN 5482	A 58x53 DIN 5482	A 70x64 DIN 5482	A 80x74 DIN 5482
	FU2	42 H7	42 H7	46 H7	60 H7	60 H7	72 H7	85 H8
	FU3	29	29	29	41	41	50	59
	FU4	6	6	6	7	7	11.5	10

		RE - RA						
	stages	110	210	240	310	510	810	1020
A1		186	186	186	244	244	295	295
F2		110 h7	110 h7	110 h7	200 h8	200 h8	240 f7	240 f7
F3		165	165	165	222	222	265	265
F4		5	5	5	9	9	10	10
F5		—	—	—	62	80	83	101
F6		Ø10.5	Ø10.5	Ø10.5	Ø10.5	Ø10.5	Ø13	Ø13
		M... - 12.9						
F7		M10	M10	M10	M10	M10	M12	M12
F8		45°	45°	45°	30°	30°	30°	15°
F9		22.5°	22.5°	22.5°	—	—	—	15°
F9		—	—	—	—	—	—	30°
FA1		5	5	5	51	51	50	57
FL	1	59	71	71	39.5	57.5	67	85
	2	102	114	114	92	122	134	170
	3	145	157	157	135	165	186.5	234.5
	4	188	200	200	178	208	229.5	277.5
FL7	2	140	152	152	188.5	179.5	209	227
	3	183	195	195	173	203	256.5	292
	4	226	238	238	216	246	267.5	315.5
FL8	2	214.5	226.5	226.5	252.5	270.5	317	335
	3	257.5	269.5	269.5	247.5	277.5	347.5	383
	4	300.5	312.5	312.5	290.5	320.5	342	390
T3	2	113.8	113.8	113.8	113.8	171.5	277	277
	3	113.8	113.8	113.8	113.8	113.8	171.5	171.5
	4	113.8	113.8	113.8	113.8	113.8	113.8	113.8
T4	2	184	184	184	184	183	242	242
	3	184	184	184	184	184	183	183
	4	184	184	184	184	184	184	184





**110 - 210 - 240**

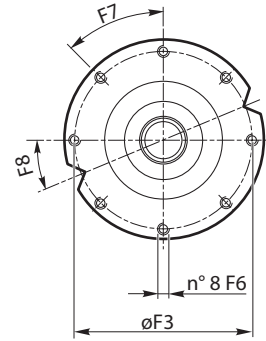
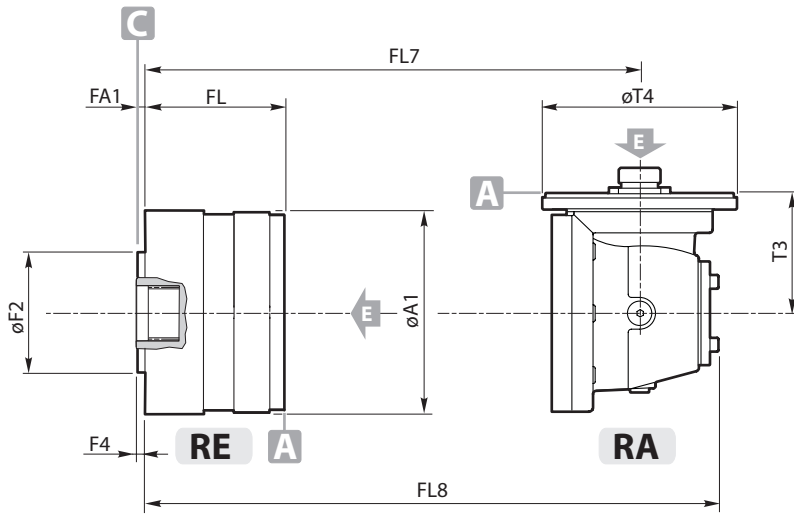

**310 - 510 - 810**

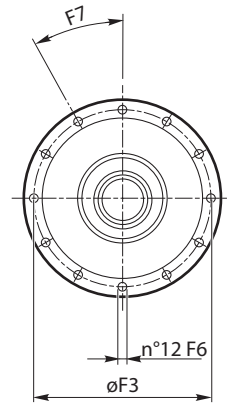
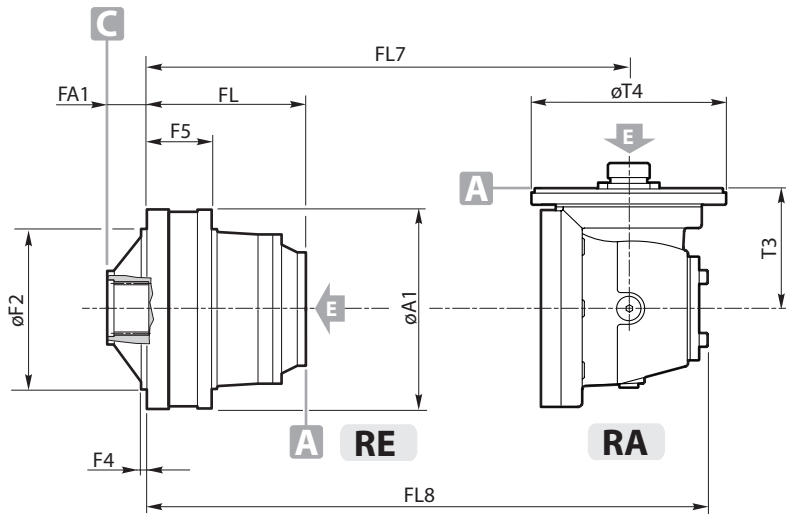

**1020**

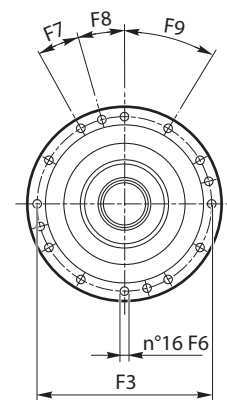
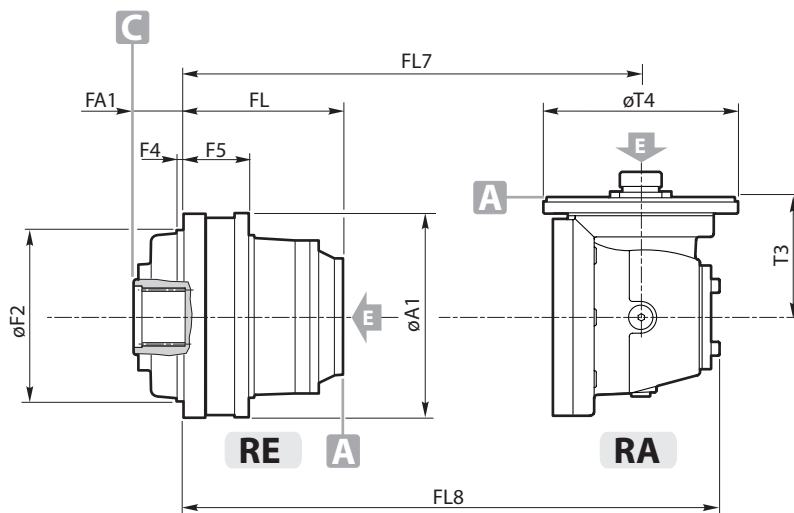

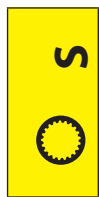
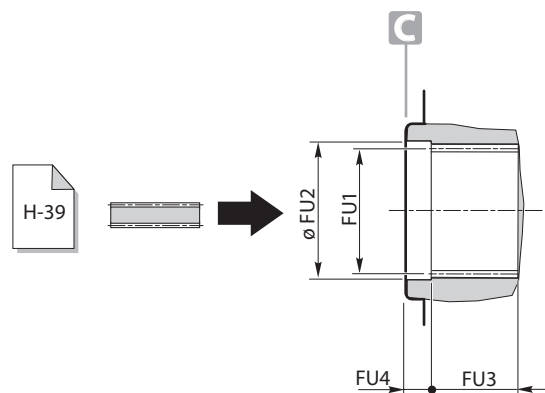

		RE - RA						
		1520	2000	2000L	2520	3000	3510	4800
FS	FU1	A 80x74 DIN 5482	A 80x74 DIN 5482"	A 80x74 DIN 5482"	A 100x94 DIN 5482"	A 100x94 DIN 5482	N120x3x9H DIN5480	N120x3x9H DIN5480
	FU2	88 H8	88 H8	88 H8	102 H8	102 H8	121.5 H7	121.5 H7
	FU3	77	77	77	86	86	85	85
	FU4	7	7	7	10	10	10	10

		RE - RA						
	stages	1520	2000	2000L	2520	3000	3510	4800
A1		350	350	350	409	409	452	452
F2		278 f7	278 f7	278 f7	340 f7	340 f7	390 f7	390 f7
F3		314	314	314	370	370	424	424
F4		12	12	12	18	18	15	15
F5		103.5	103.5	103.5	126	126	120	120
F6		Ø16.5	Ø16.5	Ø16.5	Ø17	Ø17	Ø17	Ø17
		M16	M16	M16	M16	M16	M16	M16
F6A		Ø12	Ø12	Ø12	Ø16	Ø16	—	—
F7		15°	15°	15°	24°	24°	20°	20°
F7A		30°	30°	30°	30°	30°	—	—
F8		30°	30°	30°	12°	12°	10°	10°
F9		15°	15°	15°	12°	12°	—	—
F10		15	15	15	34	34	—	—
FA1		83	83	83	95	95	109.5	109.5
FL	1	77.5	77.5	77.5	93	93	85	85
	2	170.5	170.5	170.5	204	221	277	326
	3	235	229	235	271	306	362	419
	4	278	281.5	278	323.5	370.5	426.5	483.5
FL7	2	283.5	283.5	283.5	287	287	339	339
	3	292.5	292.5	292.5	346	363	419	532
	4	316	351	316	393	428	484	541
FL8	2	411.5	411.5	411.5	415	415	529	529
	3	383.5	383.5	383.5	454	471	527	660
	4	390.5	442	390.5	484	519	575	632
T3	2	310	310	310	310	310	432	432
	3	171	171	171	227	227	227	310
	4	113.8	171	113.8	171	171	171	171
T4	2	293	293	293	293	293	295	295
	3	183	183	183	242	242	242	293
	4	184	183	184	183	183	183	183

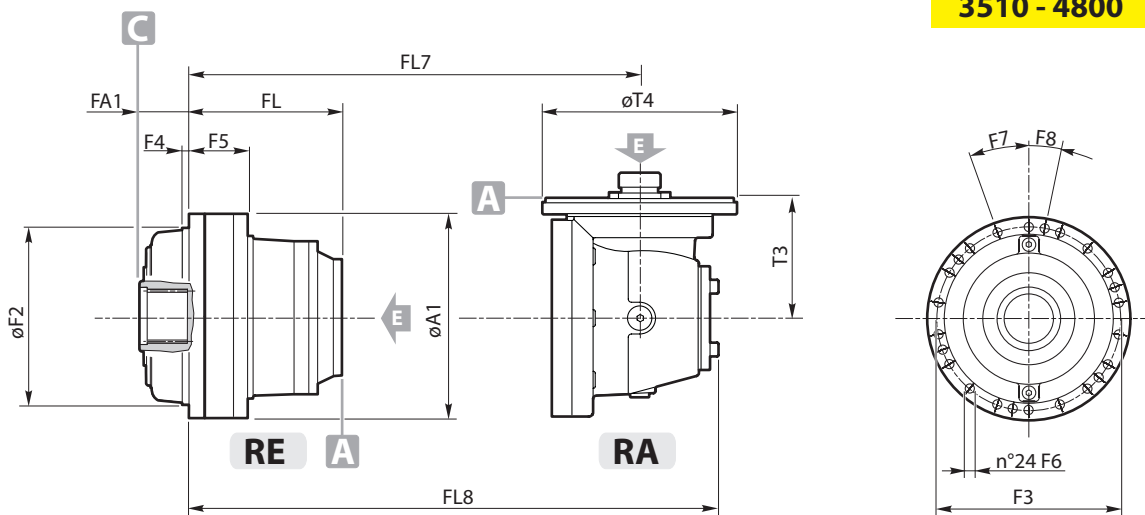
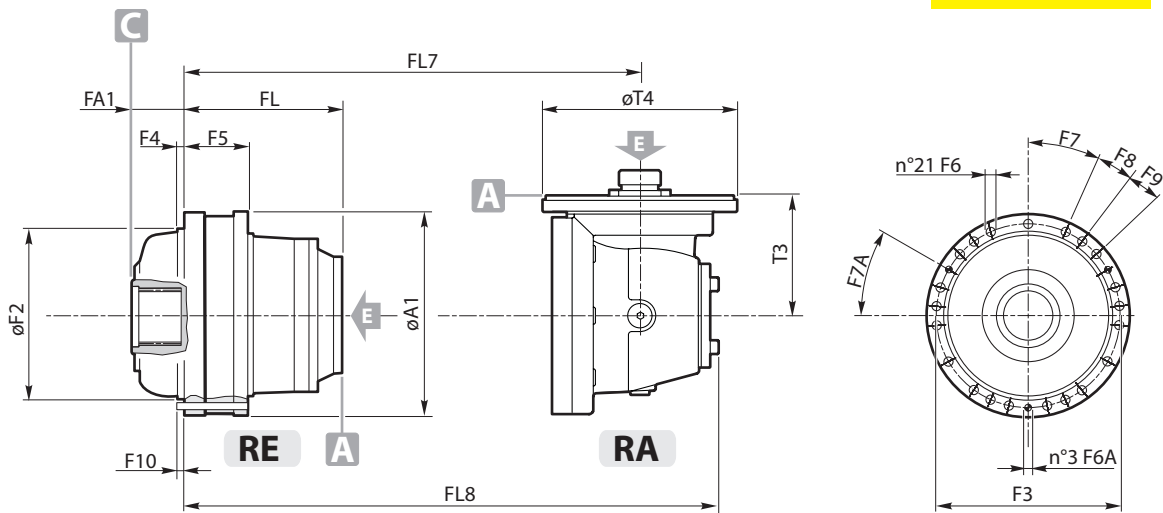
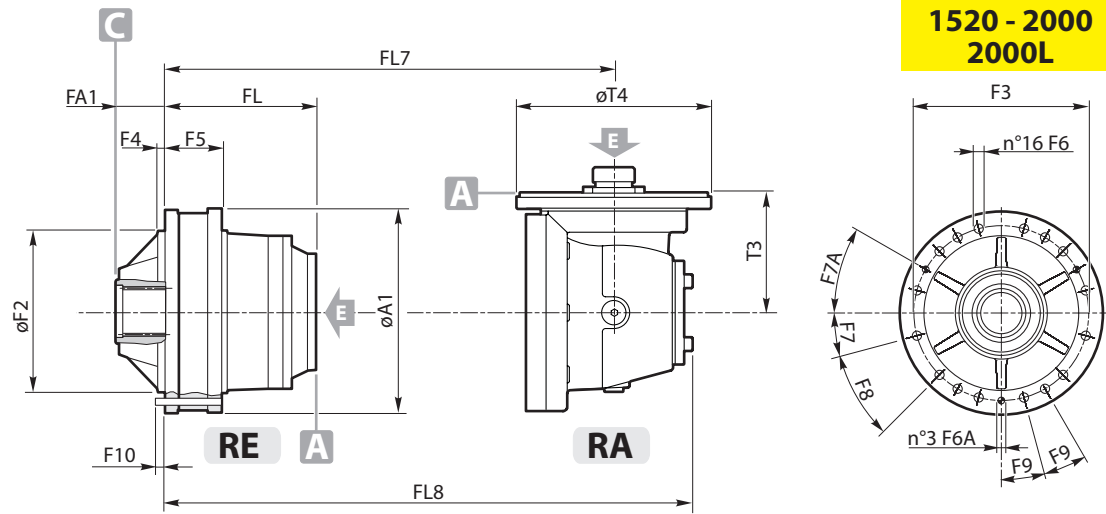

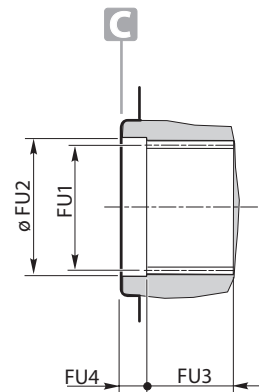
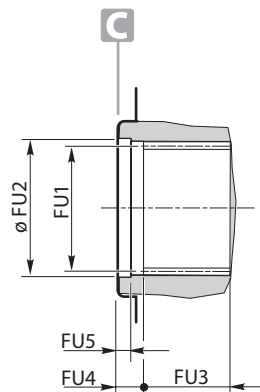

FS	RE - RA		GB - GBA	
	6000	8000	12010	16000
FU1	N140x5x9H DIN 5480	N140x5x9H DIN 5480	N160x5x9H DIN 5480	N160x5x9H DIN 5480
FU2	142 H9	142 H9	165 H7	165 H7
FU3	97	122	100	100
FU4	—	—	40	40
FU5	12	12	20	20

FS1	RE - RA		GB - GBA	
	6000	8000	12010	16000
FU1	N150x5x9H DIN 5480	N150x5x9H DIN 5480	—	—
FU2	152 H7	152 H7	—	—
FU3	74	74	—	—
FU4	41	41	—	—
FU5	20	20	—	—

FS4	RE - RA		GB - GBA	
	6000	8000	12010	16000
FU1	—	—	N180x5x9H DIN 5480	N180x5x9H DIN 5480
FU2	—	—	185 H7	185 H7
FU3	—	—	100	100
FU4	—	—	—	—
FU5	—	—	40	40

	stages	RE - RA		GB - GBA	
		6000	8000	12010	16000
A1		490	490	610	610
F2		410 f7	410 h8	515 h8	515 h8
F3		445	445	560	560
F4		15	15	20	20
F5		178.5	181.5	230	230
F6		Ø19	Ø19	Ø25	Ø25
		M18		M24	
F7		7°30'	7°30'	15°	15°
F8		15°	15°	7°30'	7°30'
F9		7°30'	7°30'	7°30'	7°30'
FA1	FS	100	125	152	152
	FS1	106	125	—	—
	FS4	—	—	152	152
FL	1	136.5	136.5	160.5	160.5
	2	305	390.5	410	427
	3	398	518.5	538	668
	4	456.5	603.5	623	761
	5	—	668	687.5	825.5
FL7	2	390.5	390.5	—	—
	3	511	584.5	604	681
	4	520	660.5	680	874
FL8	2	580.5	580.5	—	—
	3	639	712.5	732	871
	4	611	768.5	788	1002
T3	2	432	432	—	—
	3	310	310	310	432
	4	171	227	227	310
T4	2	295	295	—	—
	3	293	293	293	295
	4	183	242	242	293
	5	—	—	183	183

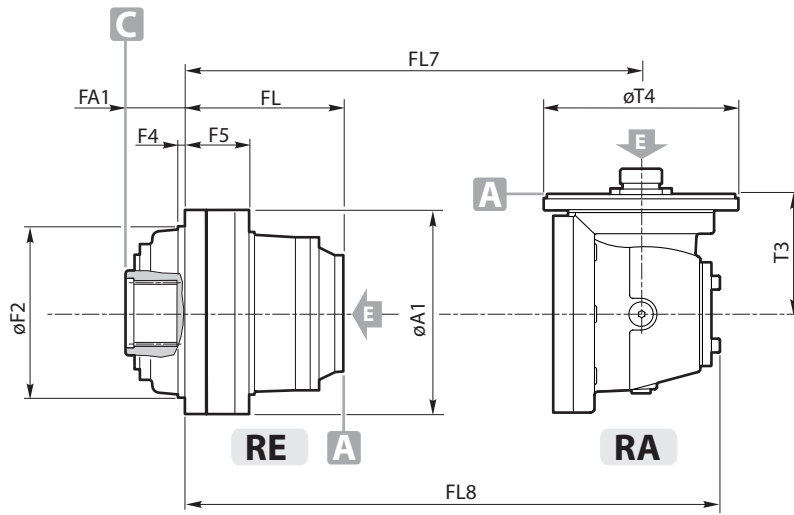

**6000 - 8000**

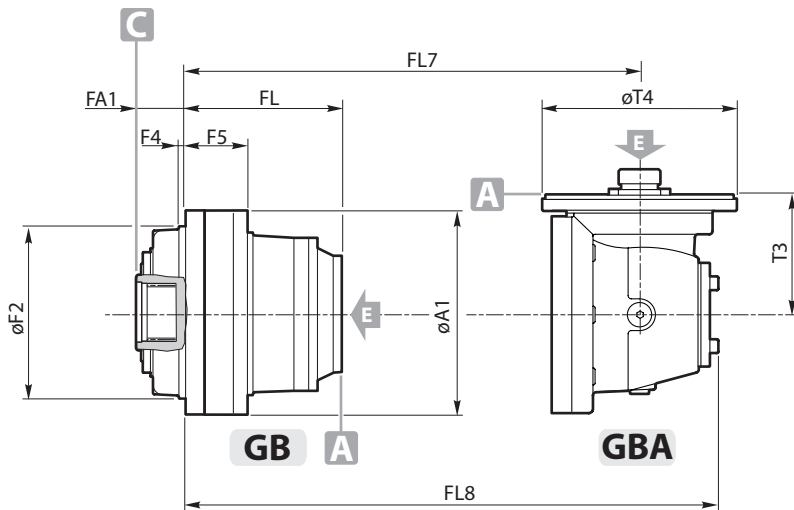
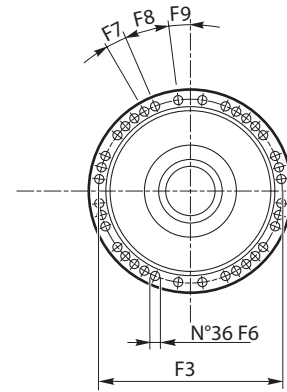

**12010 - 16000**

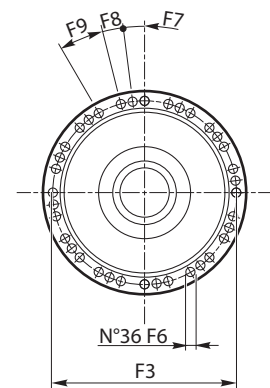

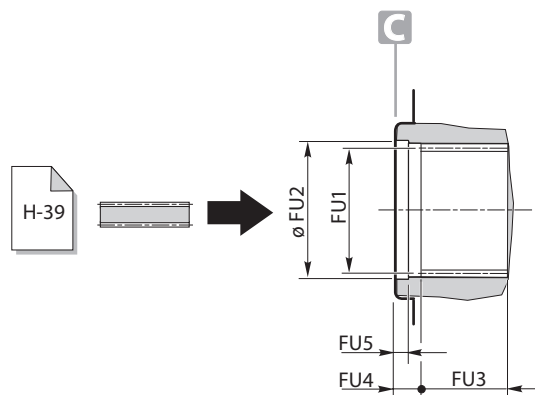

		RE - RA		GB - GBA	
		6000L	8000L	12010L	16000L
<b>FS</b>	<b>FU1</b>	N140x5x9H DIN 5480	N140x5x9H DIN 5480	N160x5x9H DIN 5480	N160x5x9H DIN 5480
	<b>FU2</b>	142 H9	142 H9	165 H7	165 H7
	<b>FU3</b>	97	122	100	100
	<b>FU4</b>	—	—	40	40
	<b>FU5</b>	12	12	20	20

		RE - RA		GB - GBA	
		6000L	8000L	12010L	16000L
<b>FS1</b>	<b>FU1</b>	N150x5x9H DIN 5480	N150x5x9H DIN 5480	—	—
	<b>FU2</b>	152 H7	152 H7	—	—
	<b>FU3</b>	74	74	—	—
	<b>FU4</b>	41	41	—	—
	<b>FU5</b>	20	20	—	—

		RE - RA		GB - GBA	
		6000L	8000L	12010L	16000L
<b>FS4</b>	<b>FU1</b>	—	—	N180x5x9H DIN 5480	N180x5x9H DIN 5480
	<b>FU2</b>	—	—	185 H7	185 H7
	<b>FU3</b>	—	—	100	100
	<b>FU4</b>	—	—	40	40
	<b>FU5</b>	—	—	—	—

		RE - RA		GB - GBA	
		6000L	8000L	12010L	16000L
<b>A1</b>	stages	490	490	610	610
<b>F2</b>		410 f7	410 h8	515 h8	515 h8
<b>F3</b>		445	445	560	560
<b>F4</b>		15	15	20	20
<b>F5</b>		178.5	181.5	230	230
<b>F6</b>		Ø19	Ø19	Ø25	Ø25
		M18	M18	M24	M24
<b>F7</b>		7°30'	7°30'	15°	15°
<b>F8</b>		15°	15°	7°30'	7°30'
<b>F9</b>		7°30'	7°30'	7°30'	7°30'
<b>FA1</b>	FS	100	100	152	152
	FS1	106	106	—	—
	FS4	—	—	152	152
<b>FL</b>	1	136.5	136.5	160.5	160.5
	2	305	390.5	410	427
	3	398	501.5	521	619
	4	462.5	568.5	588	704
	5	—	621	640.5	768.5
<b>FL7</b>	2	390.5	390.5	—	—
	3	511	584.5	604	681
	4	520	643.5	663	761
	5	—	—	710	826
<b>FL8</b>	2	580.5	580.5	—	—
	3	639	712.5	732	871
	4	611	751.5	771	869
	5	—	—	801	917
<b>T3</b>	2	432	432	—	—
	3	310	310	310	432
	4	171	227	227	310
	5	—	—	171	171
<b>T4</b>	2	295	295	—	—
	3	293	293	293	295
	4	183	242	242	293
	5	—	—	183	183

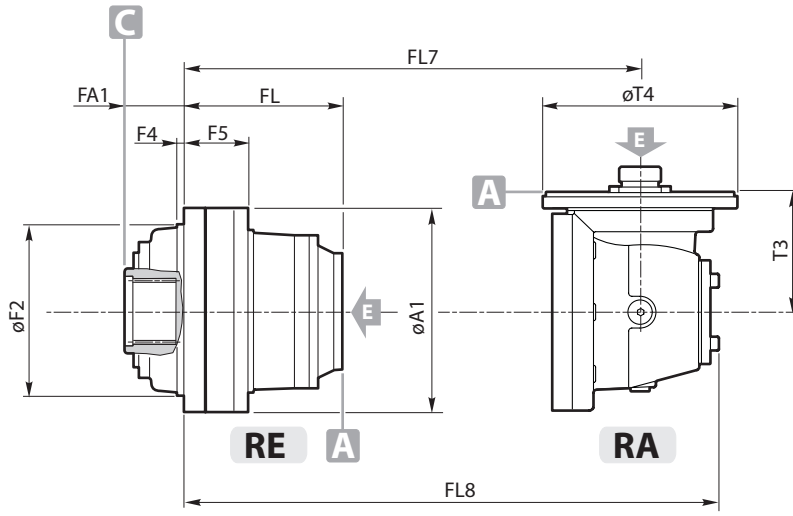

**6000L - 8000L**

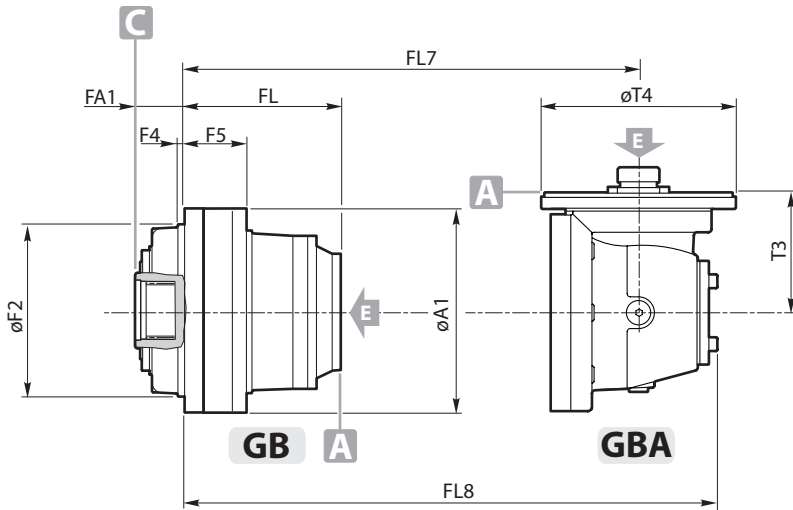
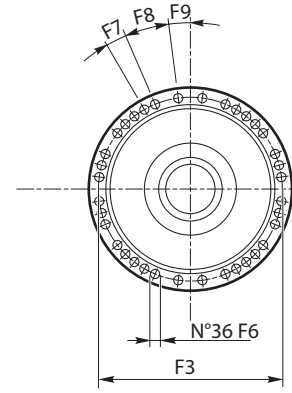

**12010L - 16000L**

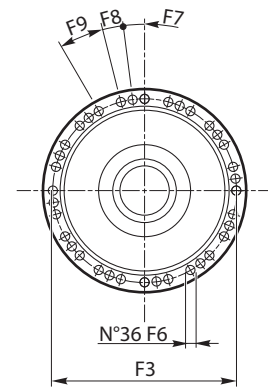

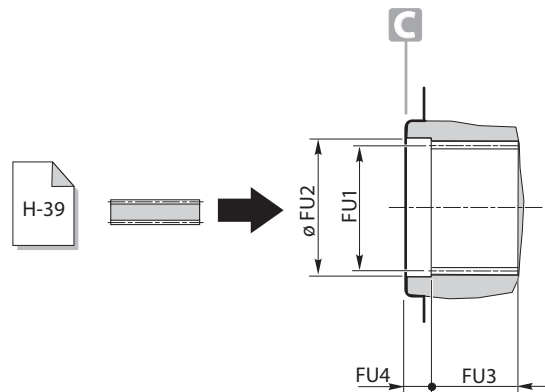

		GB - GBA							
		21000	26000	31000	40000	45000	53000	61000	85000
<b>FS</b>	<b>FU1</b>	N200x5x9H DIN 5480	N220x5x9H DIN 5480	N240x5x9H DIN 5480	N240x5x9H DIN 5480	N280x6x9H DIN 5480	N300x8x9H DIN 5480	N300x8x9H DIN 5480	N340x8x9H DIN 5480
	<b>FU2</b>	202 H7	222 H7	242 H7	242 H7	281 H8	303 H7	303 H7	343 H7
	<b>FU3</b>	120	120	170	170	175	190	190	190
	<b>FU4</b>	38	38	50	50	50	70	70	70

		GB - GBA							
stages		21000	26000	31000	40000	45000	53000	61000	85000
<b>A1</b>		710	710	870	870	870	1090	1090	1090
<b>F2</b>		600 h8	600 h8	760 h8	760 h8	760 h8	930 h8	930 h8	930 h8
<b>F3</b>		660	660	810	810	810	1020	1020	1020
<b>F4</b>		23.5	23.5	35	35	35	50	50	50
<b>F5</b>		196	216	250	290	290	305	305	353
<b>F6</b>		Ø28	Ø28	Ø32	Ø32	Ø32	Ø39	Ø39	Ø39
		M... - 10.9							
		M27	M27	M30	M30	M30	M36	M36	M36
<b>F7</b>		10°	10°	10°	10°	10°	10°	10°	10°
<b>FA1</b>		185	185	255	255	260	300	300	300
<b>FL</b>	1	138	158	180	220	220	225	225	273
	2	443	463	588.5	628.5	628.5	700	700	768
	3	611.5	717	838	878	895	1005	1005	1073
	4	704.5	845	966	1006	1136	1173.5	1173.5	1327
	5	763	930	1051	1091	1229	1266.5	1266.5	1455
<b>FL7</b>	3	697	717	—	—	—	—	—	—
	4	817.5	911	1032	1072	1149	1259	1259	1327
	5	826.5	987	1108	1148	1342	1379.5	1379.5	1521
	6	—	—	—	—	—	—	1388.5	1597
<b>FL8</b>	3	887	907	—	—	—	—	—	—
	4	945.5	1039	1160	1200	1339	1449	1449	1517
	5	917.5	1095	1216	1256	1470	1507.5	1507.5	1649
	6	—	—	—	—	—	—	1479.5	1705
<b>T3</b>	3	432	432	—	—	—	—	—	—
	4	310	310	310	310	432	432	432	432
	5	171	227	227	227	310	310	310	310
	6	—	—	—	—	—	—	171	171
<b>T4</b>	3	295	295	—	—	—	—	—	—
	4	293	293	293	293	295	295	295	295
	5	183	242	242	242	293	293	293	293
	6	—	—	—	—	—	—	183	183

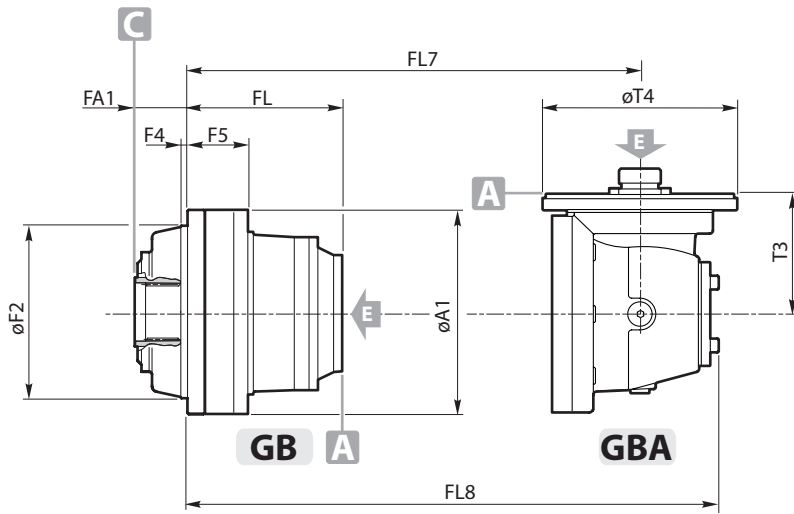

**21000 - 26000**

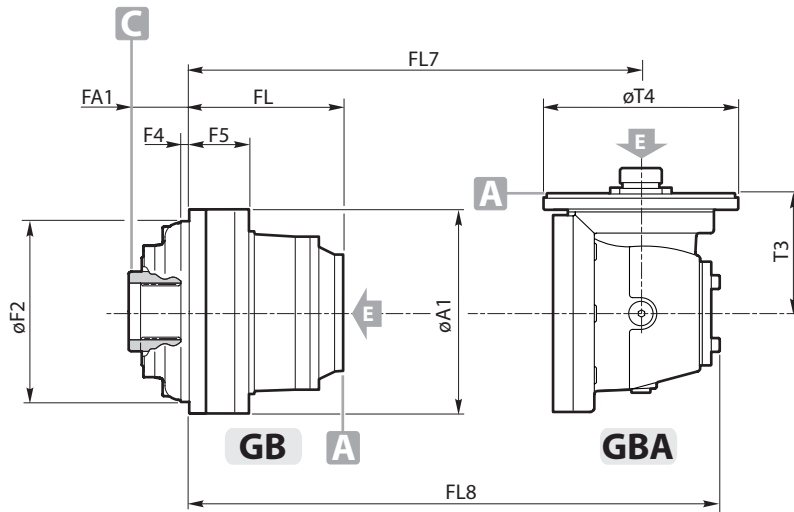
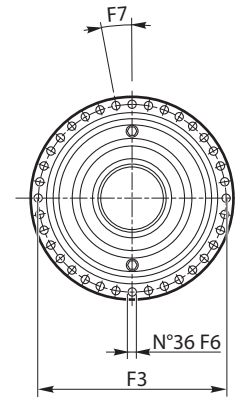

**31000 ÷ 45000**

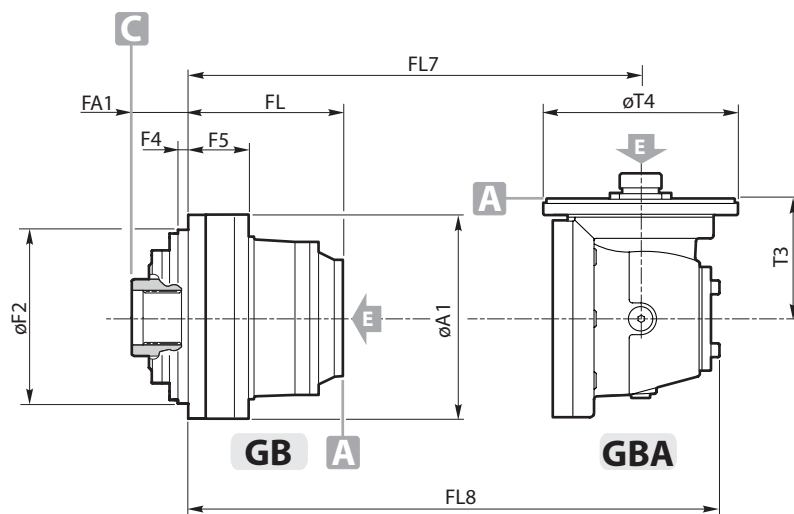
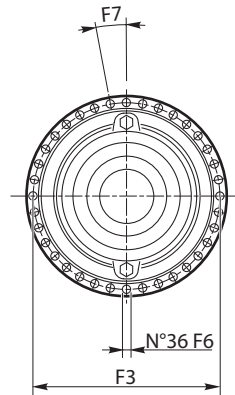

**53000 ÷ 85000**

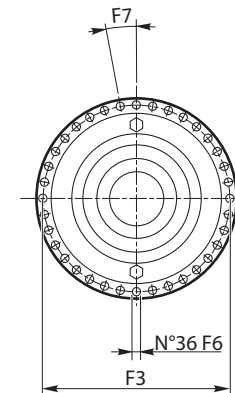

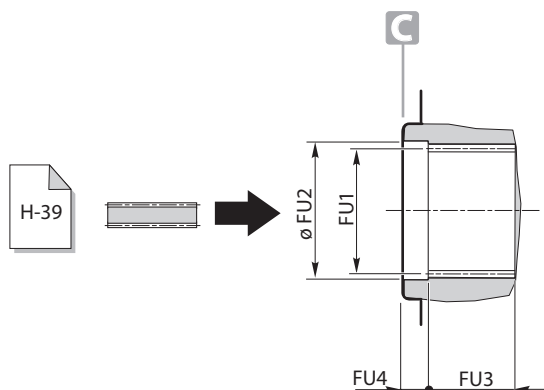

GB - GBA						
	110000	130000	150000	205000	235000	
<b>FS</b>	<b>FU1</b>	N420x8x9H DIN 5480	N420x8x9H DIN 5480	N420x8x9H DIN 5480	N500x8x9H DIN 5480	N500x8x9H DIN 5480
	<b>FU2</b>	430 H7	430 H7	430 H7	510 H8	510 H8
	<b>FU3</b>	210	210	210	265	265
	<b>FU4</b>	80	80	80	73	73

GB - GBA						
	stages	110000	130000	150000	205000	235000
<b>A1</b>		1320	1320	1320	1630	1630
<b>F0</b>		1538	1538	1538	1880	1880
<b>F2</b>		1150 h9	1150 h9	1150 h9	1440 h8	1440 h8
<b>F3</b>		1450	1450	1450	1780	1780
<b>F4</b>		80	80	80	80	80
<b>F5</b>		110	110	110	110	110
<b>F6</b>		Ø44 (x40)	Ø44 (x40)	Ø44 (x40)	Ø44 (x48)	Ø44 (x48)
		M.. - 10.9				
		M42	M42	M42	M42	M42
<b>F7</b>		9°	9°	9°	7°30'	7°30'
<b>FA1</b>		402.5	402.5	402.5	375	375
<b>FL</b>	1	315	315	315	303	303
	2	966.5	966.5	966.5	1016	1016
	3	1375	1375	1375	1511	1590.5
	4	1624.5	1641.5	1721.5	1852	1986.5
	5	1752.5	1882.5	1890	2101.5	2236
<b>FL7</b>	5	1818.5	1895.5	—	—	—
	6	1894.5	2088.5	—	—	—
<b>FL8</b>	5	1946.5	2085.5	—	—	—
	6	2002.5	2216.5	—	—	—
<b>T3</b>	5	310	432	—	—	—
	6	227	310	—	—	—
<b>T4</b>	5	293	295	—	—	—
	6	242	293	—	—	—

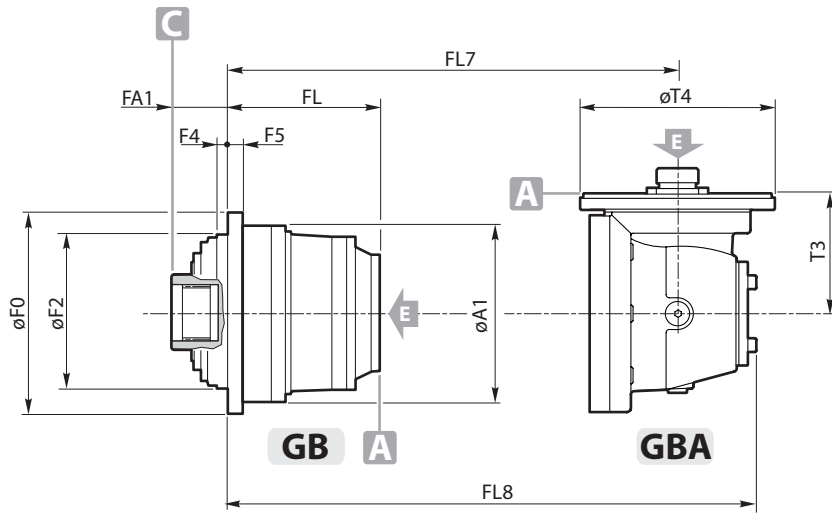

**110000 ÷ 235000**

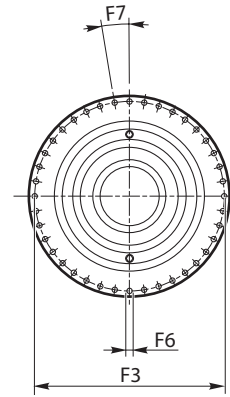

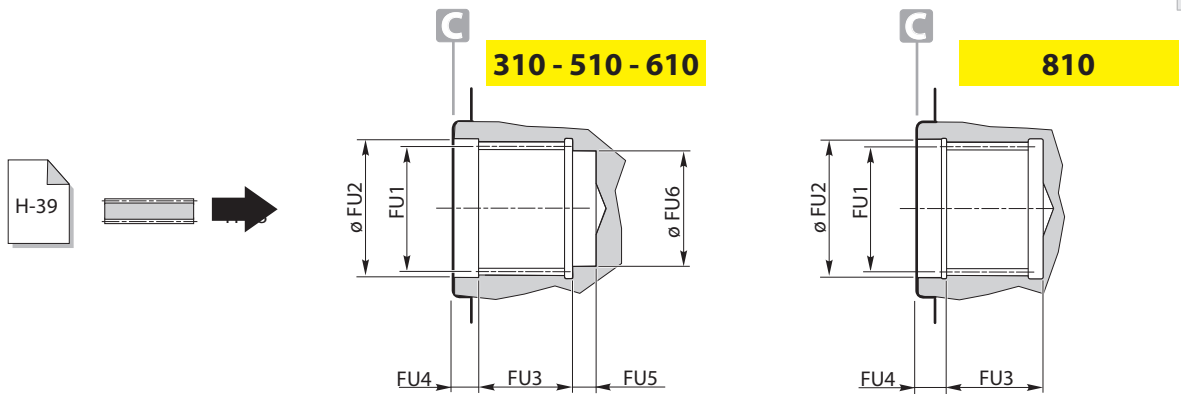

		RE - RA			
		310	510	610	810
NF	FU1	A 58x53 DIN 5482	A 58x53 DIN 5482	A 58x53 DIN 5482	A 70x64 DIN 5482
	FU2	60 H8	60 H8	60 H8	72 H8
	FU3	29	29	29	45
	FU4	15	15	15	22
	FU5	10	10	10	—
	FU6	50 H8	50 H8	50 H8	—

		RE - RA			
		310	510	610	810
A1	stages	244	244	244	295
F0		222	222	222	280
F2		150 f7	150 f7	150 f7	200 f7
F3		195	195	195	250
F4		13.5	13.5	13.5	10.5
F5		16	16	16	18
F6		Ø12.5	Ø12.5	12.5	Ø15
		M... - 12.9			
F7		M12	M12	M12	M14
F7		36°	36°	36°	30°
FA1		15	15	15	40
FL	1	133	151	151	162.5
	2	185.5	215.5	209.5	229.5
	3	228.5	258.5	262	282
	4	271.5	301.5	305	325
FL7	2	255	273	273	304.5
	3	266.5	296.5	331.5	351.5
	4	309.5	339.5	343	363
FL8	2	346	364	364	412.5
	3	341	371	422.5	442.5
	4	384	414	417.5	437.5
T3	2	171.5	171.5	171.5	277
	3	113.8	113.8	171.5	171.5
	4	113.8	113.8	113.8	113.8
T4	2	183	183	183	242
	3	184	184	183	183
	4	184	184	184	184



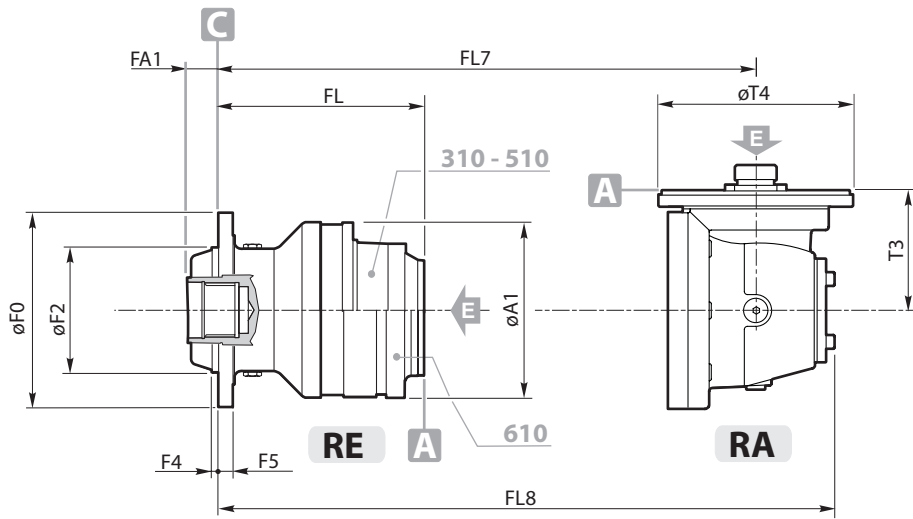

**310 - 510 - 610**

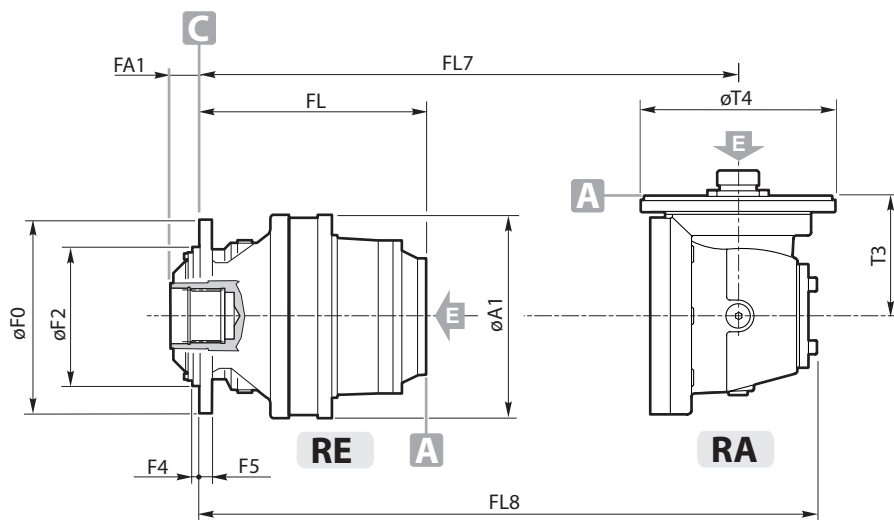
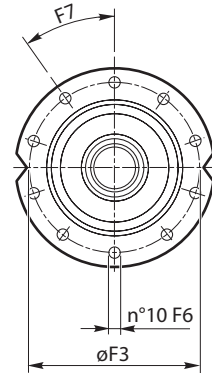

**810**

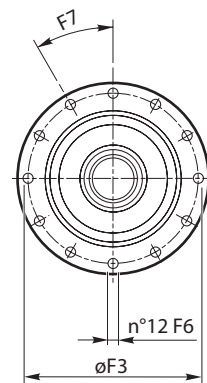

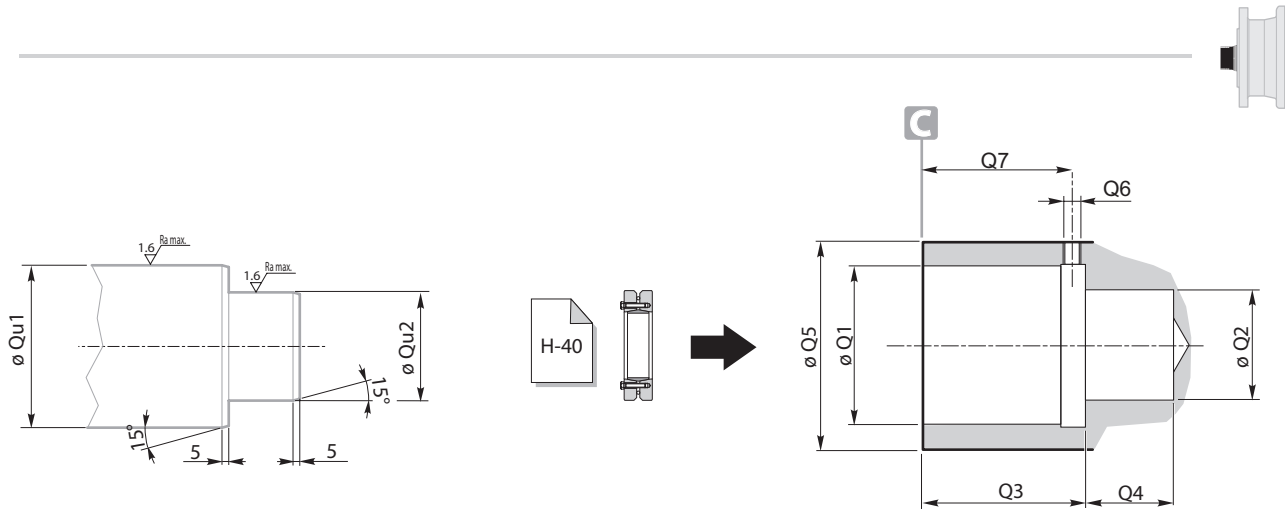

NQ	RE - RA				
		110	210	310	510
	Q1	50 H7	50 H7	75 H7	75 H7
	Q2	30 H7	30 H7	40 H7	40 H7
	Q3	38	38	55	55
	Q4	12	12	20	20
	Q5	62 f7	62 f7	100 f7	100 f7
	Q6	—	—	1/8"G	1/8"G
Q7	—	—	52	52	
Qu1	50 g6	50 g6	75 g6	75 g6	
Qu2	30 f6	30 f6	40 f6	40 f6	

		RE - RA				
	stages	110	210	310	510	610
A1		186	186	244	244	244
F0		185	185	222	222	222
F2		110 h7	110 h7	150 f7	150 f7	150 f7
F3		165	165	195	195	195
F4		5	5	13.5	13.5	13.5
F5		12	12	16	16	16
F6		10.5	10.5	12.5	12.5	12.5
		M... - 12.9				
F7		M10	M10	M12	M12	M12
F8		45°	45°	36°	36°	36°
FA1		22.5°	22.5°	—	—	—
FL		55	55	87	87	87
	1	95	107	133	151	151
	2	138	150	185.5	215.5	209.5
	3	181	193	228.5	258.5	262
FL7	4	224	236	271.5	301.5	305
	2	176	188	255	273	273
FL8	3	219	231	266.5	296.5	331.5
	4	262	274	309.5	339.5	343
	2	250.5	262.5	346	364	364
T3	3	293.5	305.5	341	371	422.5
	4	336.5	348.5	384	414	417.5
	2	113.8	113.8	171.5	171.5	171.5
T4	3	113.8	113.8	113.8	113.8	171.5
	4	113.8	113.8	113.8	113.8	113.8
	2	184	184	183	183	183
T4	3	184	184	184	184	183
	4	184	184	184	184	184





**110 ÷ 510**

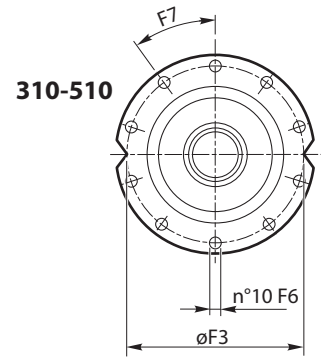
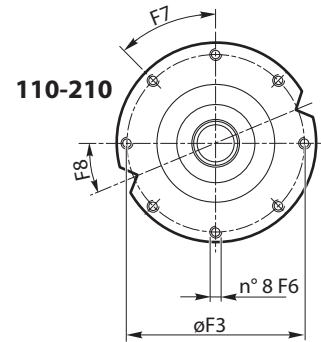
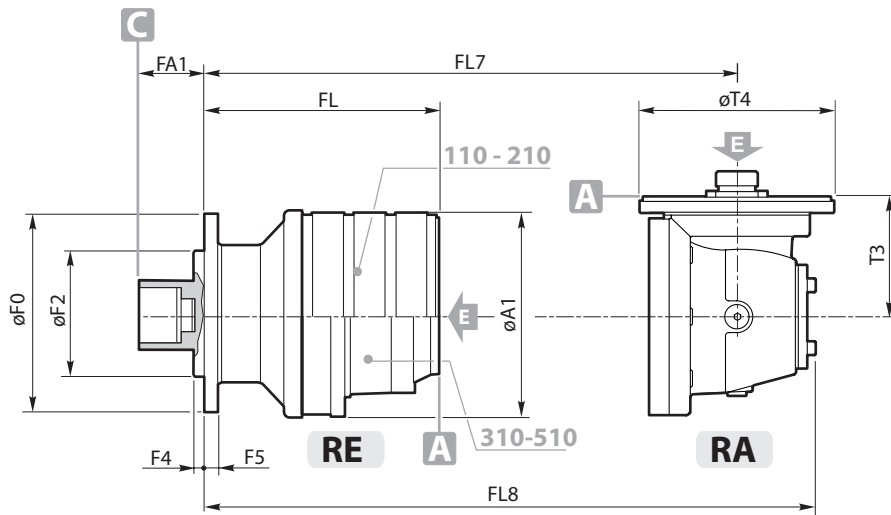

**610**

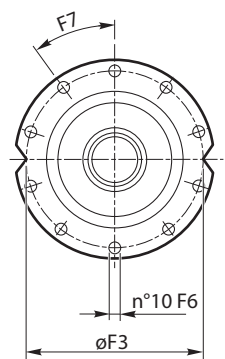
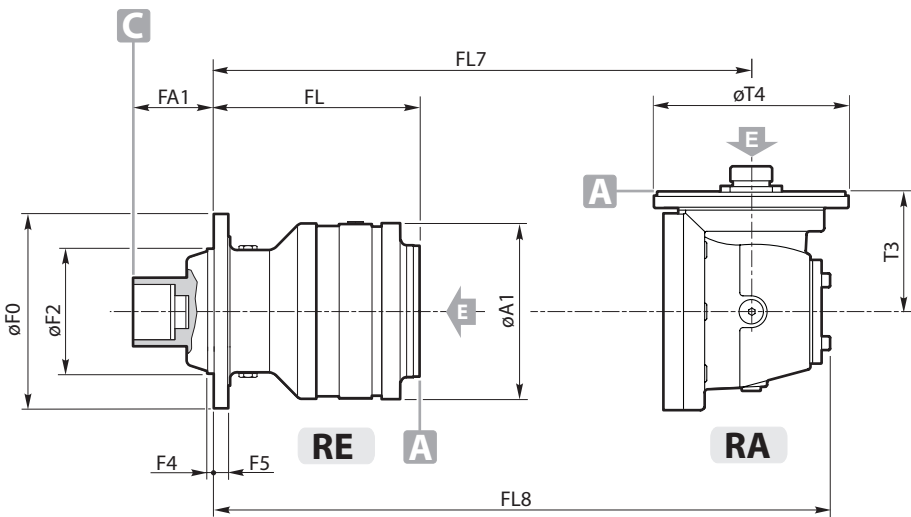

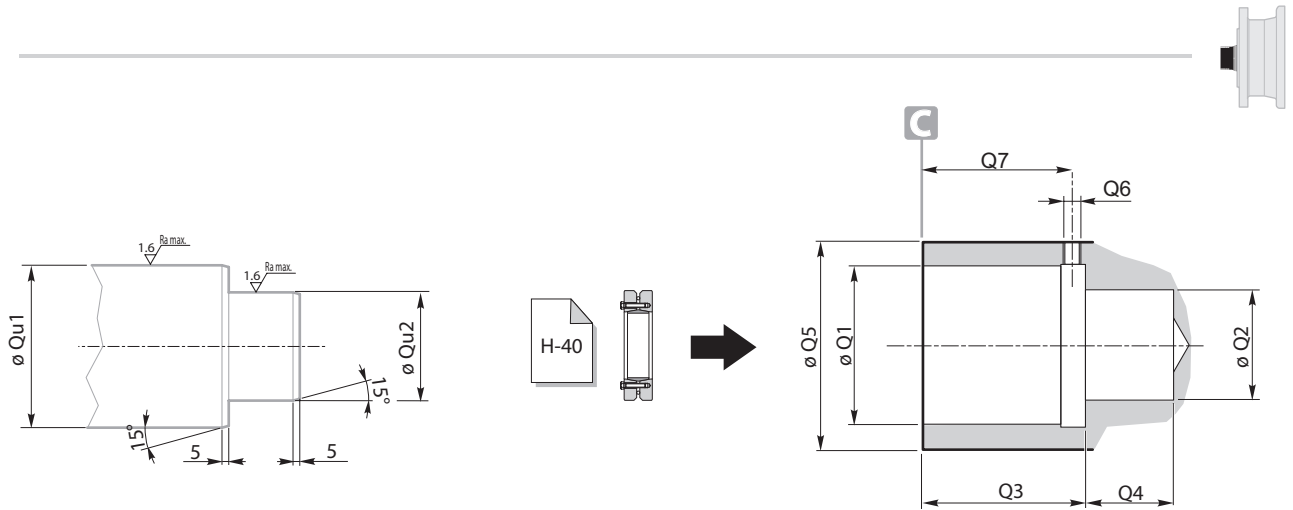

		RE - RA					
		240		810	1020	1520	2000 2000L
TQ TRQ	Q1	75 H7	75 H7	90 H7	120 H7	120 H7	120 H7
	Q2	40 H7	40 H7	50 H7	80 H7	80 H7	80 H7
	Q3	55	55	72	85	85	85
	Q4	17	17	25	30	30	30
	Q5	100 f7	100 f7	125 f7	165 f7	165 f7	165 f7
	Q6	—	—	1/8"G	1/8"G	1/8"G	1/8"G
	Q7	—	—	81.5	97.5	97.5	97.5
	Qu1	75 g6	75 g6	90 g6	120 g6	120 g6	120 g6
	Qu2	40 f6	40 f6	50 f6	80 f6	80 f6	80 f6

		RE - RA						
		240		810	1020	1520	2000	2000L
stages		TQ	TRQ	TQ	TQ	TQ	TQ	TQ
	A1		186	186	295	295	350	350
F0		219	219	280	325	325	325	325
F2		150 h7	155 f7	200 f7	230 f7	230 f7	230 f7	230 f7
F3		195	194	250	295	295	295	295
F4		7	10	10.5	15	15	15	15
F5		15	15	22	25	28	28	28
F6		$\varnothing 12.5$	$\varnothing 11$	$\varnothing 15$	$\varnothing 17$	$\varnothing 17$	$\varnothing 17$	$\varnothing 17$
		M12	M10	M14	M16	M16	M16	M16
F7		36°	36°	30°	36°	36°	36°	36°
FA1		87	104	131	140	140	140	104
FL	1	114	97	185	237	240	240	240
	2	157	140	252	322	333	333	333
	3	200	183	304.5	386.5	397.5	391.5	397.5
	4	243	226	347.5	429.5	440	444	440
FL7	2	195	178	326.5	379	446	446	446
	3	238	221	374	444	455	455	455
FL8	2	269.5	252.5	435	487	574	574	574
	3	312.5	295.5	465	535	546	546	546
	4	355.5	338.5	460	542	553	604.5	553
T3	2	113.8	113.8	277	277	310	310	310
	3	113.8	113.8	171.5	171.5	171.5	171.5	171.5
	4	113.8	113.8	113.8	113.8	113.8	171.5	113.8
T4	2	184	184	242	242	293	293	293
	3	184	184	183	183	183	183	183
	4	184	184	184	184	184	183	184



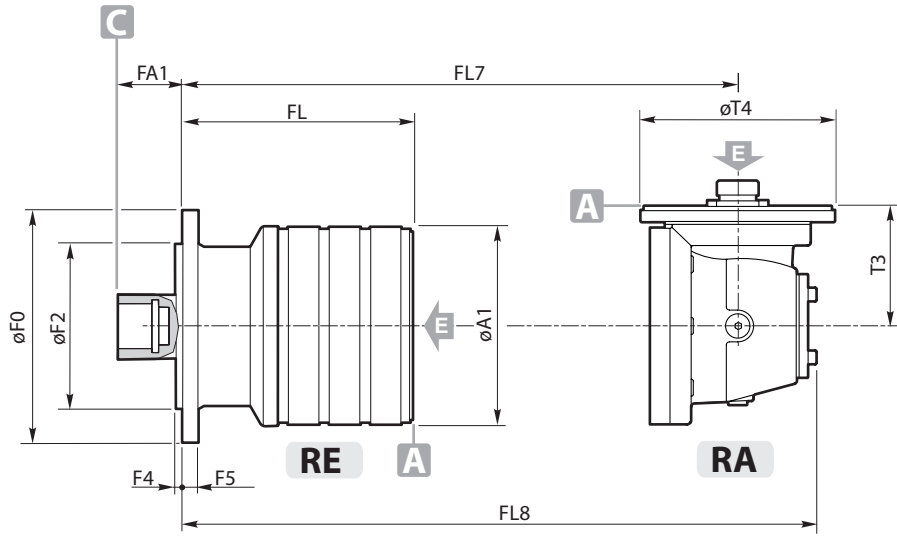

**TQ 240**

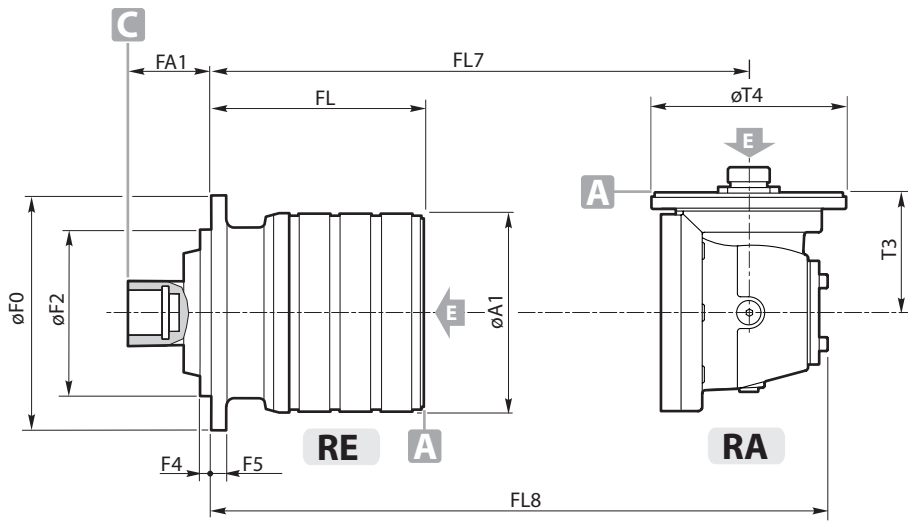
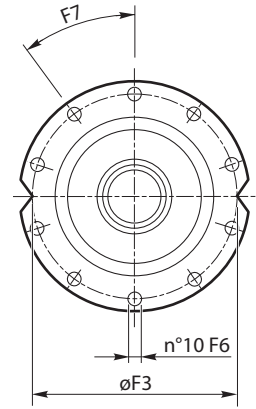

**TRQ 240**

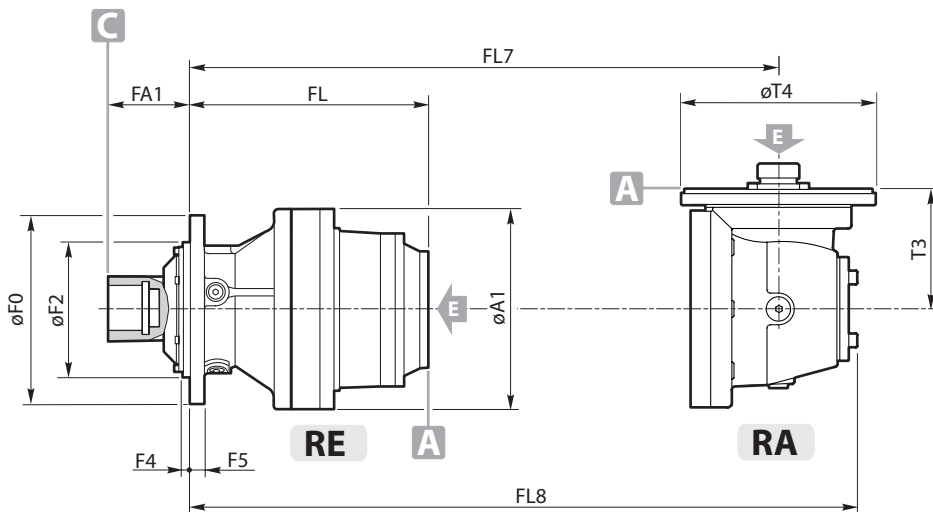
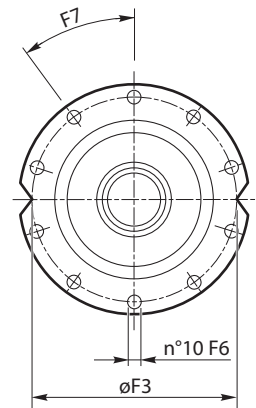

**TQ 810**

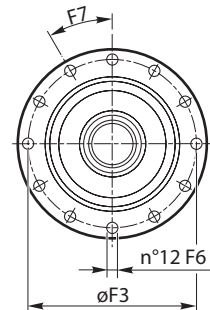

**TQ 1020 ÷ 2000L**

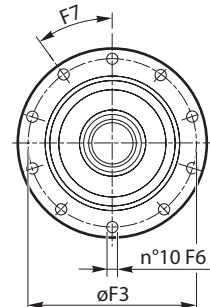

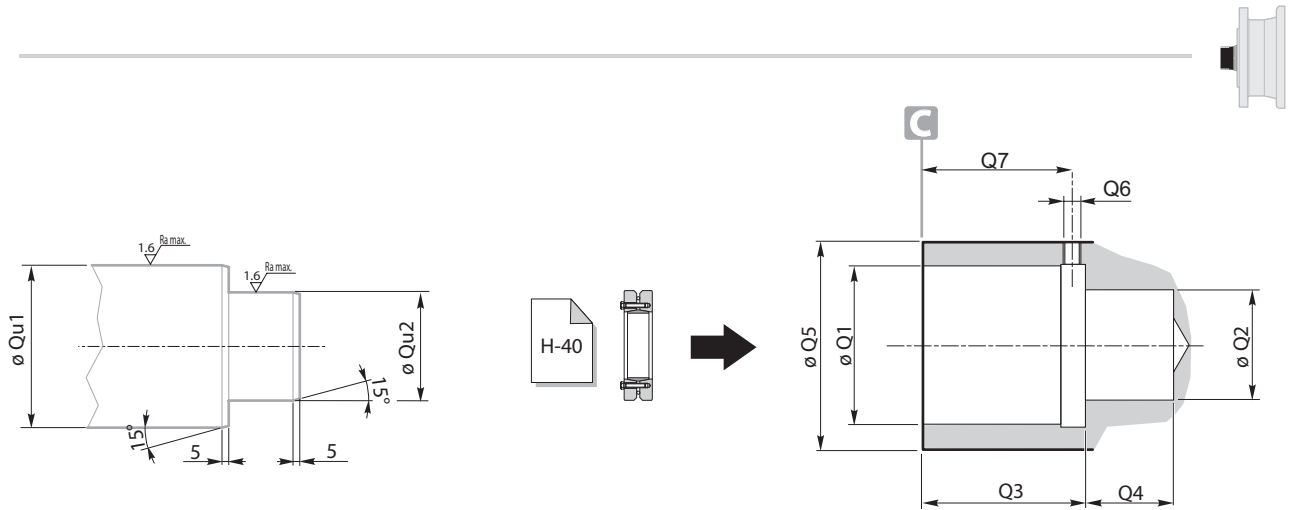

		RE - RA					
		1520	2000 2000L	2520	3000	3510	4800
<b>HQ</b>	<b>Q1</b>	120 H7	120 H7	130 H7	130 H7	145 H7	145 H7
	<b>Q2</b>	80 H7	80 H7	80 H7	80 H7	100 H7	100 H7
	<b>Q3</b>	85	85	100	100	146	146
	<b>Q4</b>	30	30	30	30	89.5	89.5
	<b>Q5</b>	165 f7	165 f7	175 f7	175 f7	185 f7	185 f7
	<b>Q6</b>	1/8"G	1/8"G	1/8"G	1/8"G	1/8"G	1/8"G
	<b>Q7</b>	97.5	97.5	99	99	136	136
	<b>Qu1</b>	120 g6	120 g6	130 g6	130 g6	145 g6	145 g6
	<b>Qu2</b>	80 f6	80 f6	80 f6	80 f6	100 f6	100 f6

		RE - RA							
		stages	1520	2000	2000L	2520	3000	3510	4800
<b>A1</b>			350	350	350	409	409	452	452
<b>FA1</b>	Q1		273	273	273	310	310	250	250
			—	—	—	—	—	—	260
<b>F2</b>			278 f7	278 f7	278 f7	340 f7	340 f7	390 f8	390 f8
<b>F3</b>			314	314	314	370	370	424	424
<b>F4</b>			10	10	10	17	17	15	15
<b>F5</b>			133	133	133	131	131	120	120
<b>F6</b>			$\varnothing 16.5$	$\varnothing 16.5$	$\varnothing 16.5$	$\varnothing 17$	$\varnothing 17$	$\varnothing 17$	$\varnothing 17$
			M16	M16	M16	M16	M16	M16	M16
<b>F6A</b>			$\varnothing 12$	$\varnothing 12$	$\varnothing 12$	$\varnothing 16$	$\varnothing 16$	—	—
<b>F7</b>			15°	15°	15°	12°	12°	20°	20°
<b>F7A</b>			30°	30°	30°	30°	30°	—	—
<b>F8</b>			15°	15°	15°	24°	24°	10°	10°
<b>FL</b>		1	107	107	107	98	98	85	85
		2	200	200	200	209	226	277	326
		3	264.5	258.5	264.5	276	311	362	419
		4	307.5	311	307.5	328.5	375.5	426.5	483.5
<b>FL7</b>		2	313	313	313	292	292	339	339
		3	322	322	322	351	368	419	532
<b>FL8</b>		2	345.5	380.5	345.5	398	433	484	541
		3	441	441	441	420	420	529	529
<b>FL8</b>		3	413	413	413	459	476	527	660
		4	420	472	420	489	524	575	632
<b>G2</b>			225 f7	225 f7	225 f7	245 f7	245 f7	—	—
<b>G4</b>			104.5	104.5	104.5	142	142	—	—
<b>G5</b>			27.5	27.5	27.5	29	29	—	—
<b>H</b>			15	15	15	29	29	—	—
<b>T3</b>		2	310	310	310	310	310	432	432
		3	171	171	171	227	227	227	310
		4	113.8	171	113.8	171	171	171	171
<b>T4</b>		2	293	293	293	293	293	295	295
		3	183	183	183	242	242	242	293
	4	184	183	184	183	183	183	183	



		RE - RA	
		4800	
<b>HQ1</b>	<b>Q1</b>	155 H7	
	<b>Q2</b>	100 H7	
	<b>Q3</b>	146	
	<b>Q4</b>	99.5	
	<b>Q5</b>	200 f7	
	<b>Q6</b>	1/8"G	
	<b>Q7</b>	136	
<b>Qu1</b>	155 g6		
<b>Qu2</b>	100 f6		



**1520 ÷ 2000L**

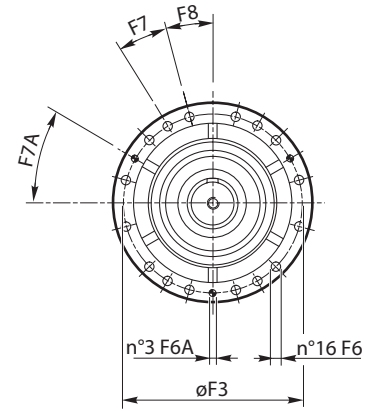
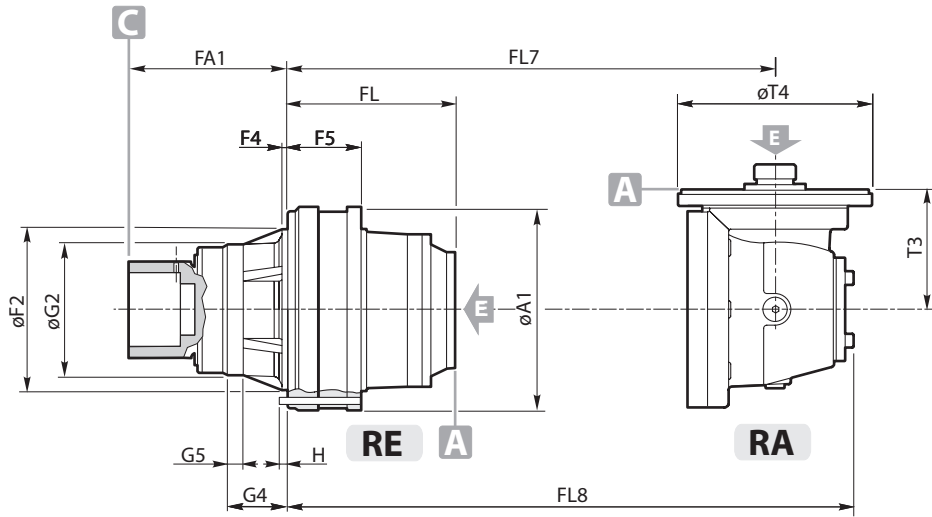

**2520 - 3000**

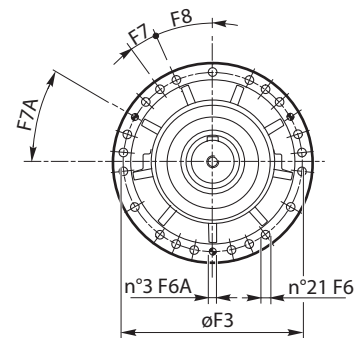
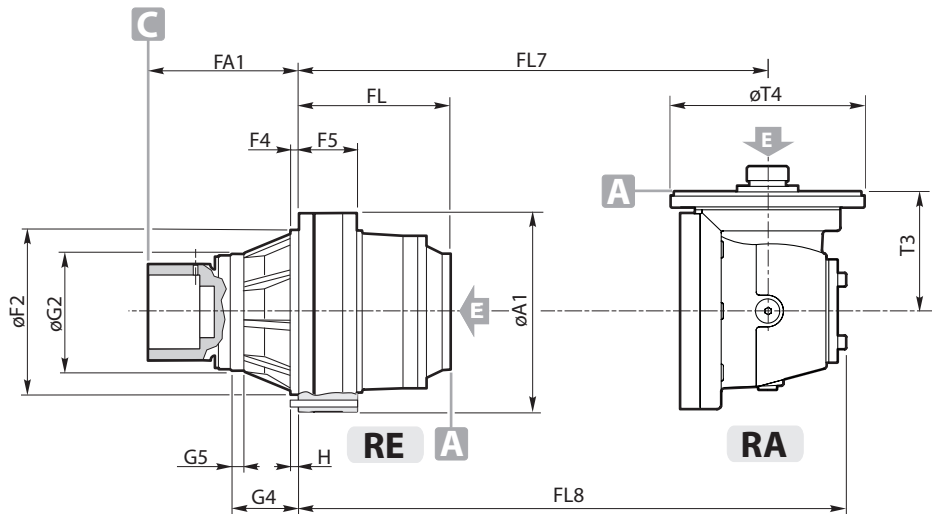

**3510 - 4800**

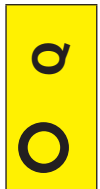
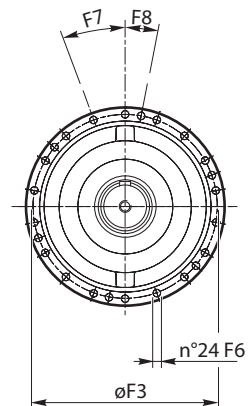
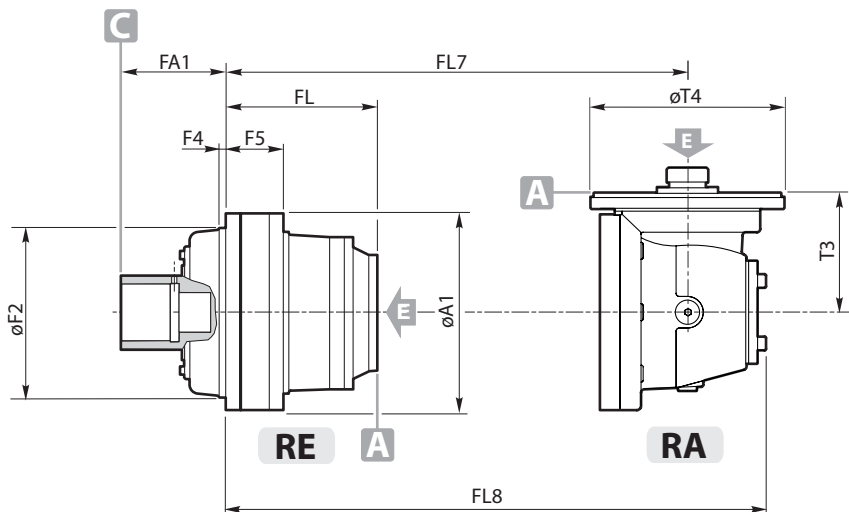

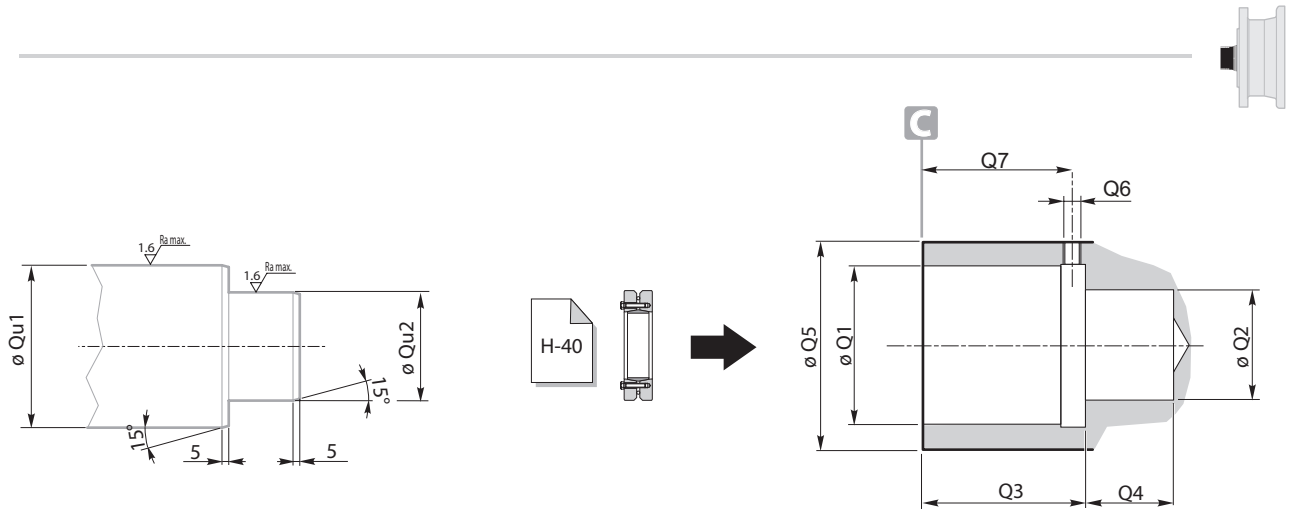

	RE - RA		GB - GBA		
	6000	8000	12010	16000	
	H6Q	HQ	HQ	HQ	
<b>HQ H6Q</b>	Q1	155 H7	155 H7	190 H7	190 H7
	Q2	85 F8	85 F8	90 H7	90 H7
	Q3	125	125	190	190
	Q4	70	70	40	40
	Q5	195 f7	195 f7	240 f7	240 f7
	Q6	1/8"G	1/8"G	1/8"G	1/8"G
	Q7	107	107	160	160
	Qu1	155 g6	155 g6	190 g6	190 g6
	Qu2	85 f6	85 f6	90 f6	90 f6

	stages	RE - RA		GB - GBA	
		6000	8000	12010	16000
		H6	H	H	H
A1		490	490	610	610
F2		410 h8	410 h8	515 h8	515 h8
F3		445	445	560	560
F4		15	15	20	20
F5		178.5	181.5	230	230
F6		$\varnothing 19$	$\varnothing 19$	$\varnothing 25$	$\varnothing 25$
		M18	M18	M24	M24
F7		7°30	7°30	15°	15°
F8		15°	15°	7°30'	7°30'
F9		7°30	7°30	7°30'	7°30'
FA1	Q	240	240	300	300
	Q1	298	298	330	330
FL	1	136.5	136.5	160.5	160.5
	2	305	390.5	410	427
	3	398	518.5	538	668
	4	456.5	603.5	623	761
	5	—	668	687.5	825.5
FL7	2	390.5	390.5	—	—
	3	511	584.5	604	681
	4	520	660.5	680	874
FL8	5	—	—	745	883
	2	580.5	580.5	—	—
	3	639	712.5	732	871
FL8	4	611	768.5	788	1002
	5	—	—	836	974
G2		—	—	—	—
G4		—	—	—	—
G5		—	—	—	—
T3	2	432	432	—	—
	3	310	310	310	432
	4	171	227	227	310
	5	—	—	171	171
T4	2	295	295	—	—
	3	293	293	293	295
	4	183	242	242	293
	5	—	—	183	183



	RE - RA		GB - GBA		
	6000	8000	12010	16000	
	H6Q1	HQ1	HQ1	HQ1	
<b>HQ1 H6Q1</b>	Q1	180 H7	180 H7	210 H7	210 H7
	Q2	110 H7	110 H7	110 H7	110 H7
	Q3	183	183	210	210
	Q4	70	70	50	50
	Q5	240 f7	240 f7	260 f7	260 f7
	Q6	1/8"G	1/8"G	1/8"G	1/8"G
	Q7	164	164	187	187
	Qu1	180 g6	180 g6	210 g6	210 g6
	Qu2	110 f6	110 f6	110 f6	110 f6



<b>H6Q</b>	<b>6000</b>
<b>HQ</b>	<b>8000</b>

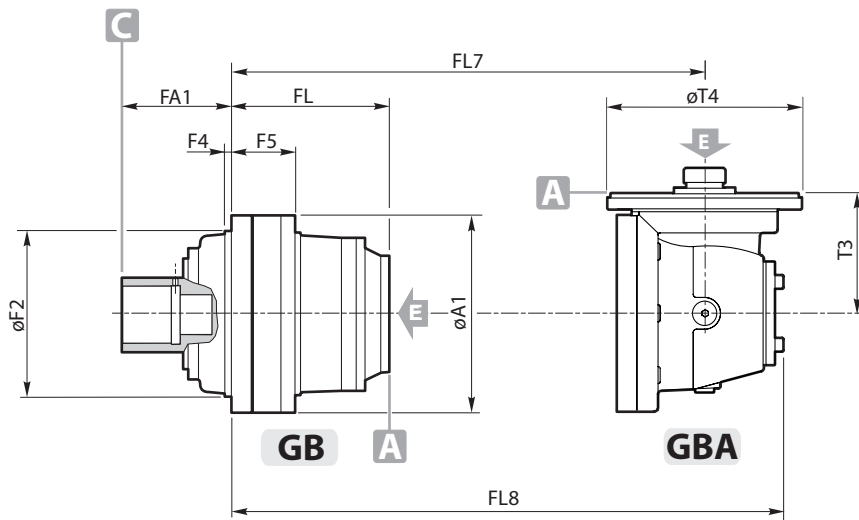
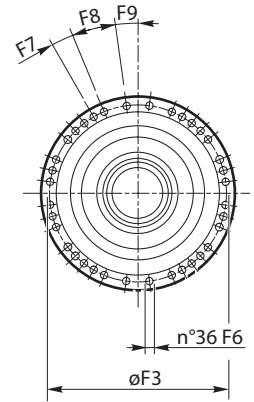
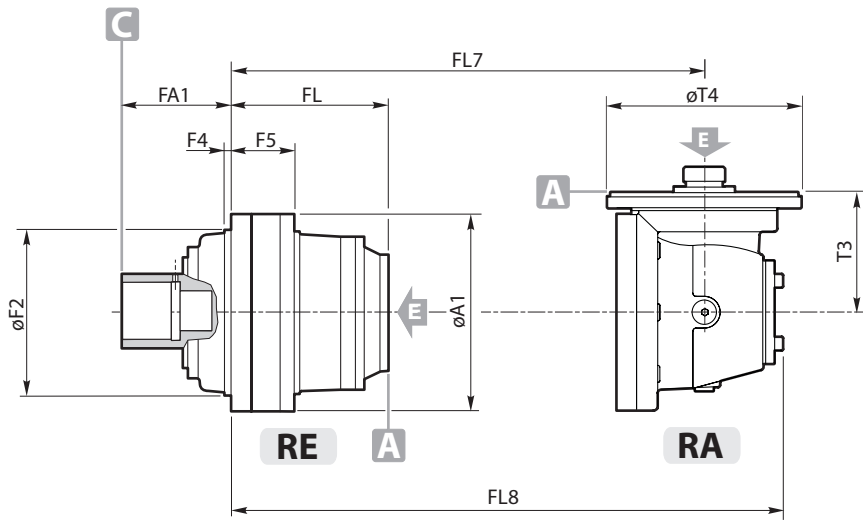

<b>HQ</b>	<b>12010 - 16000</b>
-----------	----------------------

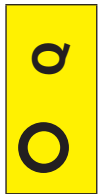
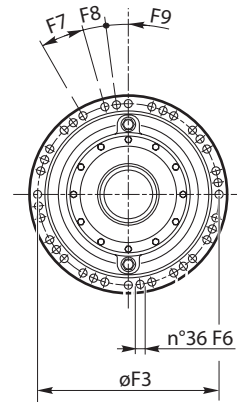

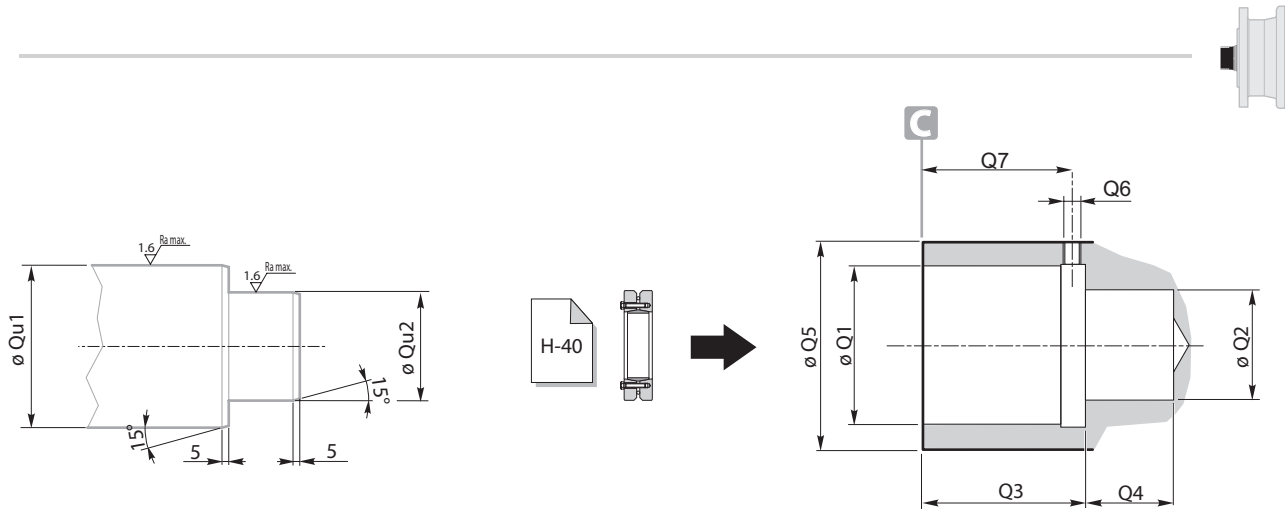

	RE - RA		GB - GBA		
	6000L	8000L	12010L	16000L	
	H6Q	HQ	HQ	HQ	
<b>HQ H6Q</b>	Q1	155 H7	155 H7	190 H7	190 H7
	Q2	85 F8	85 F8	90 H7	90 H7
	Q3	125	125	190	190
	Q4	70	70	40	40
	Q5	195 f7	195 f7	240 f7	240 f7
	Q6	1/8"G	1/8"G	1/8"G	1/8"G
	Q7	107	107	160	160
	Qu1	155 g6	155 g6	190 g6	190 g6
	Qu2	85 f6	85 f6	90 f6	90 f6

	stages	RE - RA		GB - GBA	
		6000L	8000L	12010L	16000L
		H6	H	H	H
A1		490	490	610	610
F2		410 h8	410 h8	515 h8	515 h8
F3		445	445	560	560
F4		15	15	20	20
F5		178.5	181.5	230	230
F6		$\varnothing 19$	$\varnothing 19$	$\varnothing 25$	$\varnothing 25$
		M18	M18	M24	M24
F7		7°30'	7°30'	15°	15°
F8		15°	15°	7°30'	7°30'
F9		7°30'	7°30'	7°30'	7°30'
FA1	Q	240	240	300	300
	Q1	298	298	330	330
FL	1	136.5	136.5	160.5	160.5
	2	305	390.5	410	427
	3	398	501.5	521	619
	4	462.5	568.5	588	704
	5	—	621	640.5	768.5
FL7	2	390.5	390.5	—	—
	3	511	584.5	604	681
	4	520	643.5	663	761
	5	—	—	710	826
	FL8	2	580.5	580.5	—
3		639	712.5	732	871
4		611	751.5	771	869
5		—	—	801	917
G2			432	432	—
G4		310	310	310	432
G5		171	227	227	310
T3	2	—	—	171	171
	3	295	295	—	—
	4	293	293	293	295
	5	183	242	242	293
T4	2	—	—	183	183
	3	293	293	293	295
	4	183	242	242	293
	5	—	—	183	183



	RE - RA		GB - GBA		
	6000L	8000L	12010L	16000L	
	H6Q1	HQ1	HQ1	HQ1	
<b>HQ1 H6Q1</b>	Q1	180 H7	180 H7	210 H7	210 H7
	Q2	110 H7	110 H7	110 H7	110 H7
	Q3	183	183	210	210
	Q4	70	70	50	50
	Q5	240 f7	240 f7	260 f7	260 f7
	Q6	1/8"G	1/8"G	1/8"G	1/8"G
	Q7	164	164	187	187
	Qu1	180 g6	180 g6	210 g6	210 g6
	Qu2	110 f6	110 f6	110 f6	110 f6



<b>H6Q</b>	<b>6000L</b>
<b>HQ</b>	<b>8000L</b>

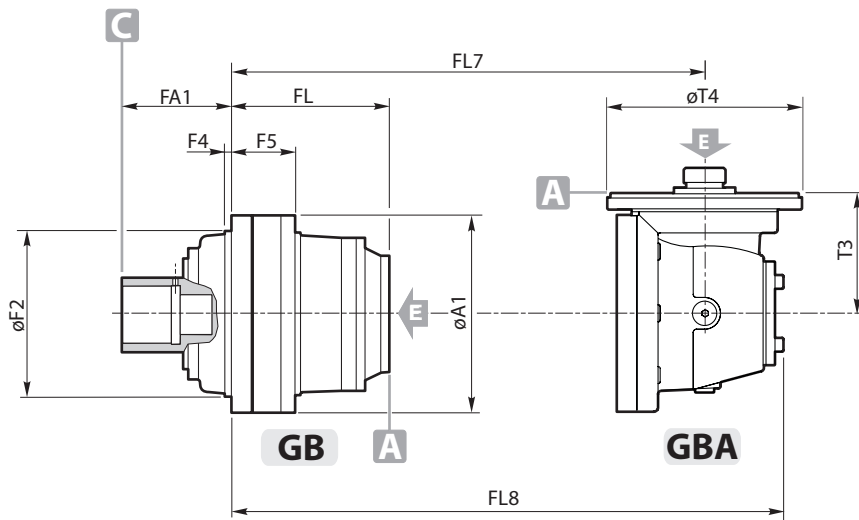
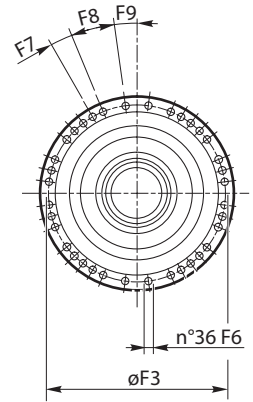
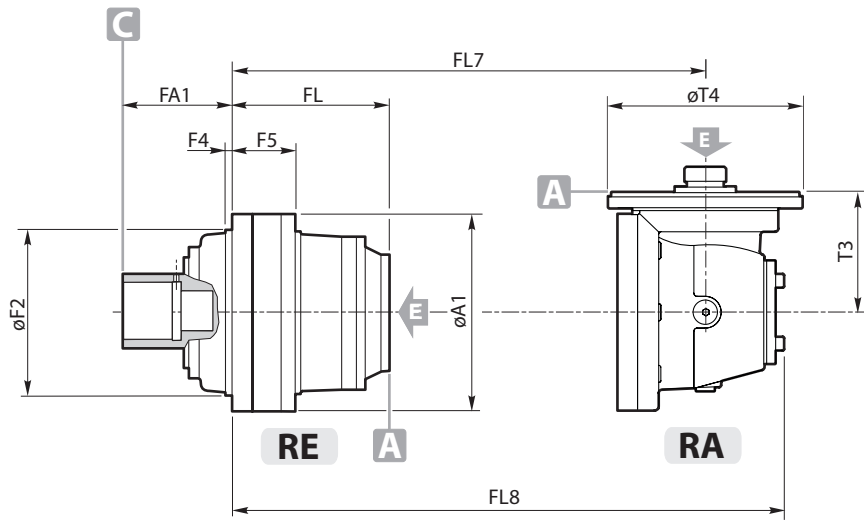

<b>HQ</b>	<b>12010L - 16000L</b>
-----------	------------------------

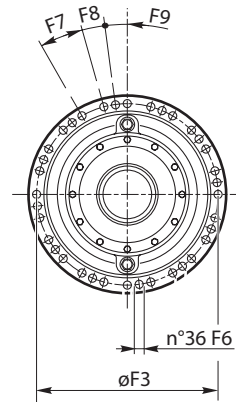

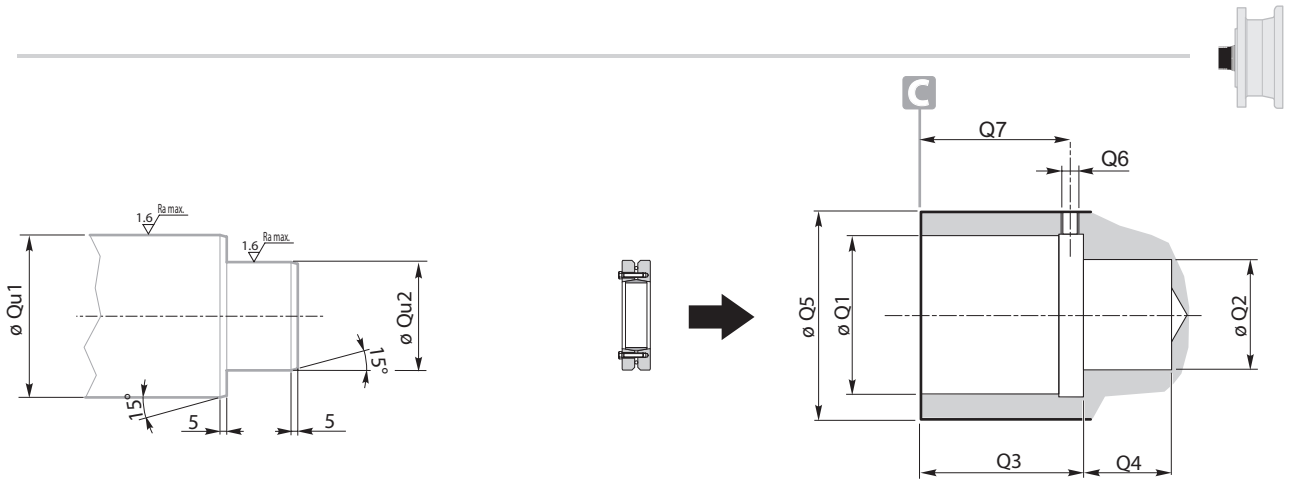

		GB - GBA							
		21000	26000	31000	40000	45000	53000	61000	85000
<b>HQ</b>	<b>Q1</b>	230 H7	230 H7	295 H7	295 H7	300 H7	320 H7	320 H7	380 H7
	<b>Q2</b>	120 H7	120 H7	210 H7	210 H7	210 H7	190 H7	190 H7	260 H7
	<b>Q3</b>	230	230	300	300	300	335	335	335
	<b>Q4</b>	101	101	155	155	155	175	175	170
	<b>Q5</b>	280 f7	280 f7	360 f7	360 f7	380 f7	390 f7	390 f7	460 f7
	<b>Q6</b>	1/8"G	1/8"G	1/8"G	1/8"G	1/8"G	1/4"G	1/4"G	1/4"G
	<b>Q7</b>	225	225	265	265	265	305	305	323
	<b>Qu1</b>	230 g6	230 g6	295 g6	295 g6	300 g6	320 h6	320 h6	380 g6
	<b>Qu2</b>	120 f6	120 f6	210 f6	210 f6	210 f6	190 f6	190 f6	260 f6

		GB - GBA							
	stages	21000	26000	31000	40000	45000	53000	61000	85000
<b>A1</b>		710	710	870	870	870	1090	1090	1090
<b>F2</b>		600 h8	600 h8	760 h8	760 h8	760 h8	930 h8	930 h8	930 h8
<b>F3</b>		660	660	810	810	810	1020	1020	1020
<b>F4</b>		23.5	23.5	35	35	35	50	50	50
<b>F5</b>		196	216	250	290	290	305	305	353
<b>F6</b>		Ø28	Ø28	Ø32	Ø32	Ø32	Ø39	Ø39	Ø39
		M... - 10.9							
		M27	M27	M30	M30	M30	M36	M36	M36
<b>F7</b>		10°	10°	10°	10°	10°	10°	10°	10°
<b>FA1</b>		440	440	490	490	490	550	550	550
<b>FL</b>	1	138	158	180	220	220	225	225	273
	2	443	463	588.5	628.5	628.5	700	700	768
	3	611.5	717	838	878	895	1005	1005	1073
	4	704.5	845	966	1006	1136	1173.5	1173.5	1327
	5	763	930	1051	1091	1229	1266.5	1266.5	1455
<b>FL7</b>	3	697	717	—	—	—	—	—	—
	4	817.5	911	1032	1072	1149	1259	1259	1327
	5	826.5	987	1108	1148	1342	1379.5	1379.5	1521
	6	—	—	—	—	—	—	1388.5	1597
<b>FL8</b>	3	887	907	—	—	—	—	—	—
	4	945.5	1039	1160	1200	1339	1449	1449	1517
	5	917.5	1095	1216	1256	1470	1507.5	1507.5	1649
	6	—	—	—	—	—	—	1479.5	1705
<b>T3</b>	3	432	432	—	—	—	—	—	—
	4	310	310	310	310	432	432	432	432
	5	171	227	227	227	310	310	310	310
	6	—	—	—	—	—	—	171	171
<b>T4</b>	3	295	295	—	—	—	—	—	—
	4	293	293	293	293	295	295	295	295
	5	183	242	242	242	293	293	293	293
	6	—	—	—	—	—	—	183	183



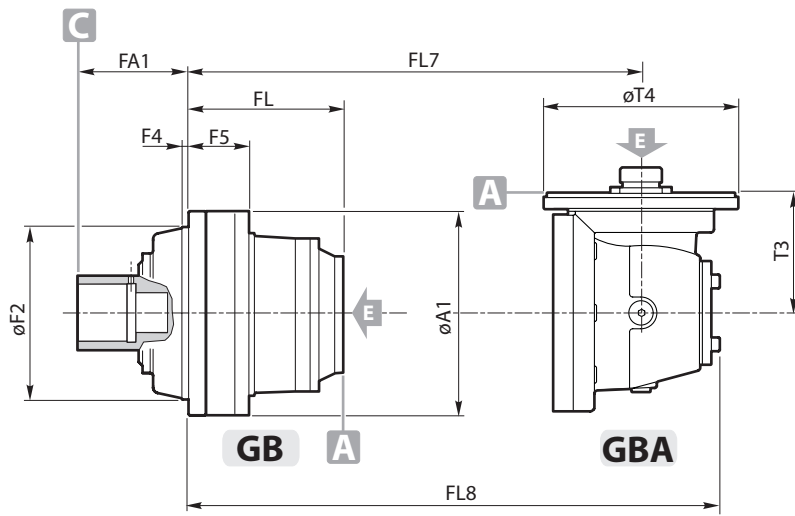

**21000 - 26000**

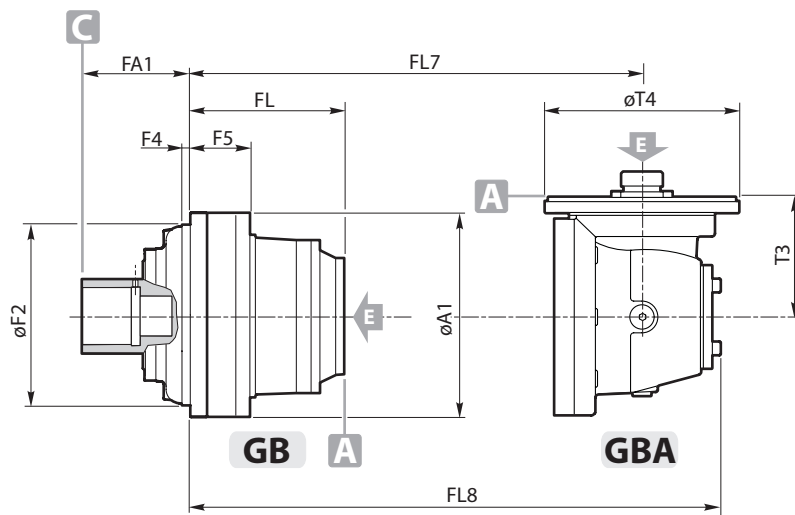
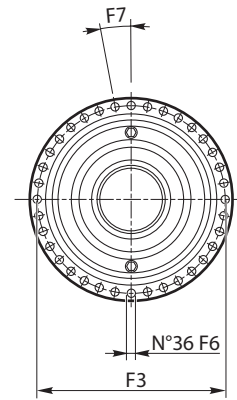

**31000 ÷ 45000**

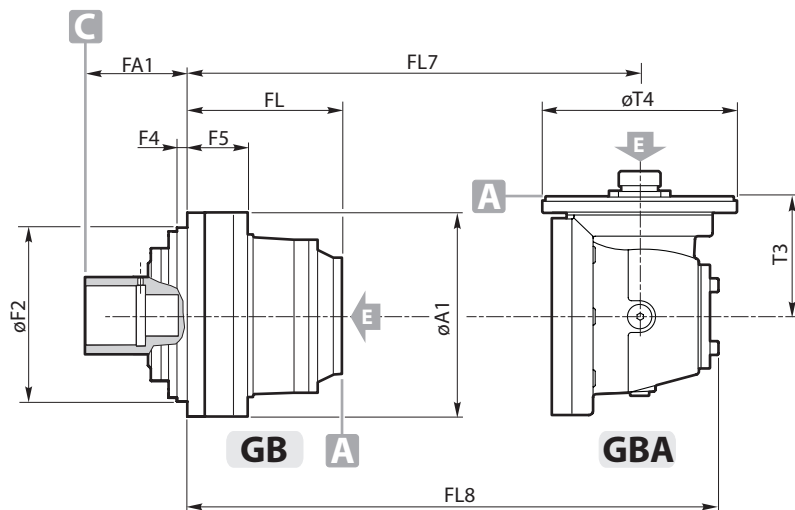
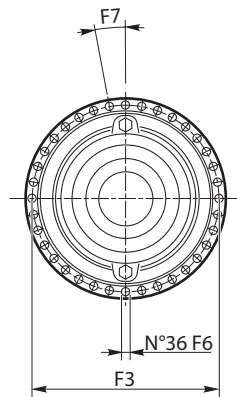

**53000 ÷ 85000**

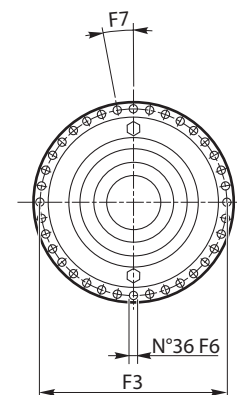

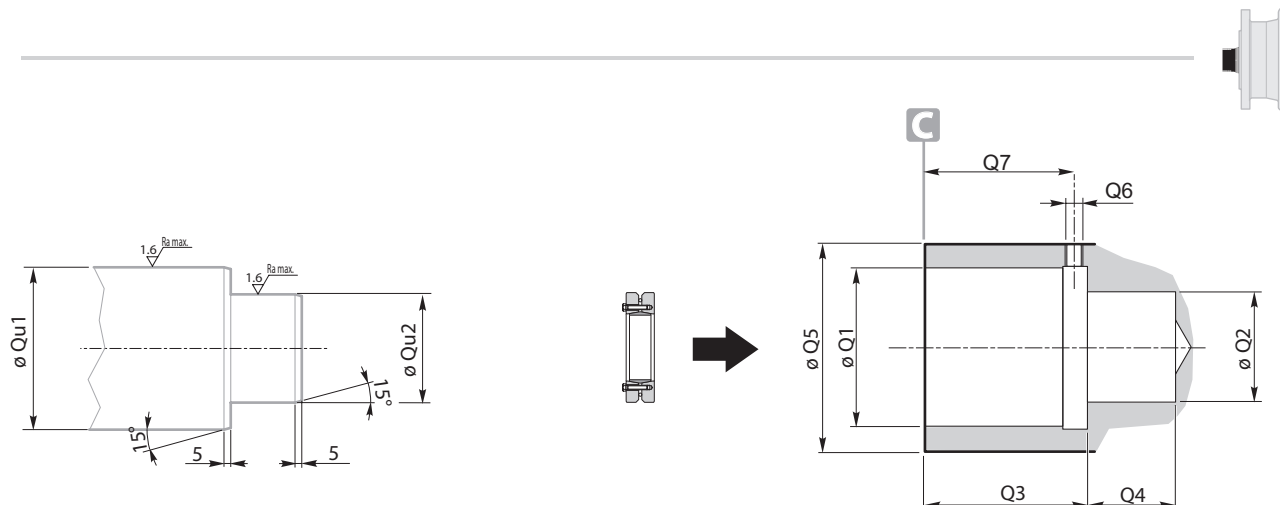

		GB - GBA				
		110000	130000	150000	205000	235000
HQ	Q1	450 H7	450 H7	450 H7	600 H7	600 H7
	Q2	320 H7	320 H7	320 H7	590 H7	590 H7
	Q3	450	450	450	277	277
	Q4	150	150	150	282	282
	Q5	560 f7	560 f7	560 f7	700 f7	700 f7
	Q6	1/4"G	1/4"G	1/4"G	—	—
	Q7	420	420	420	—	—
	Qu1	450 h6	450 h6	450 h6	600 g6	600 g6
	Qu2	320 f6	320 f6	320 f6	590 g6	590 g6



		GB - GBA				
		110000	130000	150000	205000	235000
A1	stages	1320	1320	1320	1630	1630
F0		1538	1538	1538	1880	1880
F2		1150 h9	1150 h9	1150 h9	1440 h8	1440 h8
F3		1450	1450	1450	1780	1780
F4		80	80	80	80	80
F5		110	110	110	110	110
F6		Ø44 (x40)	Ø44 (x40)	Ø44 (x40)	Ø44 (x48)	Ø44 (x48)
		M42	M42	M42	M42	M42
F7		9°	9°	9°	7°30'	7°30'
FA1		722.5	722.5	722.5	675	675
FL	1	315	315	315	303	303
	2	966.5	966.5	966.5	1016	1016
	3	1375	1375	1375	1511	1590.5
	4	1624.5	1641.5	1721.5	1852	1986.5
	5	1752.5	1882.5	1890	2101.5	2236
FL7	5	1818.5	1895.5	—	—	—
	6	1894.5	2088.5	—	—	—
FL8	5	1946.5	2085.5	—	—	—
	6	2002.5	2216.5	—	—	—
T3	5	310	432	—	—	—
	6	227	310	—	—	—
T4	5	293	295	—	—	—
	6	242	293	—	—	—

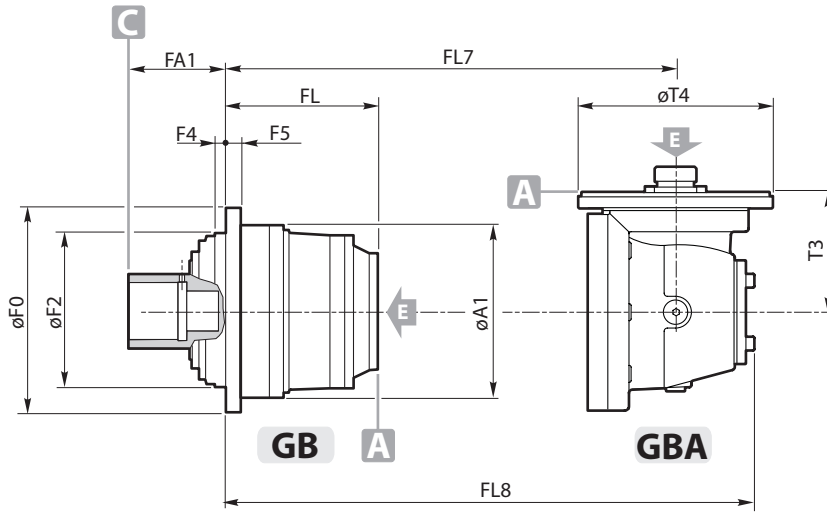

**110000 ÷ 235000**

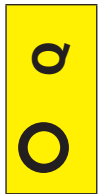
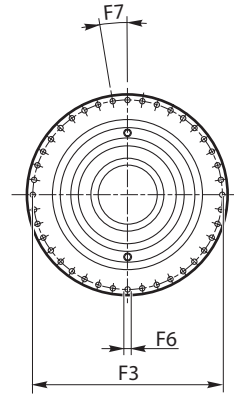

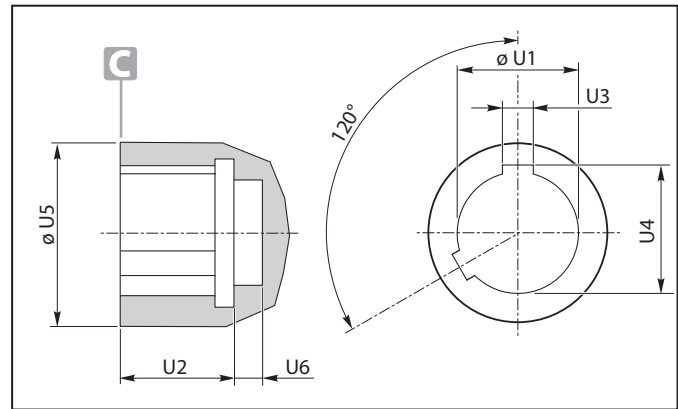
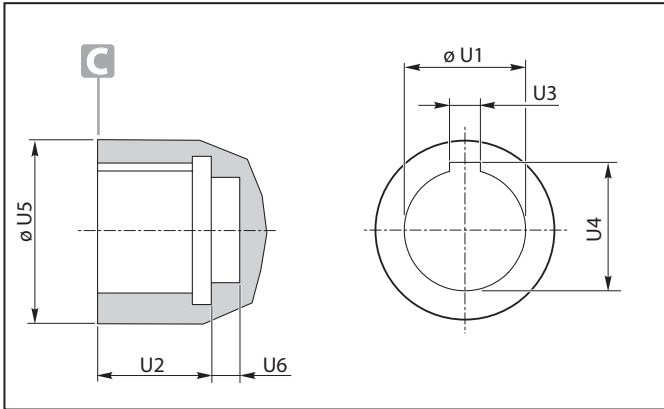

		RE - RA				
		110	210	310	510	610
TU	U1	40 H7	40 H7	—	—	—
	U2	49	49	—	—	—
	U3	12	12	—	—	—
	U4	43.3	43.3	—	—	—
	U5	60	60	—	—	—
	U6	15	15	—	—	—

		RE - RA		
		310	510	610
NU	U1	60 H7	60 H7	60 H7
	U2	60	60	60
	U3	18	18	18
	U4	64.5	64.5	64.5
	U5	85	85	85
	U6	15	15	15

NU2	U1	—	—	70 G6	70 G6	70 G6
	U2	—	—	75	75	75
	U3	—	—	20	20	20
	U4	—	—	75	75	75
	U5	—	—	99.5	99.5	99.5
	U6	—	—	20	20	20

		RE - RA									
		110		210		310		510		610	
		TU	TU	NU	NU2	NU	NU2	NU	NU2	NU	NU2
A1		186	186	244	244	244	244	244	244	244	244
F0		219	219	222	222	222	222	222	222	222	222
F2		155 h7	155 h7	168 f7	168 f7	168 f7	168 f7	168 f7	168 f7	168 f7	168 f7
F3		194	194	195	190	195	190	195	190	195	190
F4		7	7	20.5	13.5	20.5	13.5	20.5	13.5	20.5	13.5
F5		15	15	16	16	16	16	16	16	16	16
F6		Ø11	Ø11	Ø12.5	Ø14.5	Ø12.5	Ø14.5	Ø12.5	Ø14.5	Ø12.5	Ø14.5
		M10	M10	M12	M14	M10	M14	M10	M14	M10	M14
F7		36°	36°	36°	45°	36°	45°	36°	45°	36°	45°
F8		—	—	—	22°30'	—	22°30'	—	22°30'	—	22°30'
FA1		25	25	52	130	52	130	52	130	52	130
FL	1	102	114	133	133	151	151	151	151	151	151
	2	145	157	185.5	185.5	215.5	215.5	209.5	209.5	209.5	209.5
	3	188	200	228.5	228.5	258.5	258.5	262	262	262	262
	4	231	243	271.5	271.5	301.5	301.5	305	305	305	305
FL7	2	183	195	255	255	273	273	273	273	273	273
	3	226	238	266.5	266.5	296.5	296.5	331.5	331.5	331.5	331.5
FL8	2	257.5	269.5	346	346	364	364	364	364	364	364
	3	300.5	312.5	341	341	371	371	422.5	422.5	422.5	422.5
T3	2	113.8	113.8	171.5	171.5	171.5	171.5	171.5	171.5	171.5	171.5
	3	113.8	113.8	113.8	113.8	113.8	113.8	171.5	171.5	171.5	171.5
	4	113.8	113.8	113.8	113.8	113.8	113.8	113.8	113.8	113.8	113.8
T4	2	184	184	183	183	183	183	183	183	183	183
	3	184	184	184	184	184	184	183	183	183	183
	4	184	184	184	184	184	184	184	184	184	184

O U

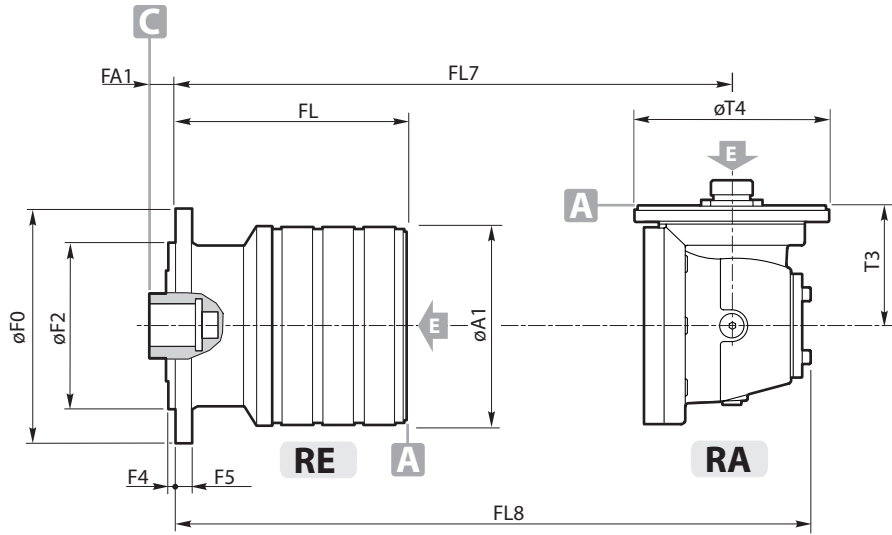

**TU 110 - 210**

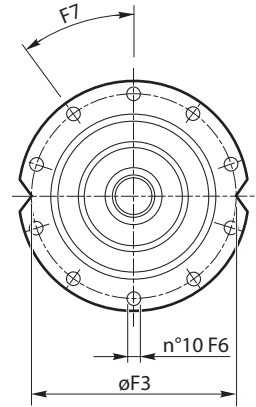

**NU 310 - 510 - 610**

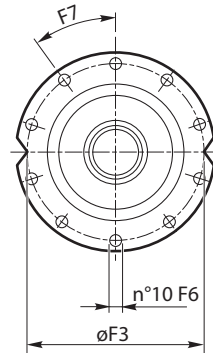
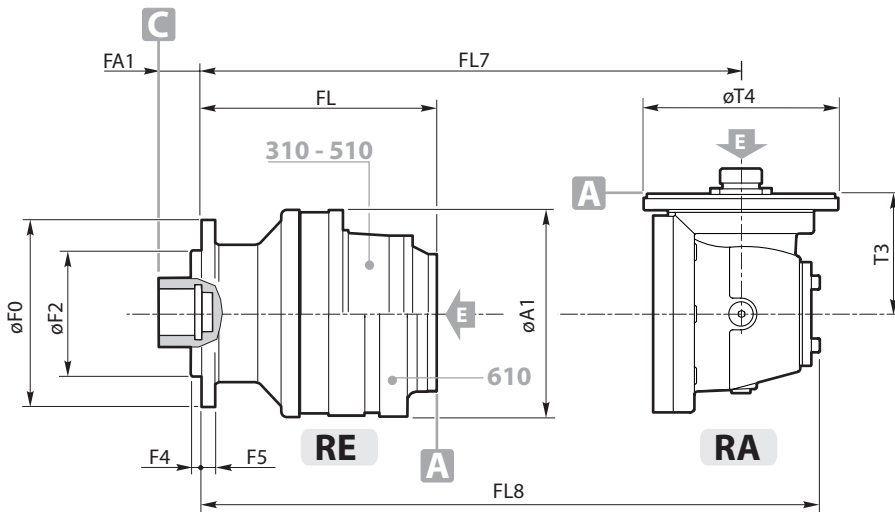

**NU2 310 - 510 - 610**

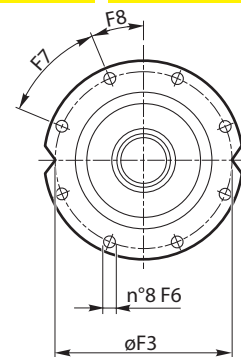

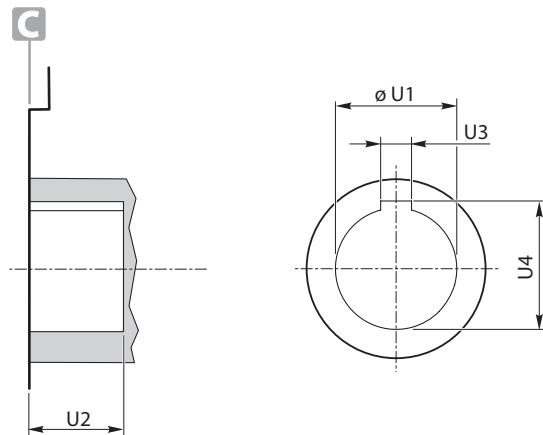

		RE - RA	
		110	210
FC	U1	40 H7	40 H7
	U2	38	38
	U3	12	12
	U4	43.3	43.3

		RE - RA	
	stages	110	210
A1		186	186
F2		110 h7	110 h7
F3		165	165
F4		5	5
F6		Ø10.5	Ø10.5
F7		45°	45°
F8		22.5°	22.5°
FA1		5	5
FL	1	59	71
	2	102	114
	3	145	157
	4	188	200
FL7	2	140	152
	3	183	195
	4	226	238
FL8	2	214.5	226.5
	3	257.5	269.5
	4	300.5	312.5
T3	2	113.8	113.8
	3	113.8	113.8
	4	113.8	113.8
T4	2	184	184
	3	184	184
	4	184	184

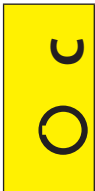

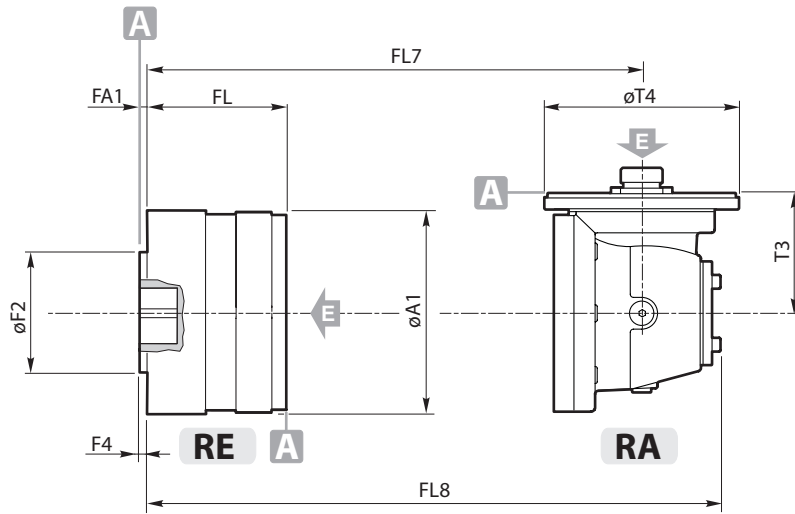

**110 - 210**

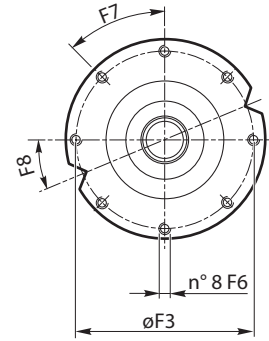



**I****ENTRATE, ACCESSORI, POSIZIONI DI MONTAGGIO, PESI E VOLUMI**

Le tavole degli accessori comprendono flange di adattamento e freni. In questa sezione sono inoltre rappresentate le varie posizioni di lavoro dei riduttori e le relative posizioni dei tappi di carico, scarico e livello olio e quelli di sfiato aria.

**I pesi dei riduttori ed i volumi di olio sono puramente indicativi in quanto variano al variare del rapporto e degli accessori installati.**

Qualora si desideri un'informazione precisa si contatti la rete vendita Dinamic Oil comunicando il codice di ordinazione in modo completo.

**UK****INPUTS, ACCESSORIES, WEIGHTS, VOLUMES AND MOUNTING POSITIONS**

The accessory tables include motor, adapter flanges and brakes. This section also shows the gearboxes working positions options; the location for oil filling, oil level and oil drain ports, as well as breather plugs.

**Weights and oil volumes are purely indicative because they vary with respect to the installed accessories and the reduction ratio.**

When a precise figure is needed please contact Dinamic Oil sales network specifying the complete ordering code.



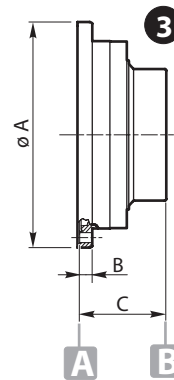
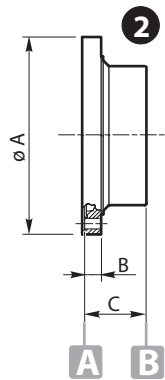
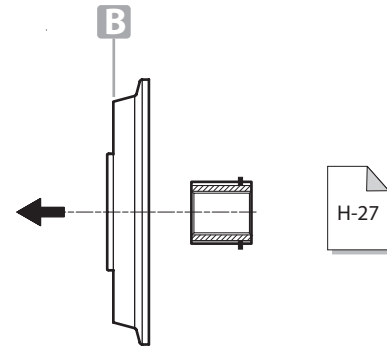
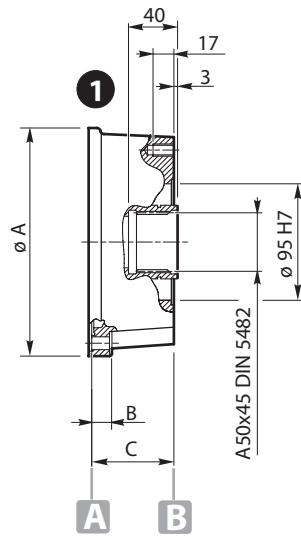
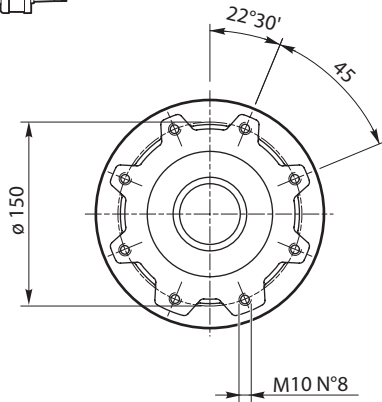
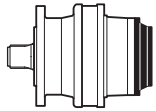

### 1

$\varnothing A$	B	C	Code
186	14.5	67	K0700A1
RE 111 - 112 - 113 - 114			
RE 211 - 212 - 213 - 214			
RE 241 - 242 - 243 - 244			
RE 312 - 313 - 314			
RE 512 - 513 - 514			
RE 613 - 614			
RE 813 - 814			
RE 1023 - 1024			
RE 1523 - 1524			
RE 2004			
RE 2524			
RE 3004			
RE 3514-4804			
RE 6004L			
RE 8005 - 8005L			
GB 12015 - 12015L			
GB 16005 - 16005L			
CC30-CC120			

### 2

$\varnothing A$	B	C	Code
244	20.5	76.5	K0700D2
RE 311-511			
RE 611 - 612			
RE 812-1022			
RE 1522-2003			
RE 2523-3003			
RE 3513-4803			
RE 6003 - 6003L			
RE 6004 - 6004L			
RE 8004 - 8004L			
GB 12014 - 12014L			
GB 16004 - 16004L			
GB 21004 - 21005			
GB 26005-31005			
GB 40005-45005			
GB 53005			
CC350			

### 3

$\varnothing A$	B	C	Code
295	16	121	K0700D2
RE 811			
RE 1021			
RE 2522			
RE 3002			
RE 3512			
RE 8003 - 8003L			
GB 12013 - 12013L			
GB 16003L			
GB 26004			
GB 31004			
GB 40004			
GB 85005			
GB 110005			
CC1000			
CC600			

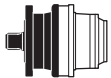
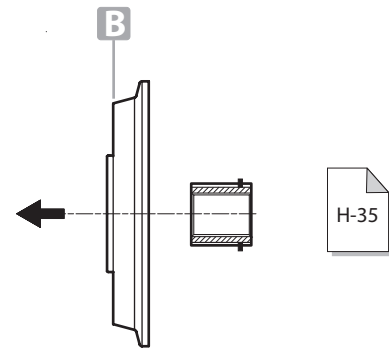
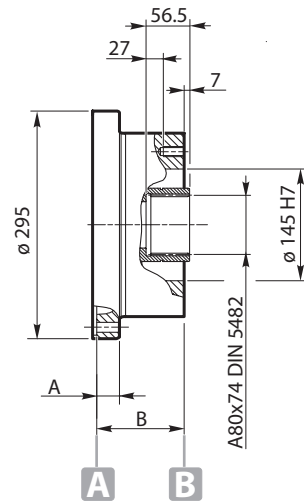
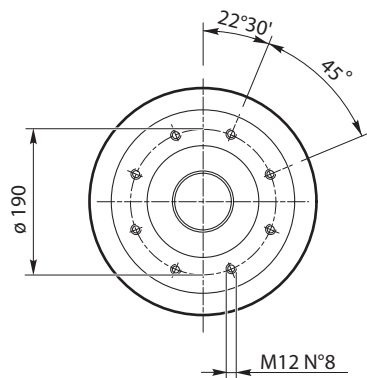

	A	B	Code
RE 811			
RE 1021			
RE 2522			
RE 3002			
RE 3512			
RE 8003 - 8003L			
GB 12013 - 12013L	30	114	K0700D3
GB 16003L			
GB 26004			
GB 31004			
GB 40004			
GB 85005			
GB 110005			
CC600	50	134	
CC1000	61	145	

# CC30 - CC120

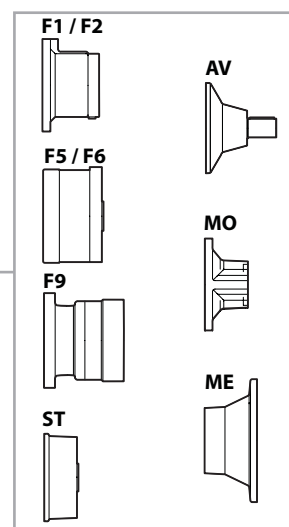
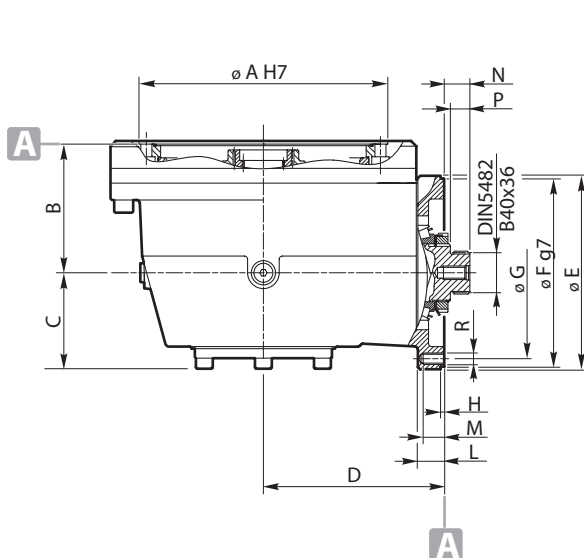
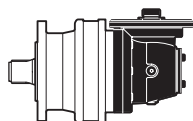

	$\varnothing A$	B	C	D	$\varnothing E$	$\varnothing F$	$\varnothing G$	H	L	N	P	R	
<b>CC30</b> 110/210/240	RA 112-113-114												
	RA 212-213-214												
	RA 242-243-244												
	RA 313-314												
	RA 513-514	178	84	71.5	113.8	184	178	165	4	15.7	23.75	18.25	N°8-M10 AT 45°
	RA 814												
	RA 1024												
	RA 1524												
	RA 2004L												

	$\varnothing A$	B	C	D	$\varnothing E$	$\varnothing F$	$\varnothing G$	H	L	M	P	R	
<b>CC120</b> 310/510/610	RA 312												
	RA 512-612												
	RA 613-813												
	RA 1023												
	RA 1523												
	RA 2003-2003L												
	RA 2524												
	RA 3004	236	122	91	171.5	183	178	165	3.5	25	24.25	18.5	N°8-M10 AT 45°
	RA 3514												
	RA 4804												
	RA 6004-6004L												
	GBA 12015-12015L												
	GBA 16005-16005L												
	GBA 21005												

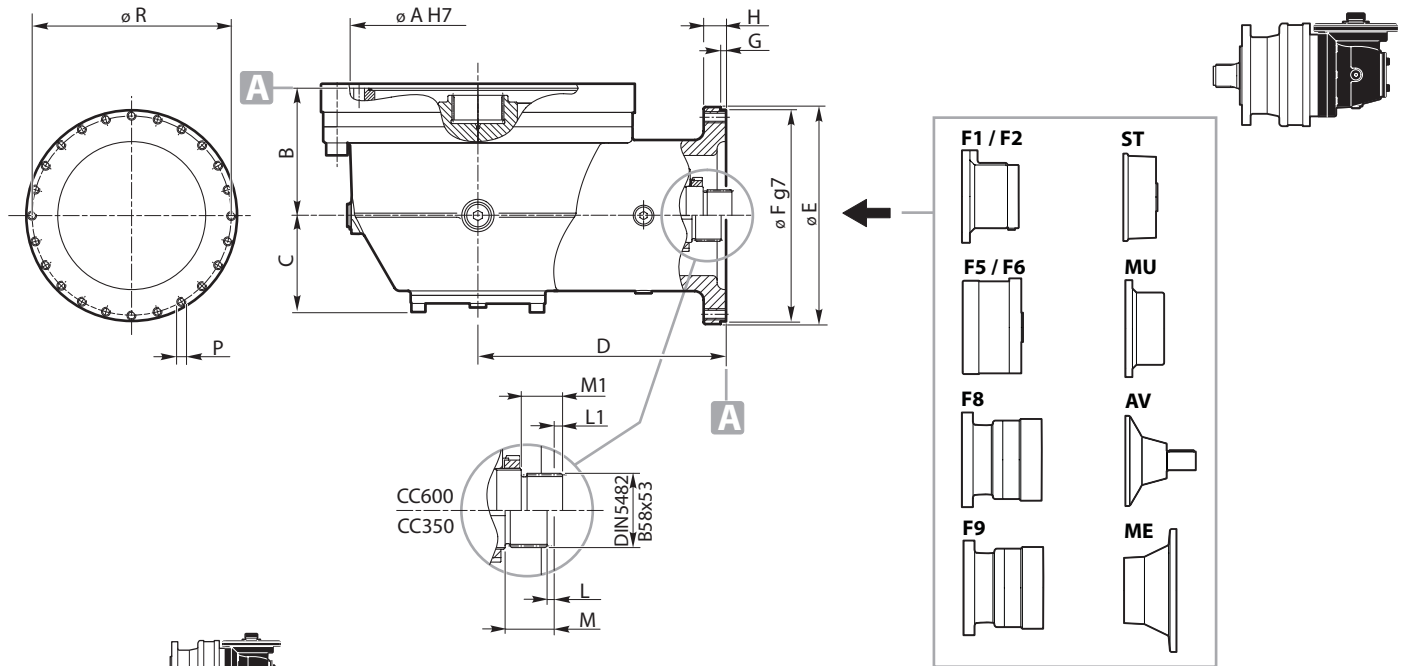

	$\phi A$	B	C	D	$\phi E$	$\phi F$	G	H	L	M	P	R
<b>CC350</b> 810/1020 RA 812 RA 1022 RA 2523 RA 3023 RA 3523 RA 8004-8004L GBA 12014-12014L GB 16004L GBA 26005 GBA 31005 GBA 40005	285	142	108	276.75	242	236	6	25	5,5	38	N°24-M10 AT 15°	222

	$\phi A$	B	C	D	$\phi E$	$\phi F$	G	H	L1	M1	P	R
<b>CC600</b> 810/1020 RA 812 RA 1022 RA 2523 RA 3023 RA 3523 RA 8004 GBA 12014 GBA 16004 GBA 26005 GBA 31005 GBA 40005	285	198	128	310	293	285	8	27	6,5	25,5	N°12-M10 AT 30°	265

	$\phi A$	B	C	D	$\phi E$	$\phi F$	G	H	L1	M1	P	R
<b>CC600</b> 1520/2000 RA 1522 RA 2002 RA 4803 RA 6003-6003L GBA 16014 GBA 21004 GBA 45005 GBA 53005 GBA 61005	340	206	128	310	293	285	8	27	6,5	25,5	N°12-M10 AT 30°	265

	$\phi A$	B	C	D	$\phi E$	$\phi F$	G	H	L1	M1	P	R
<b>CC600</b> 2520/3000 RA 2522 RA 3002 RA 8003-8003L GBA 12013-12013L GBA 26004 GBA 31004 GBA 40004 GBA 85005 GBA 110005	395	194	128	310	293	285	8	27	6,5	25,5	N°12-M10 AT 30°	265

# CC1000

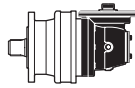
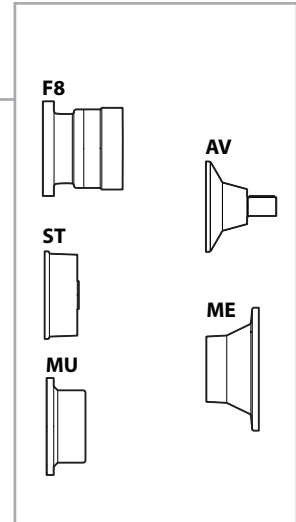
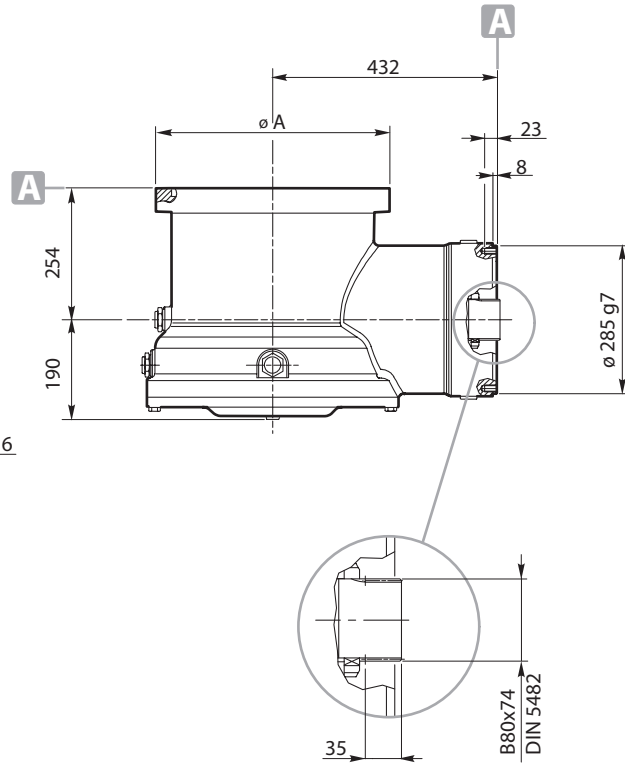
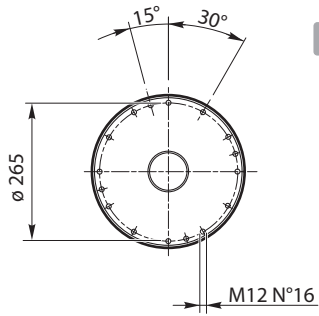
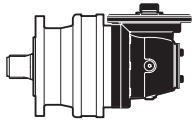

## CC1000

	$\phi A$
RA 3512-4802	452
RA 6002-8002	490
GBA 16003-16003L	452
GBA 21003-26003	490
GBA 45004	452
GBA 53004-61004	490
GBA 85004	490
GBA 130005	452

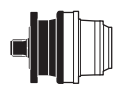
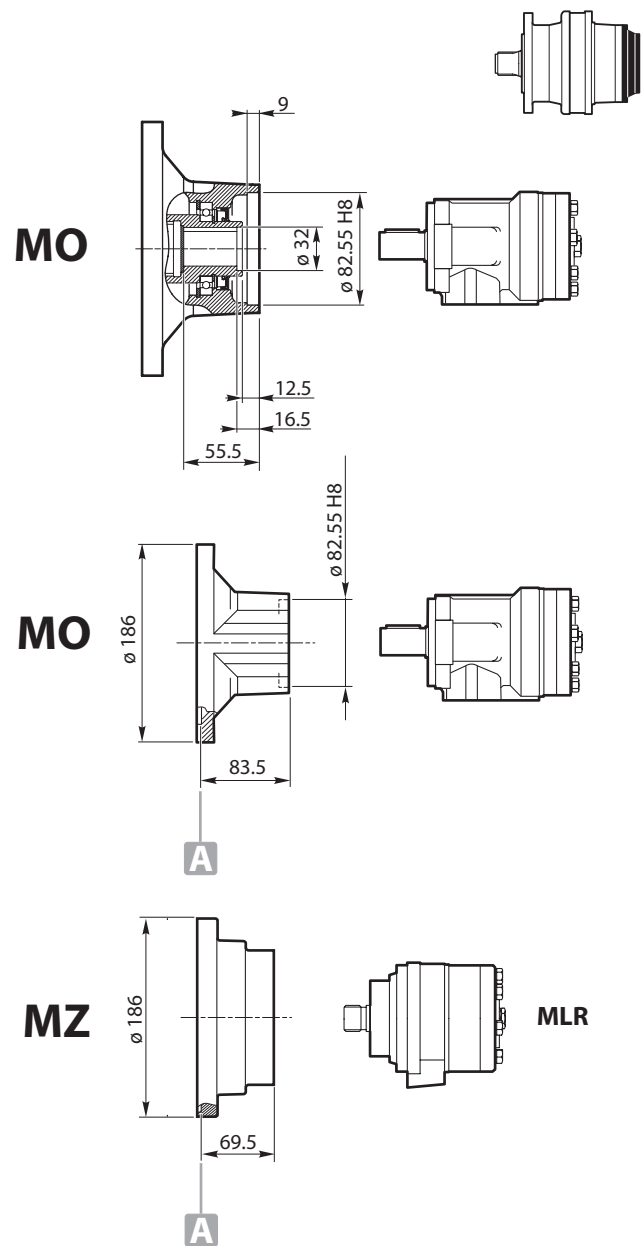
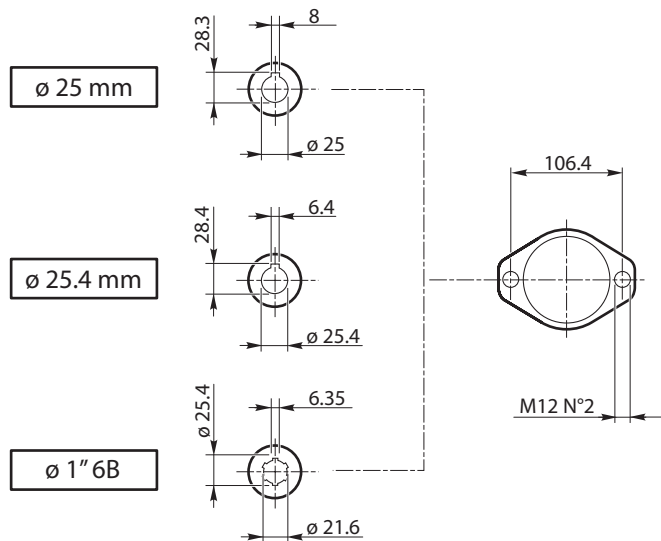

	Type	Code
RE 111 - 112 - 113 - 114		
RE 211 - 212 - 213 - 214		
RE 241 - 242 - 243 - 244		
RE 312 - 313 - 314		
RE 512 - 513 - 514		
RE 613 - 614		
RE 813 - 814		
RE 1023 - 1024	MO 25	K0700AA
RE 1523 - 1524	MO 25.4	K0700AB
RE 2004	MO 1"6B	K0700AC
RE 2524	MZ	—
RE 3004		
RE 3514-4804		
RE 6004L		
RE 8005 - 8005L		
GB 12015 - 12015L		
GB 16005 - 16005L		
CC30-CC120		

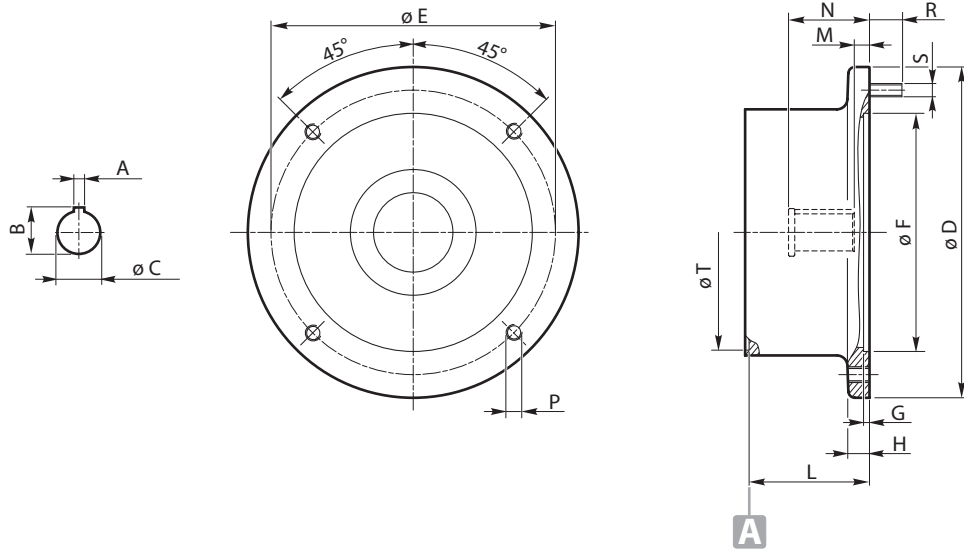
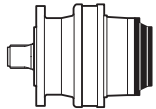

	Input type	Shaft			Flange											
		A	B	C	D	E	F	G	H	L	M	N	P	R	S	T
RE 111 - 112 - 113 - 114 RE 211 - 212 - 213 - 214 RE 241 - 242 - 243 - 244 RE 312 - 313 - 314 RE 512 - 513 - 514 RE 613 - 614 RE 813 - 814 RE 1023 - 1024 RE 1523 - 1524 RE 2004 - RE 2004L RE 2524 RE 3004 RE 3514 - 4804 RE 6004L RE 8005 - 8005L GB 12015 - 12015L GB 16005 - 16005L CC30-CC120	<b>ME 80</b>	6	21.8	19	200	165	130	4	16	82.5	6.5	44.5	—	25	N°4-M10	178
	<b>ME 90</b>	8	27.3	24	200	165	130	4	16	82.5	11.5	52	—	25	N°4-M10	
	<b>ME 100/112</b>	8	31.3	28	250	215	180	4.5	16	91	11.5	61	N°4-M12	—	—	
	<b>ME 132</b>	10	41.3	38	300	265	230	5	20	115.5	8	82.5	N°4-M12	—	—	
	<b>ME 160</b>	12	45.3	42	350	300	250	6	20	145	23	110.5	N°4-M16	—	—	
	<b>ME 180</b>	14	51.8	48	350	300	250	6	20	145	23	110.5	N°4-M16	—	—	

	Input type	Shaft			Flange											
		A	B	C	D	E	F	G	H	L	M	N	P	R	S	T
RE 311-511 RE 611 - 612 RE 812-1022 RE 1522 - 2002 - 2002L RE 2003 RE 2523 - 3003 RE 3513 - 4803 RE 6003 - 6003L RE 6004 - 6004L RE 8004 - 8004L GB 12004 - 12004L GB 16004 - 16004L GB 21004 - 21005 GB 26005 - 31005 GB 40005 - 45005 GB 53005 CC350	<b>ME132</b>	10	41.3	38	300	265	230	5	20	125.5	8	82.5	N°4-M12	—	—	236
	<b>ME160</b>	12	45.3	42	344	300	250	7	20	154.5	23	110.5	N°4-M16	—	—	
	<b>ME180</b>	14	51.8	48	344	300	250	7	20	154.5	23	110.5	N°4-M16	—	—	
	<b>ME225</b>	18	64.4	60	450	400	350	7	20	191.5	30	143.5	N°4-M16	—	—	

	Input type	Shaft			Flange											
		A	B	C	D	E	F	G	H	L	M	N	P	R	S	T
RE 811 RE 1021 RE 2522 RE 3002 RE 3512 RE 8003 - 8003L GB 12013 - 12013L GB 16003L GB 26004 GB 31004 GB 40004 GB 85005 GB 110005 CC600 - CC1000	<b>ME200</b>	16	59.3	55	400	350	300	7	18	165	11.5	114.5	N°4-M18	—	—	285
	<b>ME225</b>	18	64.4	60	450	400	350	7	20	194	30.5	143.5	N°8-M18	—	—	
	<b>ME250</b>	18	6.4	65	550	500	450	7	22	195	17	145	N°8-ø19	—	—	
	<b>ME280</b>	20	79.9	75	550	500	450	7	22	195	12	145	N°8-ø19	—	—	

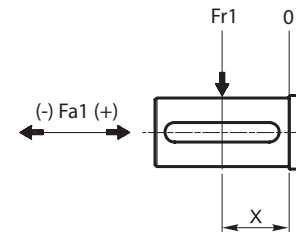
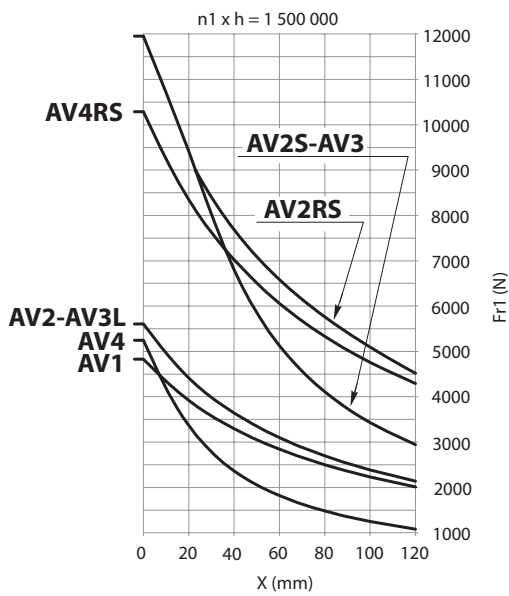
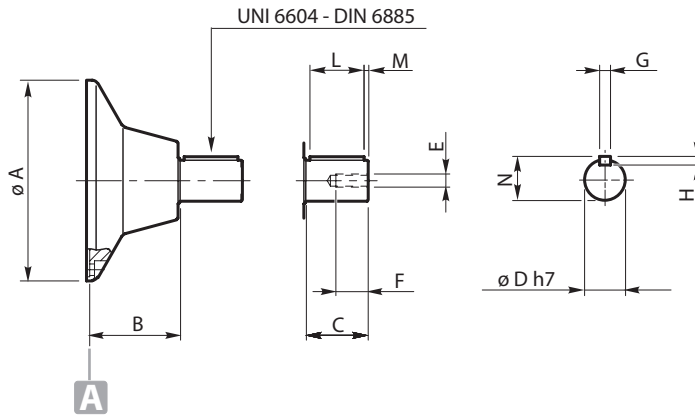
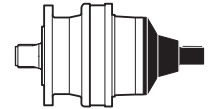

	n1 x h = 1 500 000 Fa1 max (Fr1 = 0)	
	Fa1 (+)	Fa1 (-)
<b>AV1</b>	4 800	4 800
<b>AV2 - AV3L - AV4</b>	7 800	7 800
<b>AV2S - AV3</b>	4 900	7 800
<b>AV2RS - AV4RS</b>	4 900	4 900

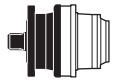

	Type	øA	B	C	øD	E	F	G	H	L	M	N	Code
RE 111 - 112 - 113 - 114	<b>AV1</b> <b>AV2</b> <b>AV3L</b> <b>AV4</b> <b>AV4RS</b>	186	83.5	58	38	M12	30	10	8	50	4	41	K0700AH
RE 211 - 212 - 213 - 214													
RE 241 - 242 - 243 - 244													
RE 312 - 313 - 314													
RE 512 - 513 - 514													
RE 613 - 614 - 813 - 814													
RE 1023 - 1024 - 1523 - 1524													
RE 2000 - 2524 - 3004 - 3514													
RE 4804 - 6004L - 8005 - 8005L	186	108.5	65	40	M12	30	12	8	60	2.5	43	K0700AX	
GB 12015 - 12015L													
GB 16005 - 16005L													
CC30-CC120													

	Type	øA	B	C	øD	E	F	G	H	L	M	N	Code
RE 311-511-611-612	<b>AV2</b> <b>AV2S</b> <b>AV2RS</b> <b>AV3</b> <b>AV4</b> <b>AV4RS</b>	244	106	82	42	M12	30	12	8	70	6	45	K0700DL
RE 812-1022-1522-2003													
RE 2523-3003-3513-4803													
RE 6003-6003L-6004-6004L													
RE 8004-8004L													
GB 12014-12014L-16004-16004L													
GB 21004-21005-26005-31005													
GB 40005-45005-53005													
GB 61005	244	118	65	40	M12	30	12	8	60	2.5	43	K0700DJ	
GB 12015 - 12015L													
GB 16005 - 16005L													
CC350-CC600													

# AVF-AV110N-NL

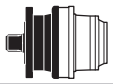
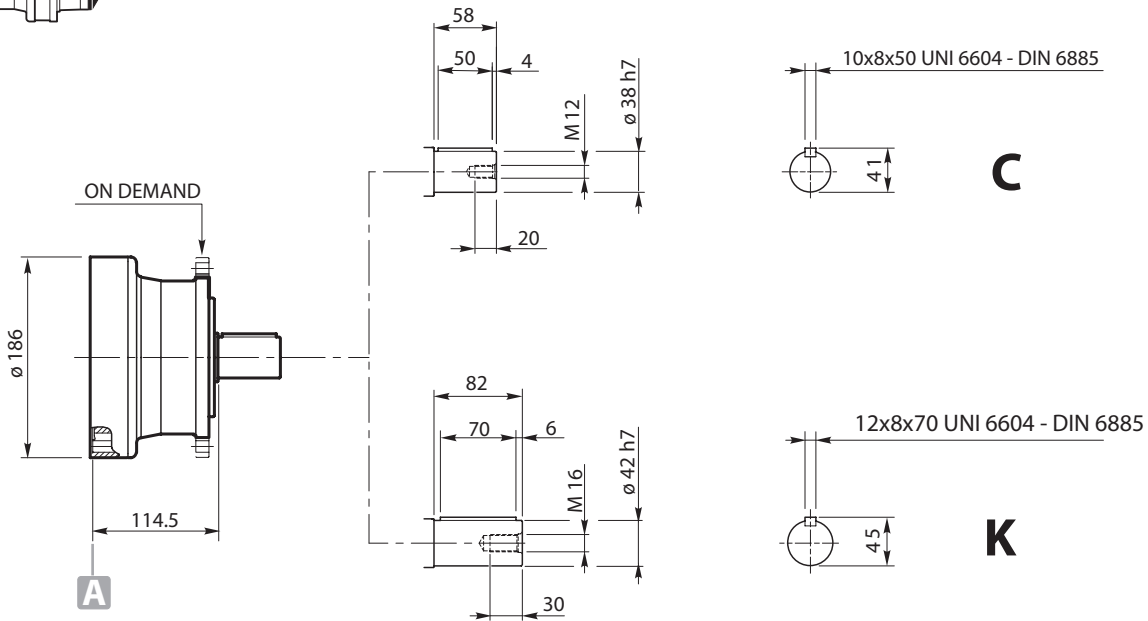
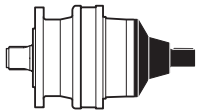

Code
RE 111 - 112 - 113 - 114
RE 211 - 212 - 213 - 214
RE 241 - 242 - 243 - 244
RE 312 - 313 - 314
RE 512 - 513 - 514
RE 613 - 614
RE 813 - 814
RE 1023 - 1024
RE 1523 - 1524
RE 2004
RE 2524
RE 3004
RE 3514
RE 4804
RE 6004L
RE 8005 - 8005L
GB 12015 - 12015L
GB 16005 - 16005L
CC30-CC120

Code
K0700AY

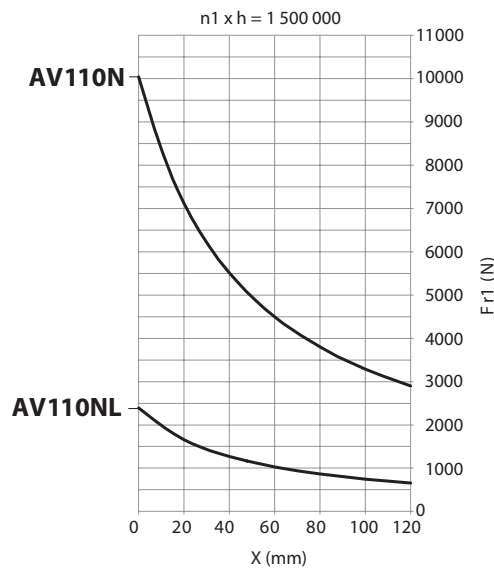

n1 x h = 1 500 000	
Fa1 max (Fr1 = 0)	
Fa1 (+)	Fa1 (-)
AV110N	4 900
AV110NL	3 750

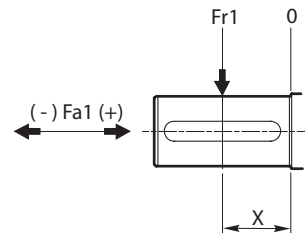
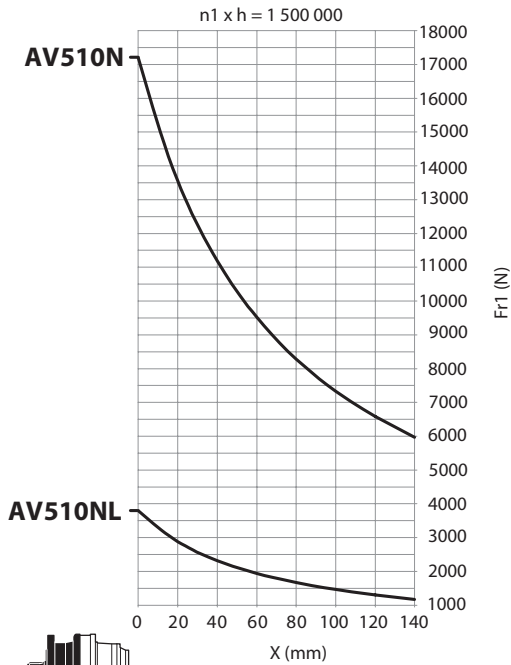
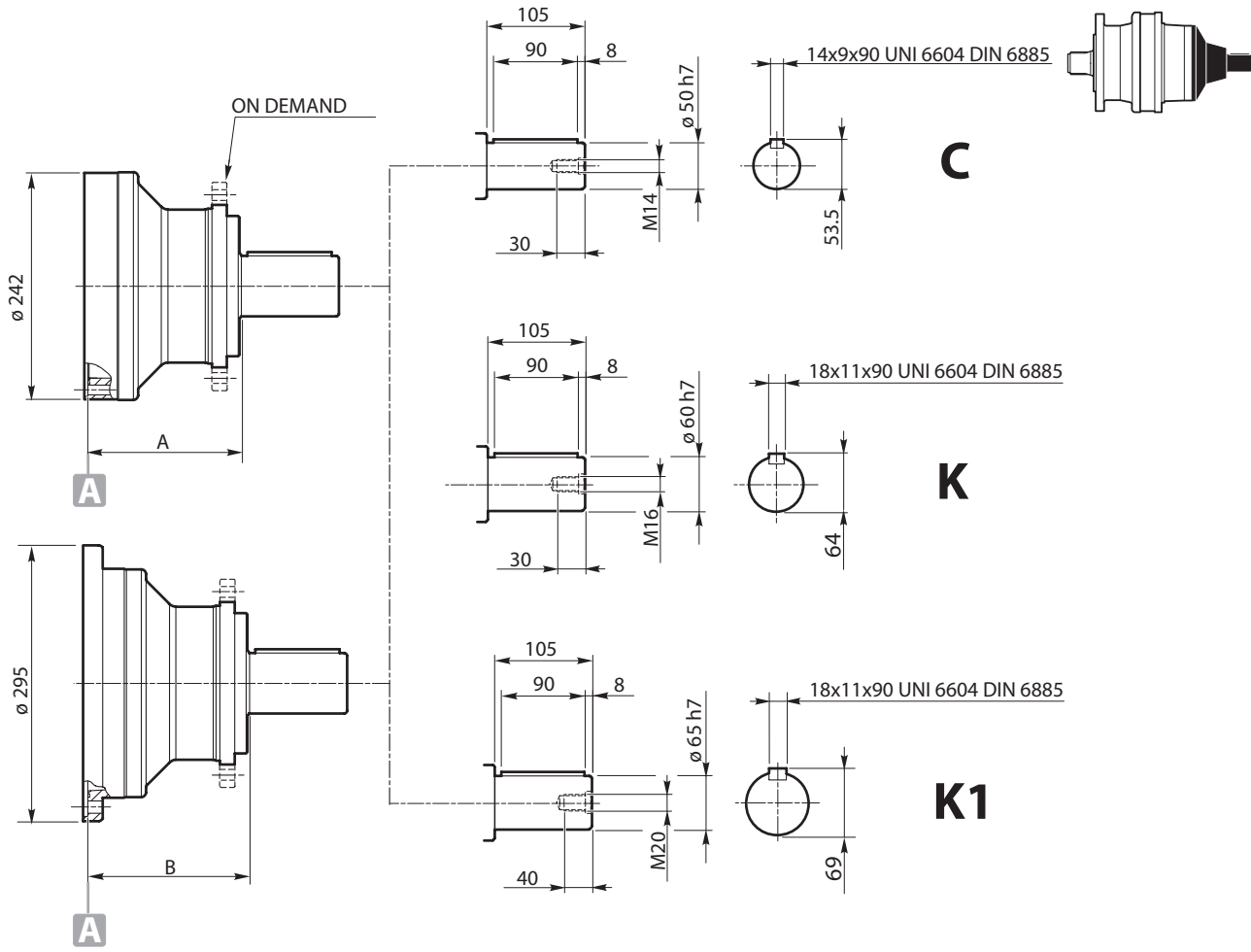

n1 x h = 1 500 000 Fa1 max (Fr1 = 0)		
	Fa1 (+)	Fa1 (-)
AV510NL	6 600	6 600
AV510N	15 250	15 250



	A	B
RE 311-511-611-612-812-1022-1522-2003-2523-3003-3513-4803-6003-6003L	164	—
RE 6004-6004L-8004-8004L	164	—
GB 12014-12014L-16004-16004L-21004-21005-26005-31005-40005-45005	164	—
GB 53005-61005	—	172.5
RE 811-1021-2522-3002-3512-8003-8003L	—	172.5
GB 12013-12013L-16003L-26004-31004-40004-85005-110005	—	172.5
CC350	128	—
CC600	—	153

# AVF-AV510TL

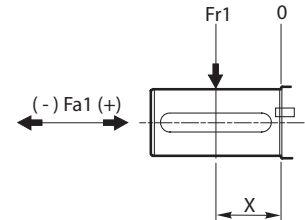
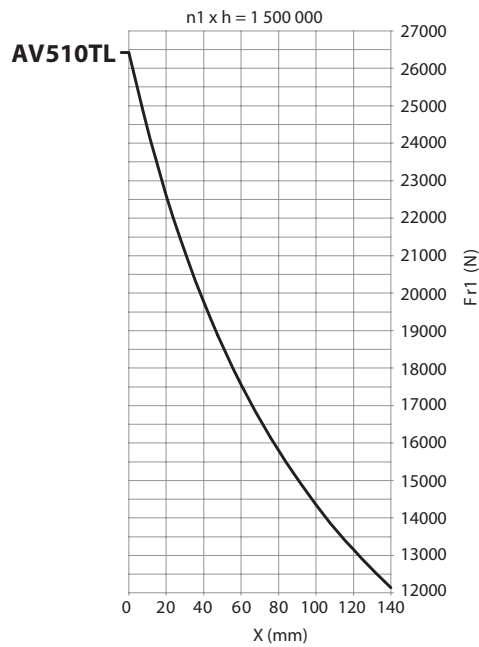
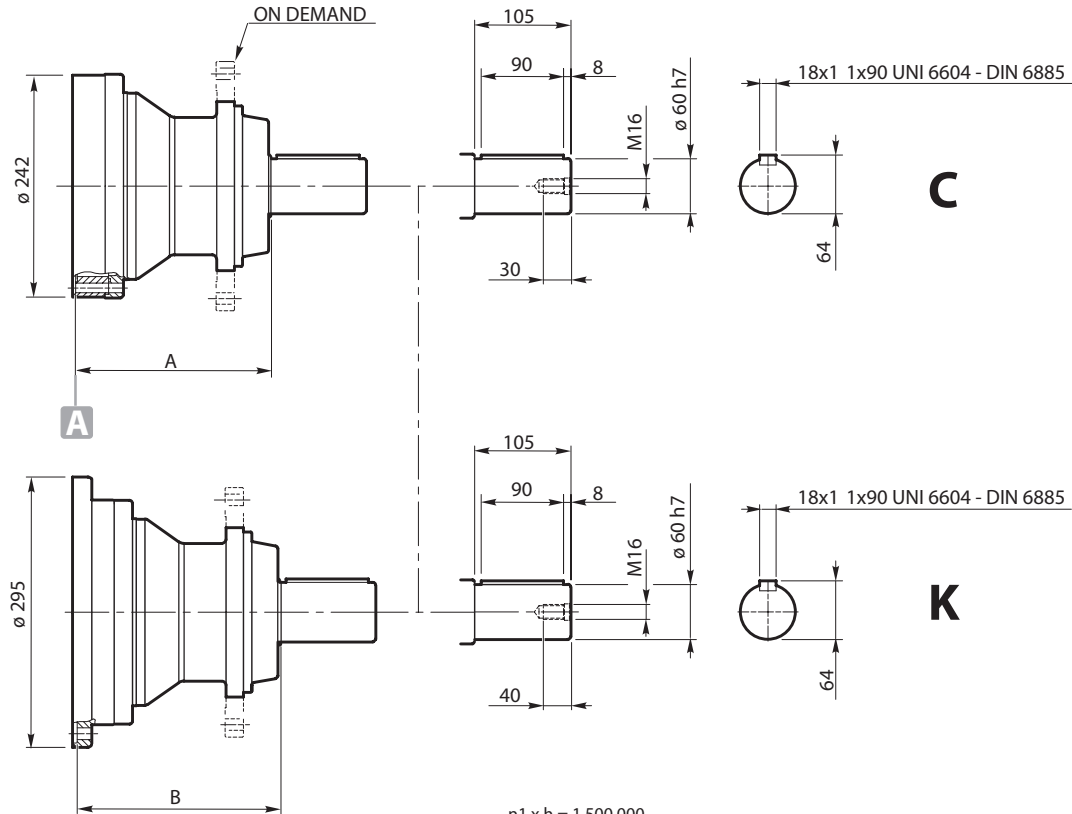
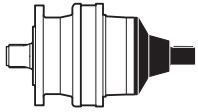

n1 x h = 1 500 000		
Fa1 max (Fr1 = 0)		
	Fa1 (+)	Fa1 (-)
<b>AV510TL</b>	21 600	21 600



	A	B
RE 311-511-611-612-812-1022-1522-2003-2523-3003-3513-4803-6003-6003L	212	—
RE 6004-6004L-8004-8004L	212	—
GB 12014-12014L-16004-16004L-21004-21005-26005-31005-40005-45005	212	—
GB 53005-61005	212	—
RE 811-1021-2522-3002-3512-8003-8003L	—	221
GB 12013-12013L-16003L-26004-31004-40004-85005-110005	—	221
CC350	176	—
CC600	—	201

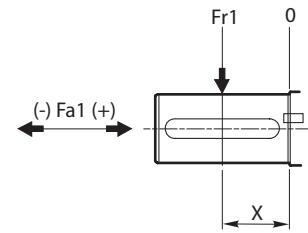
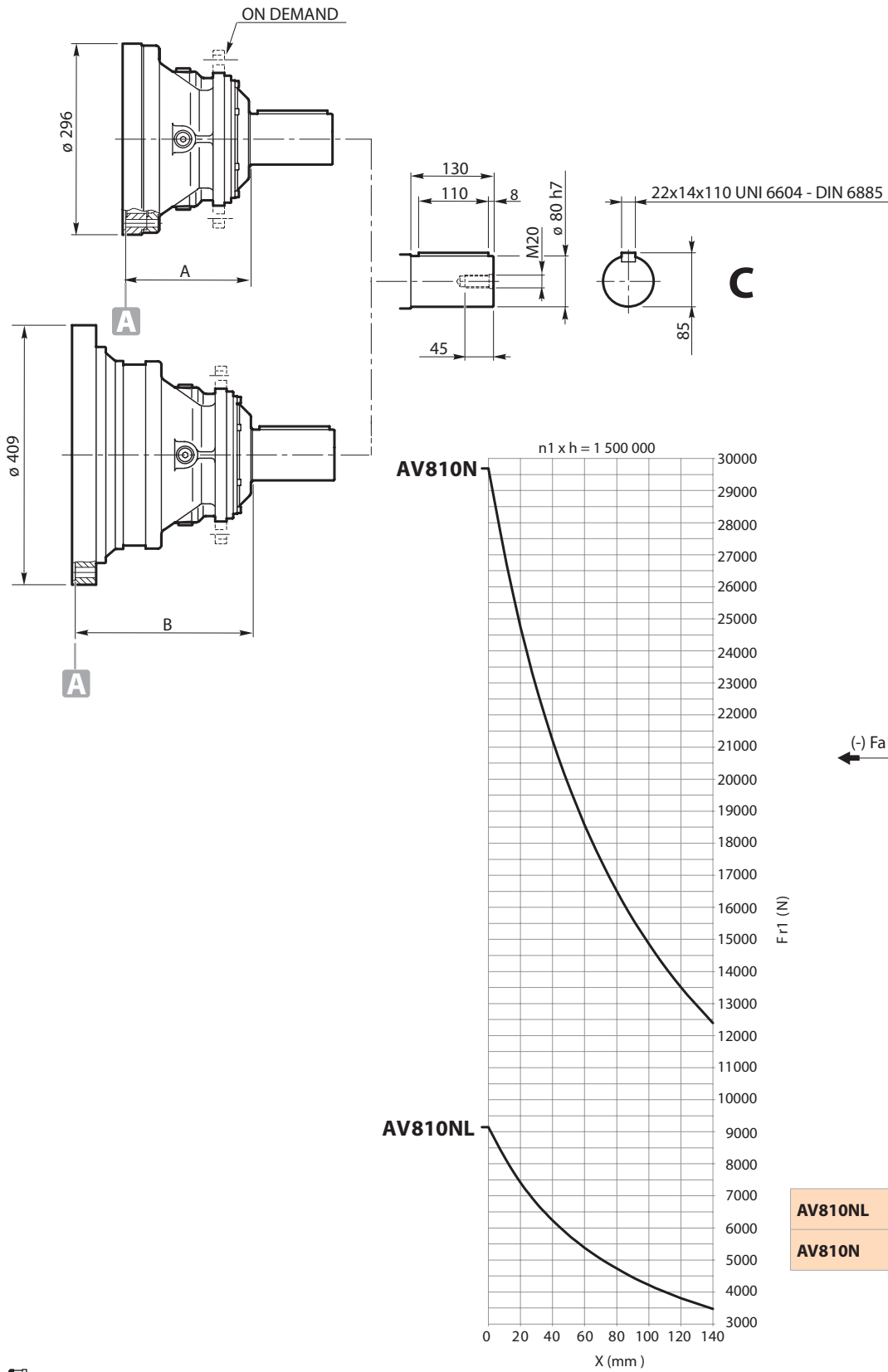
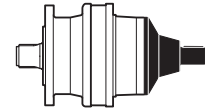

n1 x h = 1 500 000		
Fa1 max (Fr1 = 0)		
	Fa1 (+)	Fa1 (-)
<b>AV810NL</b>	14 800	14 800
<b>AV810N</b>	25 900	25 900



	<b>A</b>	<b>B</b>
<b>RE 811-1021-2522-3002-3512-8003-8003L</b>	195.5	—
<b>GB 12013-12013L-16003L-26004-31004-40004-85005-110005</b>	195.5	—
<b>RE 2521-3001-8002-8002L</b>	—	278
<b>GB 12012-12012L-26003-31003-40003-85004-110004-205005-235005</b>	—	278
<b>CC600</b>	162.5	—
<b>CC1000</b>	162.5	—

# AVF-AV810T-TL

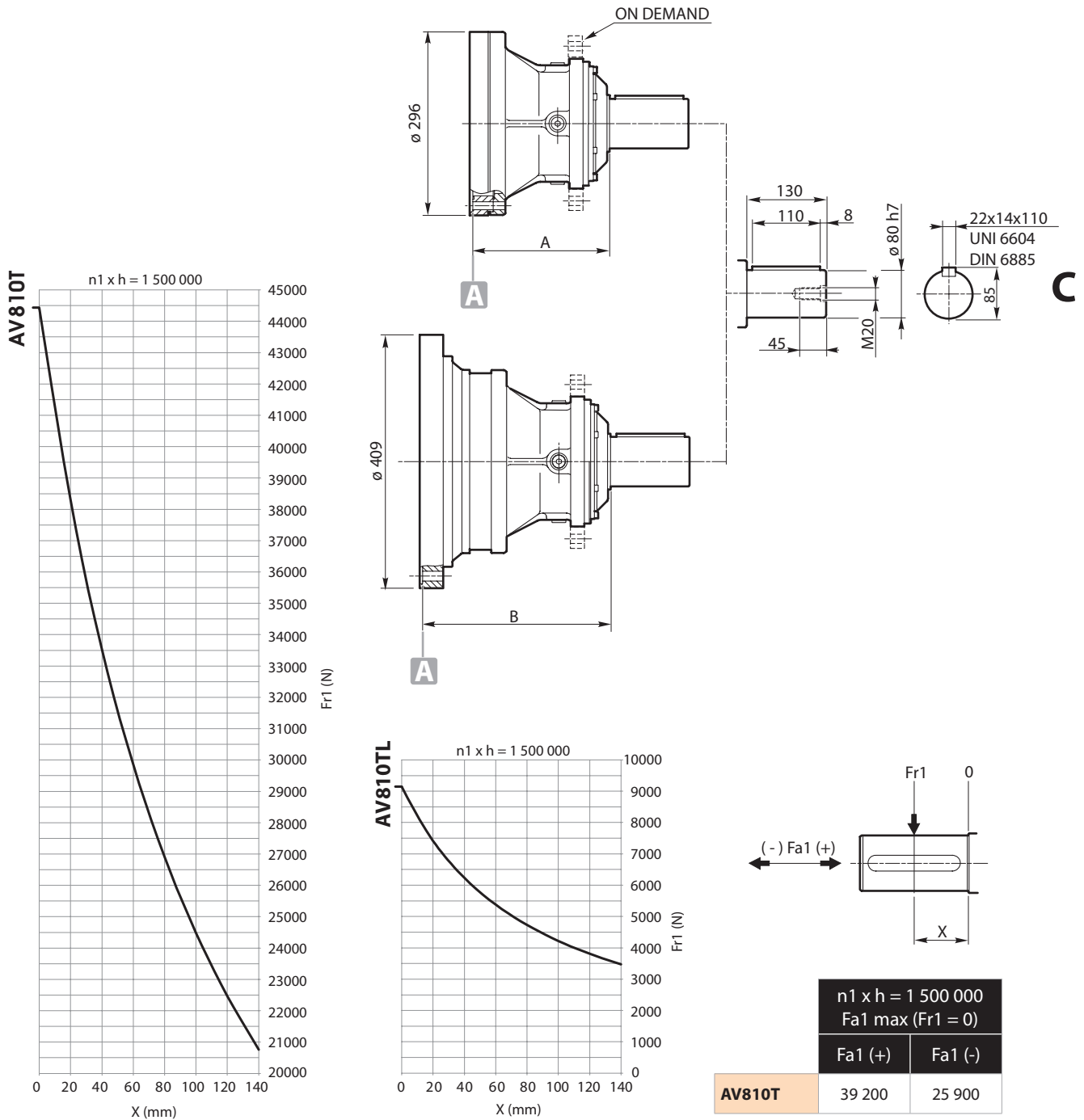
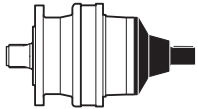

n1 x h = 1 500 000	
Fa1 max (Fr1 = 0)	
Fa1 (+)	Fa1 (-)
<b>AV810T</b>	39 200
	25 900



	A	B
RE 811-1021-2522-3002-3512-8003-8003L	218	—
GB 12013-12013L-16003L-26004-31004-40004-85005-110005	218	—
RE 2521-3001-8002-8002L	—	296
GB 12012-12012L-26003-31003-40003-85004-110004-205005-235005	—	296
CC600	185	—
CC1000	185	—

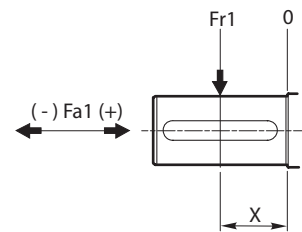
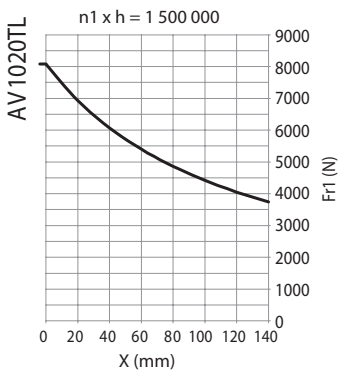
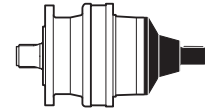
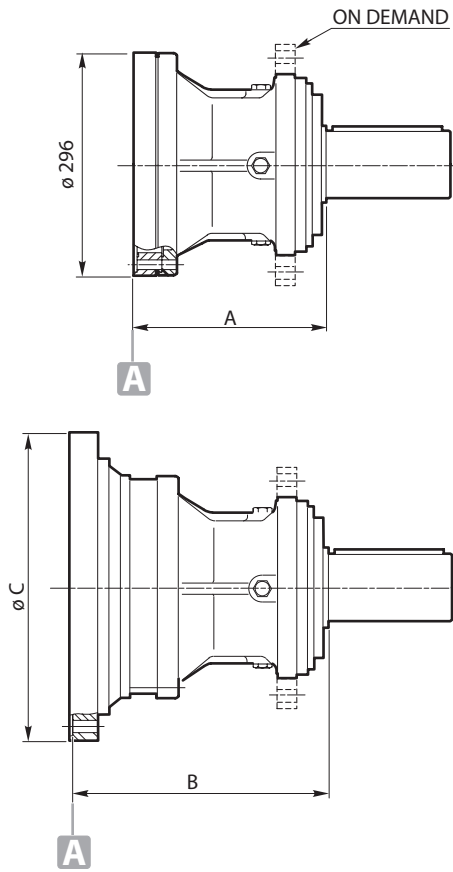
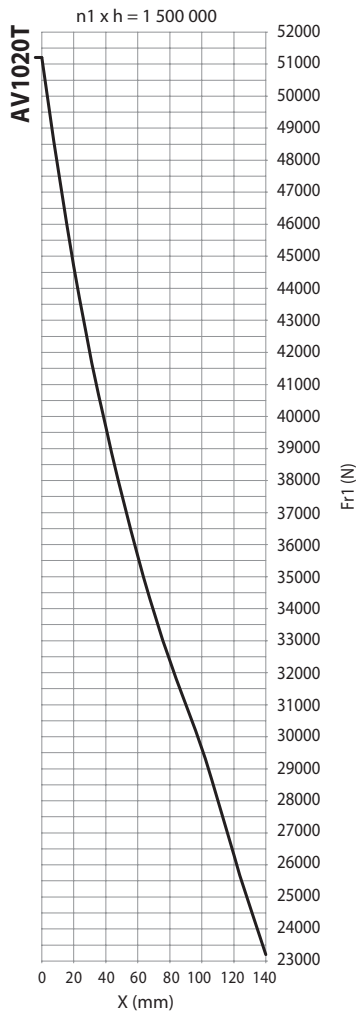

n1 x h = 1 500 000		
Fa1 max (Fr1 = 0)		
	Fa1 (+)	Fa1 (-)
<b>AV1020T</b>	46 450	26 850

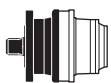

	A	B	C
RE 811-1021-2522-3002-3512-8003-8003L	249	—	—
GB 12013-12013L-16003L-26004-31004-40004-85005-110005	249	—	—
RE 2521-3001-8002-8002L	—	327	409
GB 12012-12012L-26003-31003-40003-85004-110004	—	327	409
RE 3511-4801	—	348	452
GB 16002-16002L-45003-130004	—	348	452
CC1000	216	—	—

# AVF-AV1520T

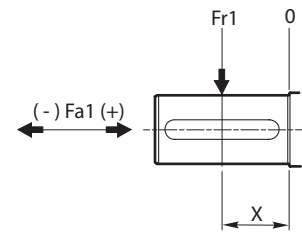
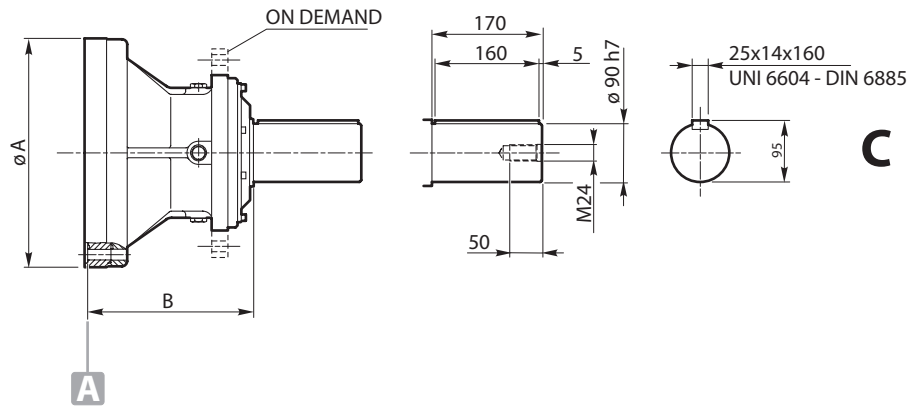
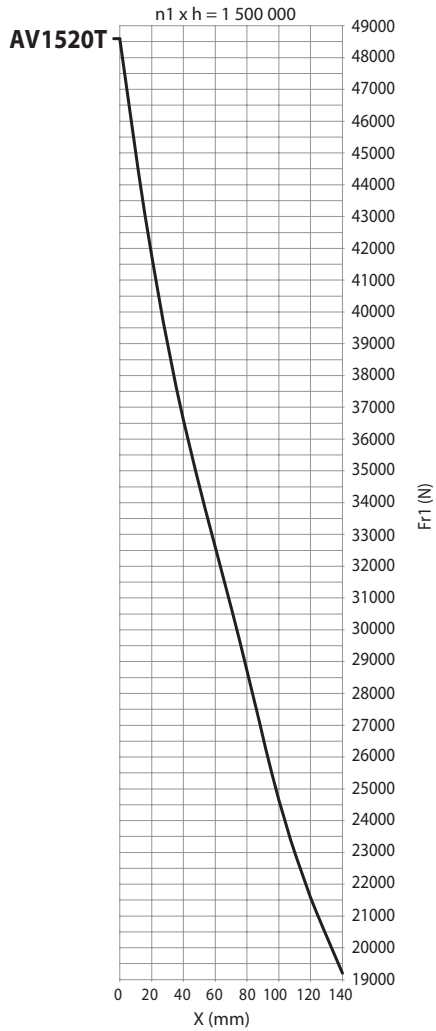
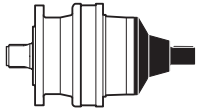

$n1 \times h = 1\,500\,000$	
Fa1 max (Fr1 = 0)	
Fa1 (+)	Fa1 (-)
<b>AV1520T</b>	8 500



	A	B
RE 1521-2001-6002-6002L	353	252
GB 21003-45004-53004-61004-130005	353	252
RE 6001	490	321
GB 21002-53003-61003-150004	490	321

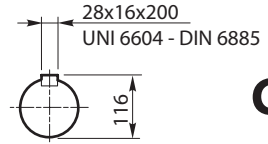
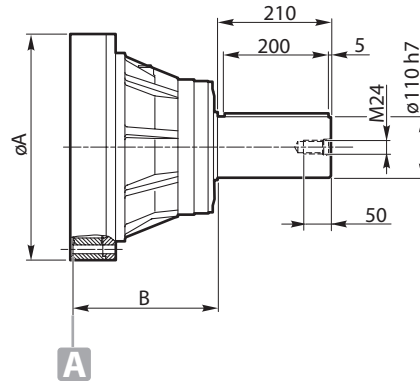
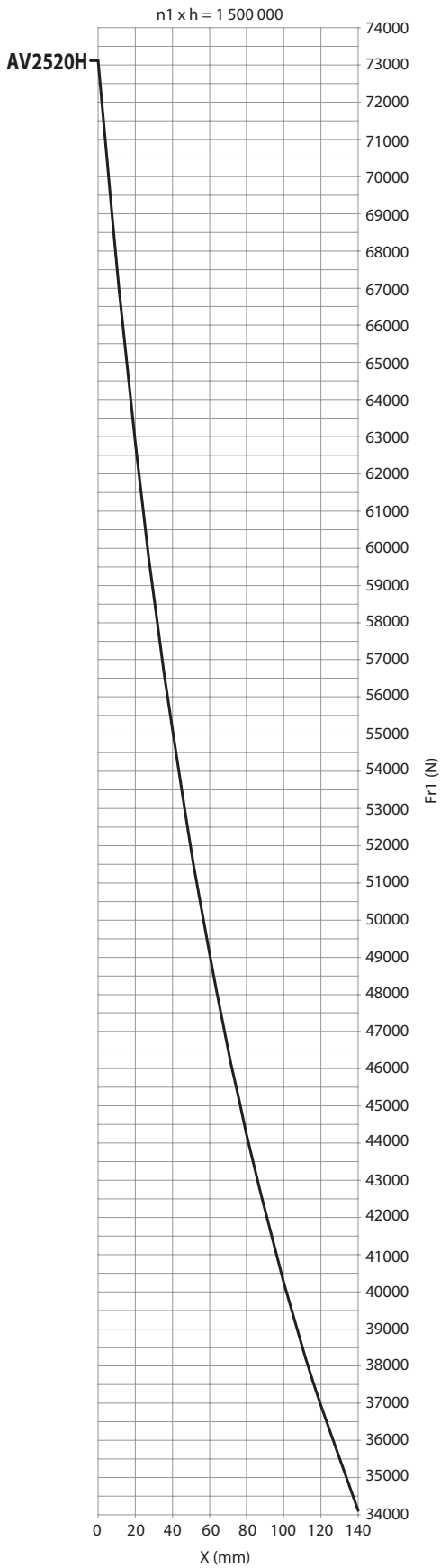

	$n1 \times h = 1\,500\,000$ Fa1 max (Fr1 = 0)	
	Fa1 (+)	Fa1 (-)
<b>AV2520H</b>	66 000	50 000
<b>AV2520HL</b>	29 700	29 700

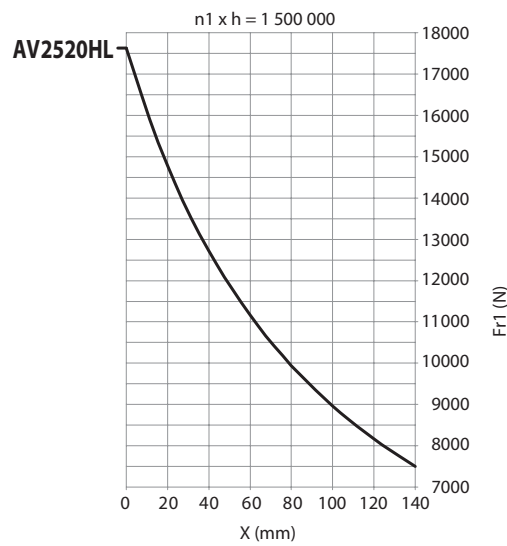
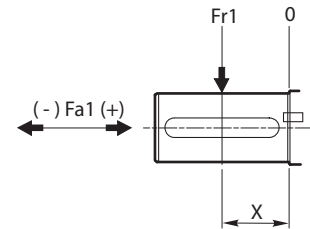

	<b>A</b>	<b>B</b>
<b>RE 2521-3001-8002-8002L</b>	409	257
<b>GB 12012-12012L--26003-31003-40003</b>	409	257
<b>GB 85004-110004-205005-235005</b>	452	320
<b>RE 3511-4801</b>	452	320
<b>GB 16002-16002L-45003-130004</b>	490	293
<b>RE 6001</b>	490	293
<b>GB 21002-53003-61003-150004</b>	490	385
<b>RE 8001</b>	490	385
<b>GB 26002-85003</b>	368	610
<b>GB 12011-16001-31002-40002-45002-110003</b>		
<b>GB 130003-205004-235004</b>		

# AV80

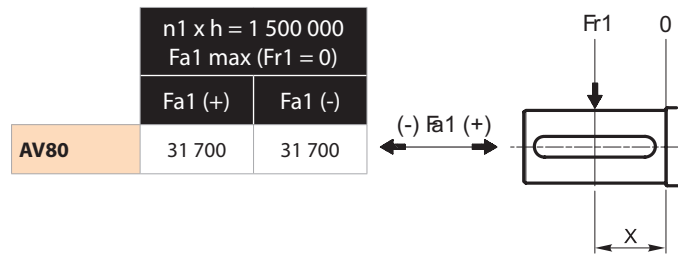
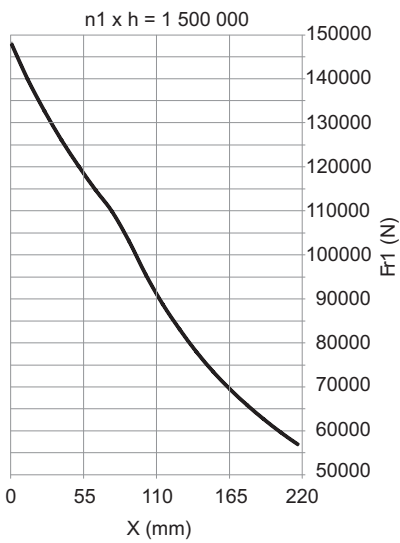
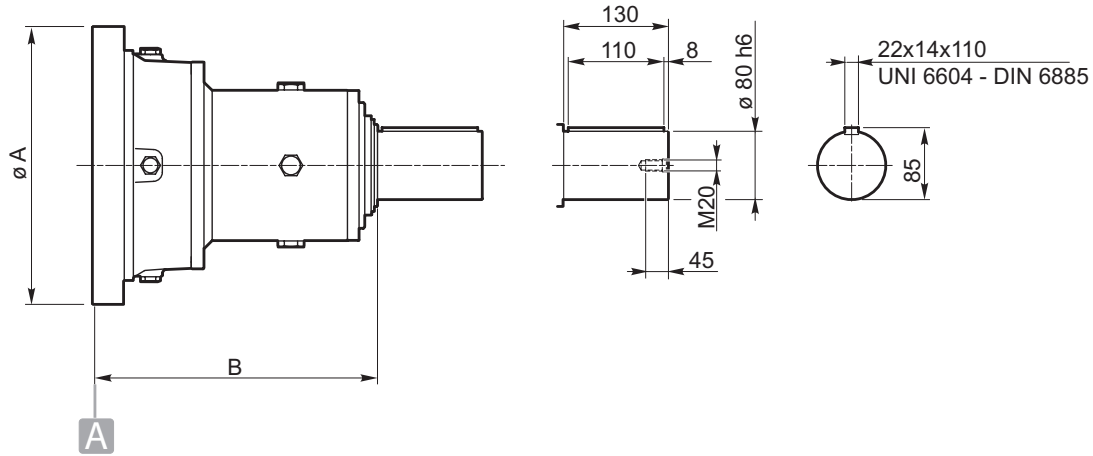
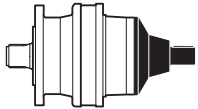

	A	B
RE 811-1021-2522-3002-3512-80003-8003L	295	187.5
GB 12013-12013L-16003L-260004-31004-40004-85005-110005	295	187.5
RE 2521-3001-8002-8002L	409	298
GB 12012-12012L-26003-31003-40003-85004-110004-205003	409	298

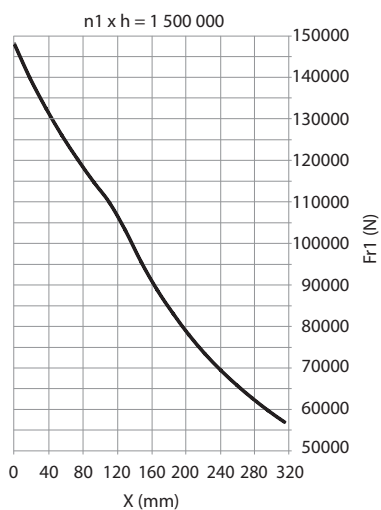
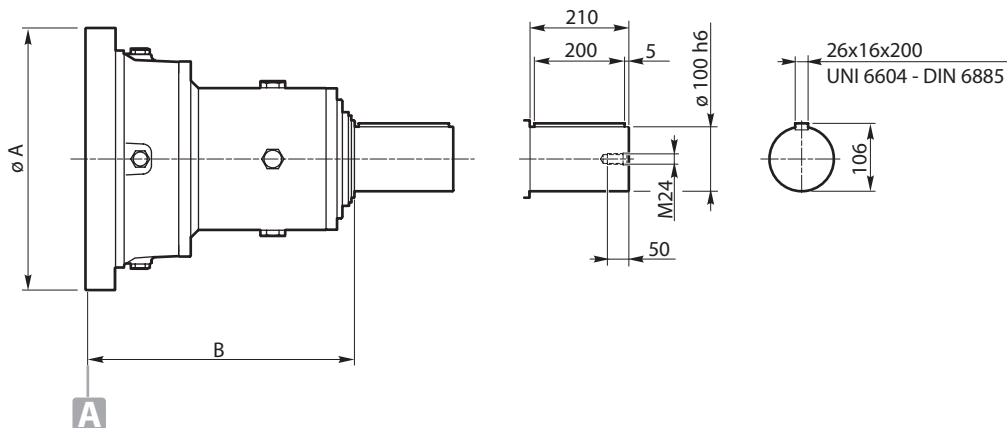
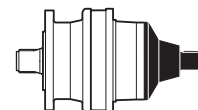

	n1 x h = 1 500 000 Fa1 max (Fr1 = 0)	
	Fa1 (+)	Fa1 (-)
<b>AV100</b>	52 000	-



	<b>A</b>	<b>B</b>
<b>RE 3511-4801</b>	452	464.5
<b>GB 16002-45003-130004</b>	452	464.5
<b>RE 6001-8001</b>	490	437
<b>GB 21002-26002-53003-61003-85003-150004</b>	490	437
<b>GB 12011-16001</b>	610	550
<b>GB 31002-40002-45002-110003-130003-150003-205004-235004</b>	610	550

# AV150

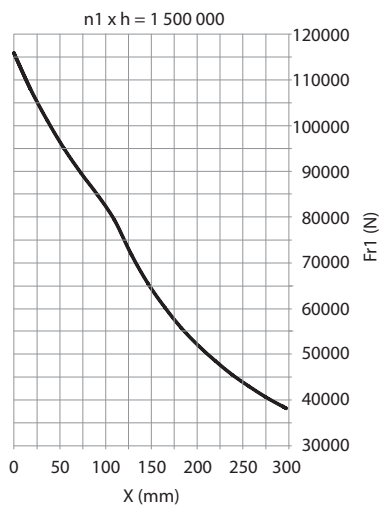
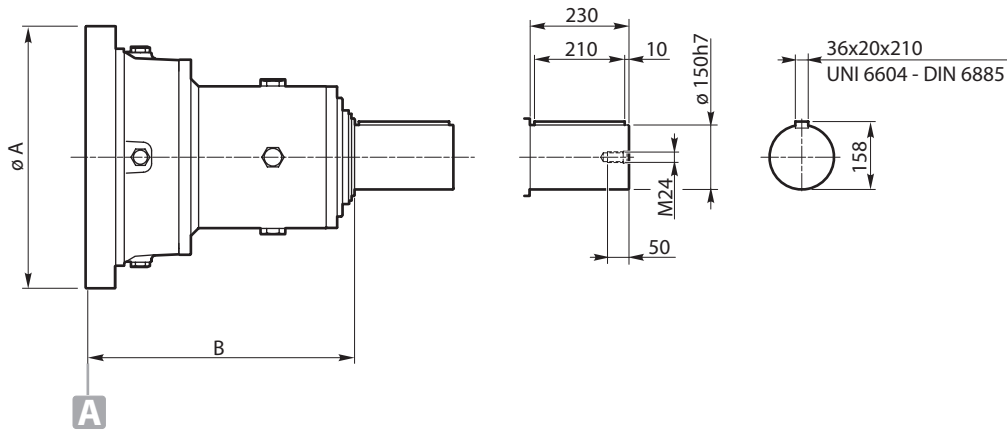
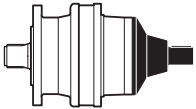

n1 x h = 1 500 000	
Fa1 max (Fr1 = 0)	
Fa1 (+)	Fa1 (-)
<b>AV150</b>	-

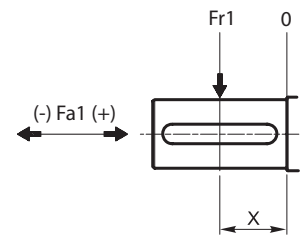

	A	B
RE 6001-8001	490	634
GB 21002-26002-53003-61003-150004	490	634
GB 12011-16001	610	626
GB 31002-40002-45002-110003-130003-15000-205004-235004	610	626

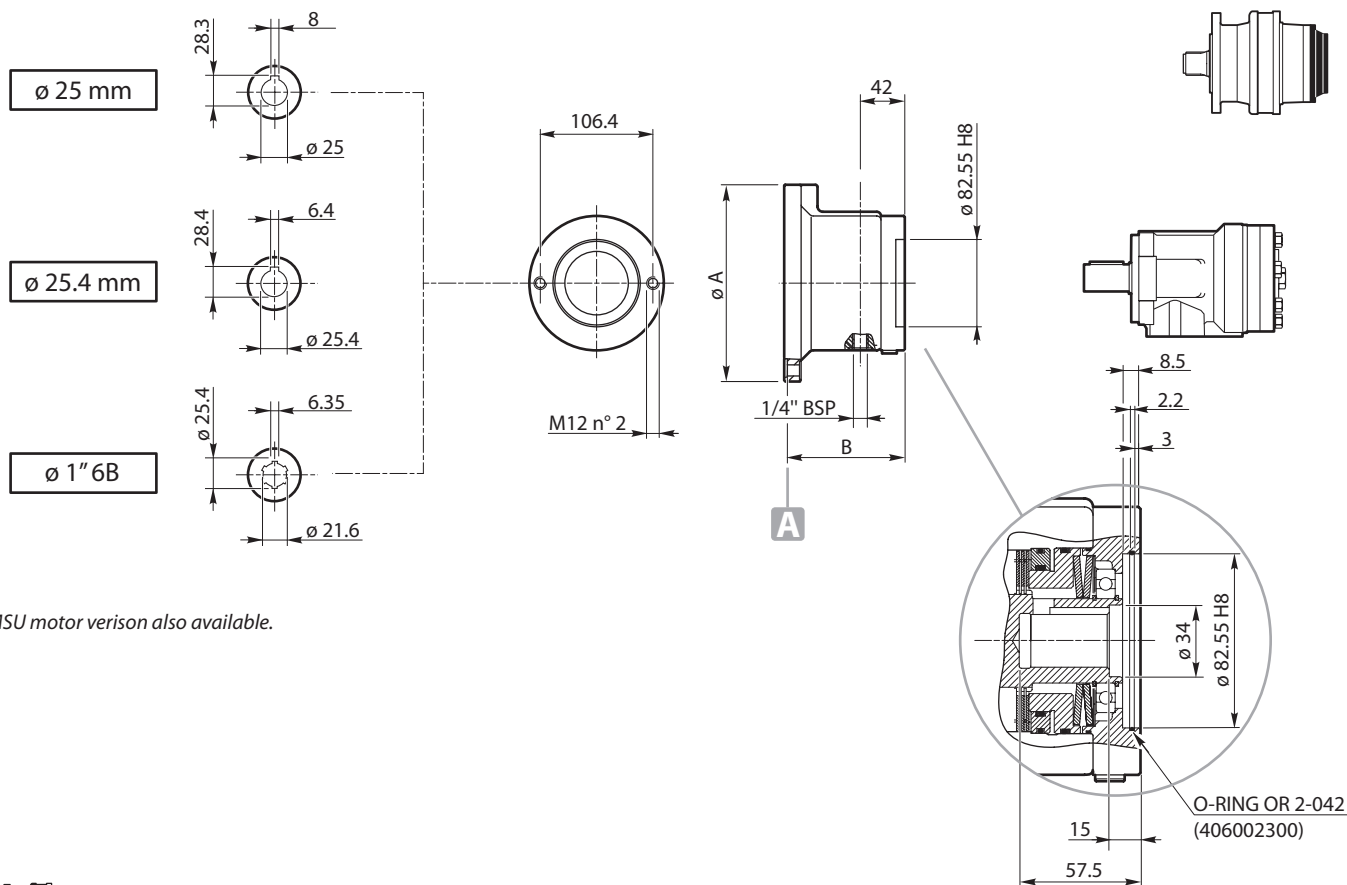

OMSU motor version also available.



	∅ A	B		F 01	F 10	F 11	F 12	F 13	F 14	F 05	F 16		
RE 111 - 112 - 113 - 114 RE 211 - 212 - 213 - 214 RE 241 - 242 - 243 - 244 RE 312 - 313 - 314 RE 512 - 513 - 514 RE 613 - 614 RE 813 - 814 RE 1023 - 1024 RE 1523 - 1524 RE 2004 RE 2524 RE 3004 RE 3514-4804 RE 6004L RE 8005 - 8005L GB 12015 - 12015L GB 16005 - 16005L CC30-CC120	186	109.5	<b>Tb (Nm)</b>	132	133	182	235	332	468	530	608	±5%	
			<b>pb (bar)</b>	23	29	34	26	30	36	39	42		
			<b>p max (bar)</b>	300									
			<b>n1 max (RPM)</b>	700									

	∅ A	B		F 02	F 20	F 21	F 22	F 23	F 24	F 25	F 26		
RE 311-511 RE 611 - 612 RE 812-1022 RE 1522-2003 RE 2523-3003 RE 3513-4803 RE 6003 - 6003L RE 6004 - 6004L RE 8004 - 8004L GB 12014 - 12014L GB 16004 - 16004L GB 21004 - 21005 GB 26005-31005 GB 40005-45005 GB 53005 CC350	244	118.5	<b>Tb (Nm)</b>	132	133	182	235	332	468	530	608	±5%	
			<b>pb (bar)</b>	23	29	34	26	30	36	39	42		
			<b>p max (bar)</b>	300									
			<b>n1 max (RPM)</b>	700									

# F5-F6

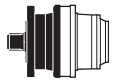
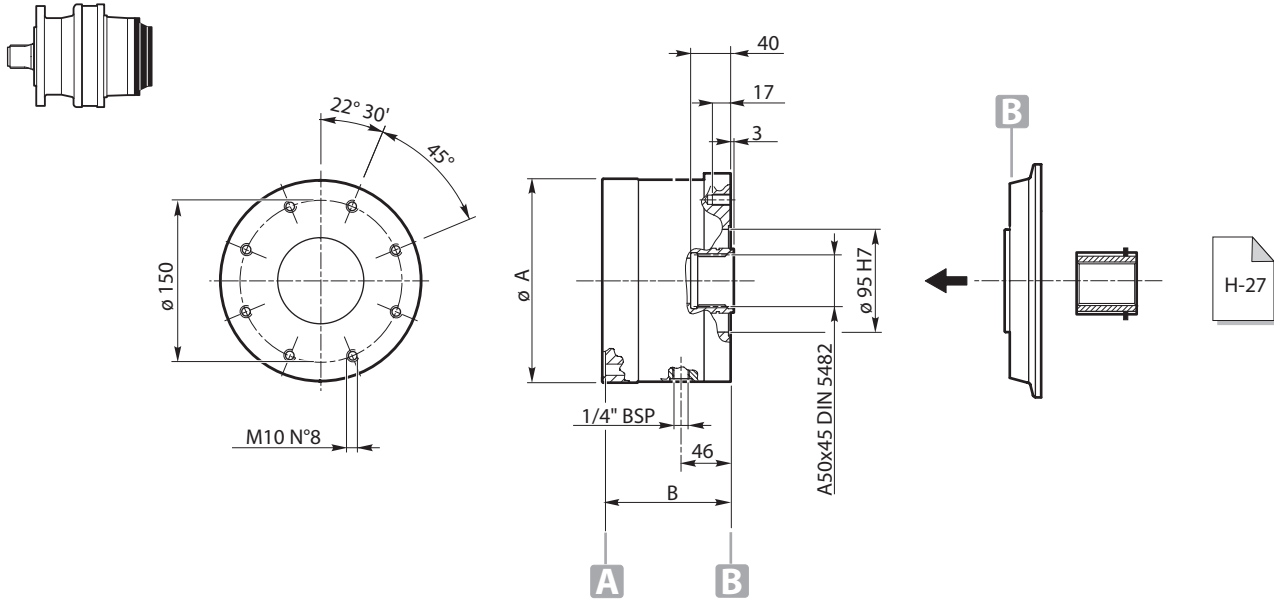

	∅ A	B	F 501	F 502	F 503	F504	F505	F506	F 508	
RE 111 - 112 - 113 - 114 RE 211 - 212 - 213 - 214 RE 241 - 242 - 243 - 244 RE 312 - 313 - 314 RE 512 - 513 - 514 RE 613 - 614 RE 813 - 814 RE 1023 - 1024 RE 1523 - 1524 RE 2004 RE 2524 RE 3004 RE 3514-4804 RE 6004L RE 8005 - 8005L GB 12015 - 12015L GB 16005 - 16005L CC30 CC120	186	115								±5%
<b>Tb (Nm)</b>			110	215	325	405	500	630	818	
<b>pb (bar)</b>			10	20	30	38	28	35	33	
<b>p max (bar)</b>			300							
<b>n1 max (RPM)</b>			1500 (standard)							
			3500 (special)							

	∅ A	B	F 601	F 602	F 603	F604	F 605	F 606	F608	F610	F612	
RE 311-511 RE 611 - 612 RE 812-1022 RE 1522-2003 RE 2523-3003 RE 3513-4803 RE 6003 - 6003L RE 6004 - 6004L RE 8004 - 8004L GB 12014 - 12014L GB 16004 - 16004L GB 21004 - 21005 GB 26005-31005 GB 40005-45005 GB 53005 CC350	244	125										±5%
<b>Tb (Nm)</b>			110	215	325	405	500	630	818	1005	1150	
<b>pb (bar)</b>			10	20	30	38	28	35	33	40	40	
<b>p max (bar)</b>			300									
<b>n1 max (RPM)</b>			1500 (standard)									
			3500 (special)									

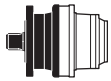
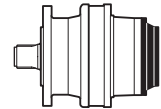
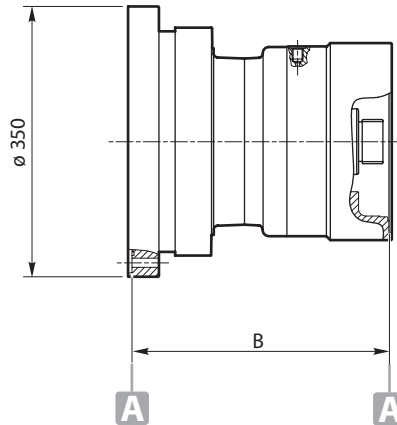
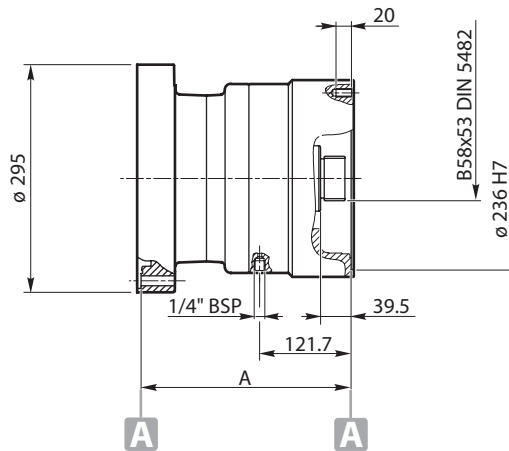
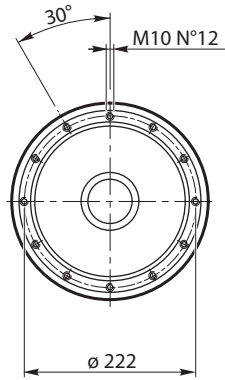

	A	B		F 813	F 815	F 818	F 820	F 823	F 827	F 830	
RE 811	272.5	-	<b>Tb</b> (Nm)	1271	1525	1780	2034	2288	2670	3051	±5%
RE 1021	-	314.5									
RE 1521-2001	272.5	-	<b>pb</b> (bar)	54	65	76	58	65	76	87	
RE 2522-3002	272.5	-									
RE 3512-4801	-	314.5	<b>p max</b> (bar)	300							
RE 6002-6002L	272.5	-									
RE 8003-8003L	272.5	-	<b>n1 max</b> (RPM)	1500 (standard)							
GB 12013-12013L	272.5	-									
GB 16003L	-	314.5	3500 (special)								
GB 16003	-	314.5									
GB 21003	272.5	-									
GB 26004	272.5	-									
GB 31004	272.5	-									
GB 40004	-	314.5									
GB 45004	-	314.5									
GB 53004	-	314.5									
GB 61004	272.5	-									
GB 85005	272.5	-									
GB 110005	-	314.5									
GB 130005	-	314.5									
GB 150005	272.5	-									
CC600	272.5	-									
CC1000	292.5	-									
	292.5	-									

# F8-MU

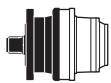
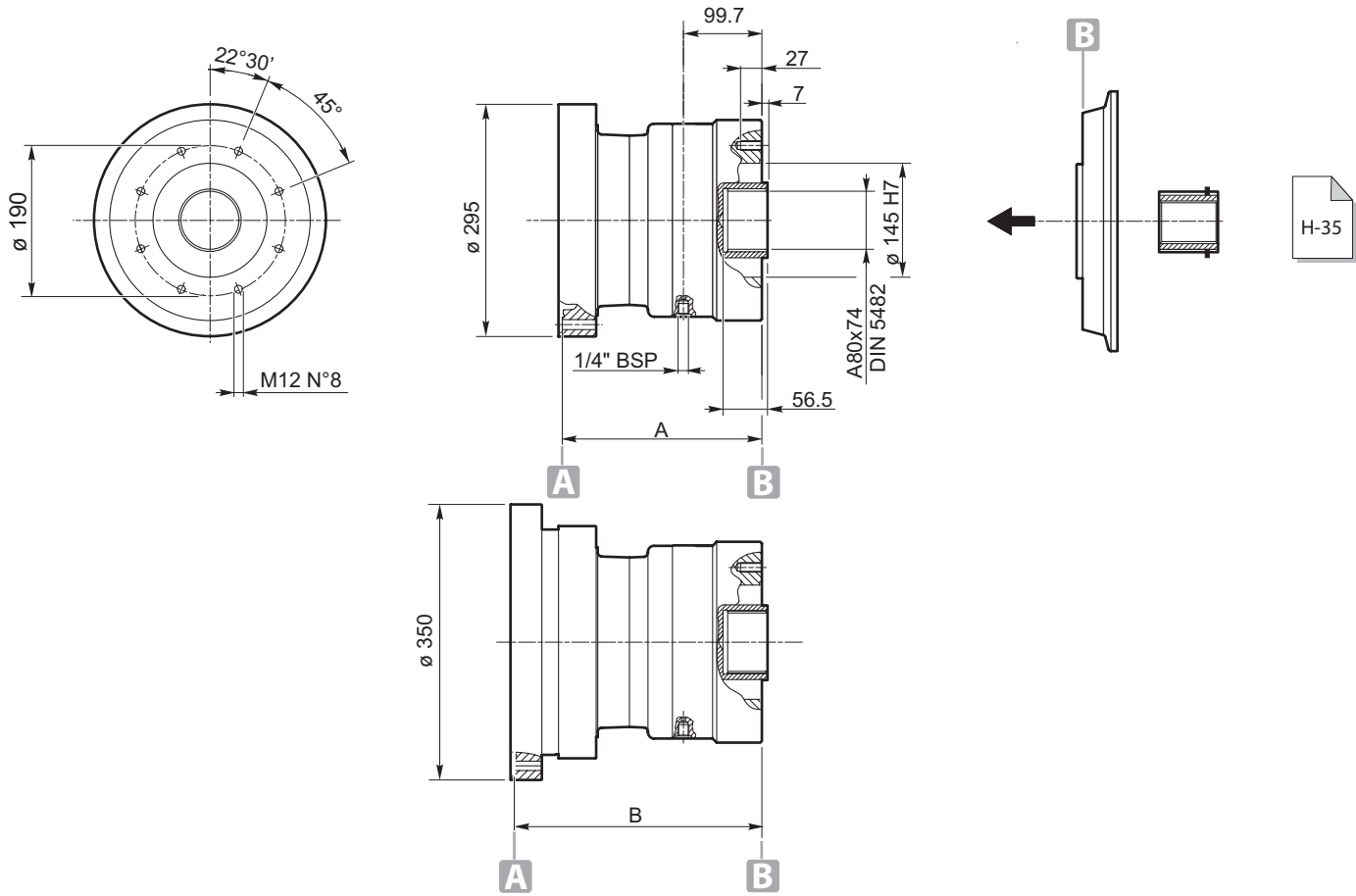
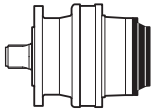

	A	B		F 813	F 815	F 818	F 820	F 823	F 827	F 830	
RE 811	253.5	-	<b>Tb</b> (Nm)	1271	1525	1780	2034	2288	2670	3051	±5%
RE 1021	253.5	-									
RE 1521-2001	-	314.5	<b>pb</b> (bar)	54	65	76	58	65	76	87	
RE 2522-3002	253.5	-									
RE 3512-4801	-	314.5	<b>p max</b> (bar)	300							
RE 6002-6002L	253.5	-									
RE 8003-8003L	253.5	-	<b>n1 max</b> (RPM)	1500 (standard)							
GB 12013-12013L	253.5	-		3500 (special)							
GB 16003L	-	314.5									
GB 16003	-	314.5									
GB 21003	253.5	-									
GB 26004	253.5	-									
GB 31004	253.5	-									
GB 40004	-	314.5									
GB 45004	-	314.5									
GB 53004	-	314.5									
GB 61004	253.5	-									
GB 85005	253.5	-									
GB 110005	-	314.5									
GB 130005	-	314.5									
GB 150005	253.5	-									
CC600	253.5	-									
CC1000	253.5	-									

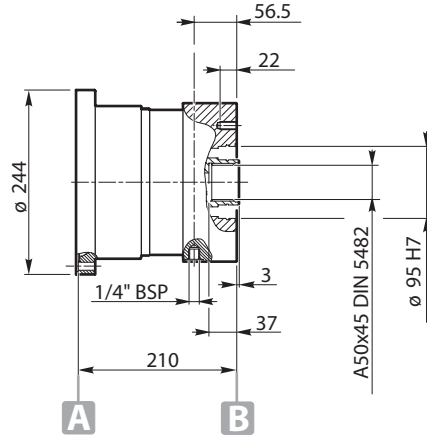
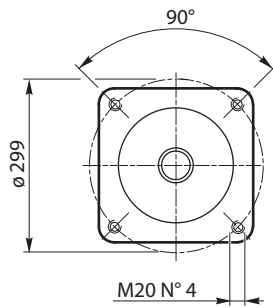
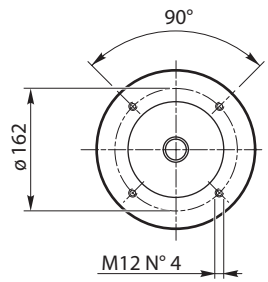
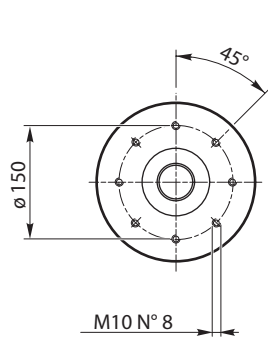

**ST**

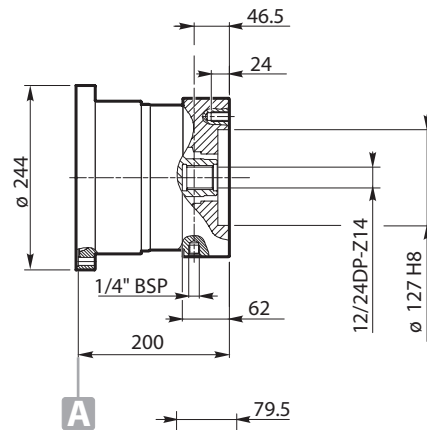
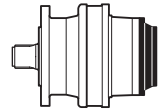

**SAE "C"**

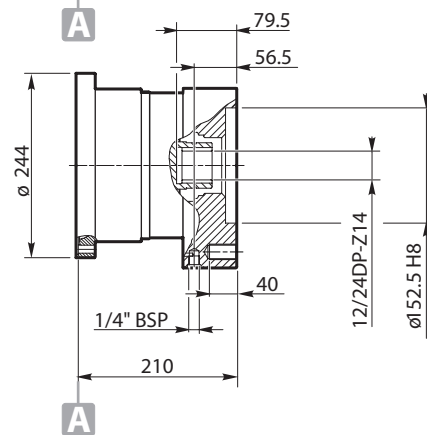

**SAE "D"**

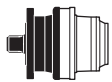

- RE 311-511
- RE 611 - 612
- RE 812-1022
- RE 1522-2003
- RE 2523-3003
- RE 3513-4803
- RE 6003 - 6003L
- RE 6004 - 6004L
- RE 8004 - 8004L
- GB 12014 - 12014L
- GB 16004 - 16004L
- GB 21004 - 21005
- GB 26005-31005
- GB 40005-45005
- GB 53005
- CC350

	F 902	F 903	F 904	F 905	F 906	F 908	F 910	F 912	F 915
--	-------	-------	-------	-------	-------	-------	-------	-------	-------

<b>Tb</b> (Nm)	200	310	400	485	620	770	990	1160	1325
<b>pb</b> (bar)	14	22	19	18	23	23	29	34	38
<b>p max</b> (bar)	300								
<b>n1 max</b> (RPM)	1500 (standard)								
	3500 (special)								

±5%

Upon request, brakes up to size F912 can be equipped with freewheeling clutch.

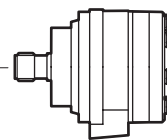
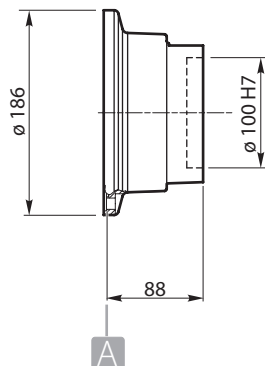
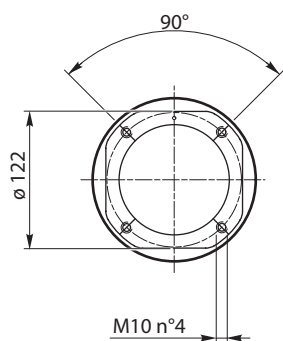
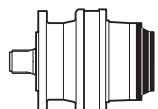

OMRS



		20	30	40	45	
RE 111 - 112 - 113 - 114 RE 211 - 212 - 213 - 214 RE 241 - 242 - 243 - 244 RE 312 - 313 - 314 RE 512 - 513 - 514 RE 613 - 614 RE 813 - 814 RE 1023 - 1024 RE 1523 - 1524 RE 2004 RE 2524 RE 3004 RE 3514-4804 RE 6004L RE 8005 - 8005L GB 12015 - 12015L GB 16005 - 16005L	<b>Tb</b> (Nm)	220	308	396	459	+5%
	<b>pb</b> (bar)	24	24	24	26	
	<b>p max</b> (bar)	150				
	<b>n1 max</b> (RPM)	700				

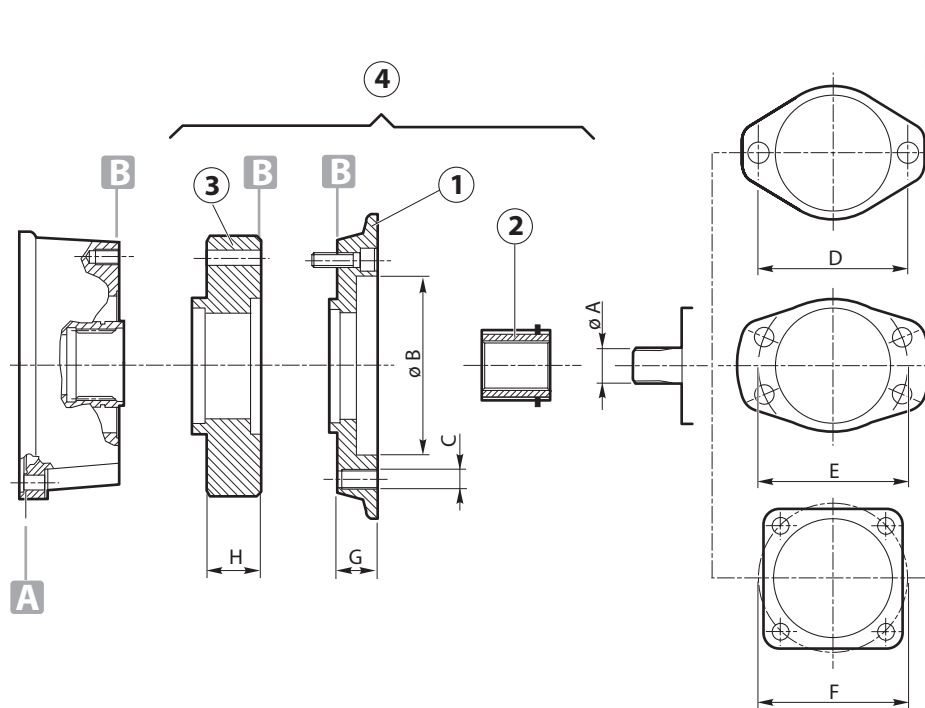

AXIAL PUMP	øA	øB	øC	øD	E	F	G	H	1	2	3	4
M1 15-21	ø 19	82.55	M12	106.4	—	—	26	—	20300047	40000659	—	AQ
M2 24-50	16/32-13	101.6	M14	146	—	—	20	—	40000635	40000657	—	AZ
M2 24-50	16/32-15	101.6	M14	146	—	—	20	—	40000635	40000671	—	BB
M3 40-65	16/32-13	101.6	M14	146	—	—	20	—	40000635	40000657	—	AZ
M3 40-65	16/32-15	101.6	M14	146	—	—	20	—	40000635	40000671	—	BB

DANFOSS	øA	øB	øC	øD	E	F	G	H	1	2	3	4
OMM	ø 16	63	M8	80	—	—	14	—	40000698	40000694	—	CE
OMP 25-400	ø 25	82.55	M12	106.4	—	—	26	—	20300047	40000649	—	AN
OMP 25-400	ø 25.4	82.55	M12	106.4	—	—	26	—	20300047	40000645	—	AI
OMP 25-400	1" B6	82.55	M12	106.4	—	—	26	—	20300047	40000648	—	AM
OMP 25-400	ø 32	82.55	M12	106.4	—	—	38	—	2511001	40000665	—	AD
OMR 50-375	ø 25	82.55	M12	106.4	—	—	26	—	20300047	40000649	—	AN
OMR 50-375	ø 25.4	82.55	M12	106.4	—	—	26	—	20300047	40000645	—	AI
OMR 50-375	1" B6	82.55	M12	106.4	—	—	26	—	20300047	40000648	—	AM
OMR 50-375	ø 32	82.55	M12	106.4	—	—	38	—	02511001	40000665	—	AD
OMH 200-500	ø 32	82.55	M12	106.4	—	—	38	—	02511001	40000665	—	AD
OMH 200-500	12/24-14	82.55	M12	106.4	—	—	38	—	02511001	40000672	—	AE
OMS 80-400	ø 31.75	82.55	M12	106.4	—	—	38	—	02511001	40000664	—	UL
OMS 80-400	ø 32	82.55	M12	106.4	—	—	38	—	02511001	40000665	—	AD
OMS 80-400	12/24-14	82.55	M12	106.4	—	—	38	—	02511001	40000672	—	AE
OMS 80-400 SPEC.	12/24-14	82.55	M10	106.4	—	—	30	—	40000681	40000672	—	CV
OMSS 80-400	12/24-12	100	M10	—	—	125	21	—	02511017	02241030	—	TR
OMTS 160-500	12/24-16	125	M12	160	—	—	42	—	02511081	02241082	—	UR
OMT 160-500	12/24-17	125	M12	—	—	160	86	—	40001833	40000674	—	CI
OMT 160-500	ø 40	125	M12	—	—	160	78	—	02511041	02241051	—	TW
OMT 160-500(US)	12/24-17	127	M12	—	—	150	79.5	—	02511166	40000674	—	DF
OMV 315-800	ø50	160	M16	—	—	200	140	—	02511006	02591003	—	VM
OMVS 315-800	10/20-16	125	M12	—	—	160	66.5	—	02511085	02241086	—	US
MTM	12/24-17	127	M12	—	—	162	29	38	02511108	40000674	02731111	UY

EATON (CHAR-LYNN)	øA	øB	øC	øD	E	F	G	H	1	2	3	4
SERIE 2000	ø 25	82.55	M12	106.4	—	—	26	—	20300047	40000649	—	AN
SERIE 2000	Ø25	82.55	M12		106.4	—	26	—	40000680	40000649	—	BN
SERIE 2000	ø 25.4	82.55	M12	106.4	—	—	26	—	20300047	40000645	—	AI
SERIE 2000	ø 31.75	82.55	M12	106.4	—	—	26	—	20300047	40000664	—	AR
SERIE 2000	ø 32	82.55	M12	106.4	—	—	38	—	2511001	40000665	—	AD
SERIE 2000	1"6B	82.55	M12	106.4	—	—	26	—	20300047	40000648	—	AM
SERIE 2000	12/24-14	82.55	M12	106.4	—	—	26	—	20300047	40000672	—	AU
SERIE 4000	12/24-14	101.6	M12			127	20	—	40000635	40000672	—	EH
SERIE 4000	12/24-17	127	M12	—	—	162	29	—	02511108	40000674	—	BH
SERIE 6000	12/24-17	127	M12	—	—	162	29	14	02511108	02971179	02731096	CQ
SERIE 6000	ø 40	127	M12	—	—	162	29	38	02511108	02241057	02731111	TV
SERIE 6000	8.5/17	127	M12	—	—	162	29	38	02511108	02241076	02731111	UH

HP HYDRAULIC	øA	øB	øC	øD	E	F	G	H	1	2	3	4
M4PV21-28	ø 25.4	101.6	M14	146	—	—	20	—	40000635	40000645	—	AV
M4PV21-28	16/32-13	101.6	M14	146	—	—	20	—	40000635	40000657	—	AZ
M4PV21-28	16/32-15	101.6	M14	146	—	—	20	—	40000635	40000671	—	BB
M4MF 21-28	ø 25.4	82.55	M12	106.4	—	—	26	—	20300047	40000645	—	AI
M4MF 21-28	16/32- 13	82.55	M12	106.4	—	—	26	—	20300047	40000657	—	AP
M4MF 21-28	16/32-15	82.55	M12	106.4	—	—	26	—	20300047	40000671	—	AT
M4PV 34-65	ø 25.4	101.6	M14	146	—	—	20	—	40000635	40000645	—	AV
M4PV 34-65	16/32-13	101.6	M14	146	—	—	20	—	40000635	40000657	—	AZ
M4PV 34-65	16/32-15	101.6	M14	146	—	—	20	—	40000635	40000671	—	BB
M4MF 34-65	ø 25.4	101.6	M14	146	—	—	20	—	40000635	40000645	—	AV
M4MF 34-65	16/32-13	101.6	M14	146	—	—	20	—	40000635	40000657	—	AZ
M4MF 34-65	16/32-15	101.6	M14	146	—	—	20	—	40000635	40000671	—	BB
M4MV 34-65	ø 25.4	101.6	M14	146	—	—	20	—	40000635	40000645	—	AV
M4MV 34-65	16/32-13	101.6	M14	146	—	—	20	—	40000635	40000657	—	AZ
M4MV 34-65	16/32-15	101.6	M14	146	—	—	20	—	40000635	40000671	—	BB

LINDE	øA	øB	øC	øD	E	F	G	H	1	2	3	4
HMF 35	16/32-15	101.6	M14	146	—	—	20	—	40000635	40000671	—	BB
HMF 50-75	16/32-21	127	M16	181	—	—	34	—	02511108	40000654	—	CF
HMF 105	16/32-23	127	M16	181	—	—	34	—	40001811	40000686	—	CH
HMF 135	16/32-27	152.4	M20	228.5	—	—	35	—	40001844	02241123	—	CZ
HMR 135	16/32-27	152.4	M20	228.5	—	—	35	—	40001844	02241123	—	CZ
BPV 70	W35x2	127	M12	162	—	—	25	—	02511108	40000670	—	VK

M + S	øA	øB	øC	øD	E	F	G	H	1	2	3	4
EPMM 8-50	ø 14	63	M8	80	—	—	14	—	40000698	40000658	—	CD
EPM M 8-50	ø 16	63	M8	80	—	—	14	—	40000698	40000694	—	CE
EPM 40-630	ø 25	82.55	M12	106.4	—	—	26	—	20300047	40000649	—	AN
EPM 40-630	ø 25.4	82.55	M12	106.4	—	—	26	—	20300047	40000645	—	AI
EPM 40-630	1" 6B	82.55	M12	106.4	—	—	26	—	20300047	40000648	—	AM
EPM 40-630	25/22-14	82.55	M12	106.4	—	—	26	—	20300047	40000647	—	AL
EPM 40-630	12/24-14	82.55	M12	106.4	—	—	38	—	2511001	40000672	—	AE
EPM 40-630	ø 32	82.55	M12	106.4	—	—	38	—	2511001	40000665	—	AD
EPRM 50-400	ø 25	82.55	M12	106.4	—	—	26	—	20300047	40000649	—	AN
EPRM 50-400	ø 25.4	82.55	M12	106.4	—	—	26	—	20300047	40000645	—	AI
EPRM 50-400	1" 6B	82.55	M12	106.4	—	—	26	—	20300047	40000648	—	AM
EPRM 50-400	25/22-14	82.55	M12	106.4	—	—	26	—	20300047	40000647	—	AL
EPRM 50-400	12/24-14	82.55	M12	106.4	—	—	38	—	02511001	40000672	—	AE
EPRM 50-400	ø 32	82.55	M12	106.4	—	—	38	—	02511001	40000665	—	AD
EPMS 80-400	ø 31.75	82.55	M12	106.4	—	—	38	—	02511001	40000664	—	AC
EPMS 80-400	ø 32	82.55	M12	106.4	—	—	38	—	02511001	40000665	—	AD
EPMS 80-400	12/24-17	82.55	M12	106.4	—	—	38	—	02511001	40000674	—	AF
EPMT 160-500	12/24-17	125	M12	—	—	160	86	—	40001833	40000674	—	CI
MTS 250	12/24-16	125	M12	160	—	—	42	—	02511081	02241082	—	UR

REXROTH	øA	øB	øC	øD	E	F	G	H	1	2	3	4
A2FE 45	W30x2	160	M16	200			107.5		02511250	40000669		ER
A2FE 56	W30x2	160	M16	200			107.5		02511250	40000669		ER
A2FE 80	W35x3	190	M20	224			133		02511281	40000670		ES
A2FM 10-16	ø 25	80	M8	—	—	100	36.5	—	40001842	40000649	—	CL
A2FM 10-16	W25x1.25	80	M8	—	—	100	36.5	—	40001842	40000668	—	CM
A2FM 23-32	ø 25	100	M10	—	—	125	48	—	40000682	40000649	—	BS
A2FM 23-32	W25X1.25	100	M10	—	—	125	48	—	40000682	40000668	—	BT
A2FM 23-32	W30x2	100	M10	—	—	125	48	—	40000682	40000669	—	BU
A2FM 45-63	W30x2	125	M12	—	—	160	44	—	40000684	40000669	—	CA
A2FM 45-63	W35x2	125	M12	—	—	160	44	—	40000684	40000670	—	CB
A2FM 80-90	W35x2	140	M12	—	—	180	53	—	40001852	40000670	—	CN
A2FM 80-90	W40x2	140	M12	—	—	180	53	—	40001852	40001858	—	CP
A2FM 107	W40x2	160	M16	—	—	200	56.5	—	02511039	40001858	—	TP
A2FM 125	W40x2	160	M16	—	—	200	56.5	—	02511039	40001858	—	TP
A2FM 160	W50x2	180	M16	—	—	224	62	—	02511109	02591102	—	CT
A2FM 200	W50x2	200	M20	—	—	250	73	—	02511232	02591102	—	DB
A4FM 22-28	16/32-13	101.6	M14	146	—	—	20	—	40000635	40000657	—	AZ
A4FM 22-28	16/32-15	101.6	M14	146	—	—	20	—	40000635	40000671	—	BB
A4FM 40	W30x2	101.6	M14	146	—	—	20	—	40000635	40000669	—	BA
A4FM 56	W30x2	127	M16	181	—	—	34	—	40001811	40000669	—	CG
A10FM 23-28	16/32-13	101.6	M14	146	—	—	20	—	40000635	40000657	—	AZ
A10FM 37-45	16/32-15	101.6	M14	146	—	—	20	—	40000635	40000671	—	BB
A6VM 28	W25x1.25	100	M10	—	—	125	48	—	40000682	40000668	—	BT
A6VM 28	W30x2	100	M10	—	—	125	48	—	40000682	40000669	—	BU
A6VM 55	W30x2	125	M12	—	—	160	44	—	40000684	40000669	—	CA
A6VM 55	W35x2	125	M12	—	—	160	44	—	40000684	40000670	—	CB
A6VM 80	W35x2	140	M12	—	—	180	53	—	40001818	40000670	—	CN
A6VM 80	W40x2	140	M12	—	—	180	53	—	40001818	40001858	—	CP
A6VM 107	W45x2	160	M16	—	—	200	56.5	—	02511039	02591073	—	VN
A6VM 140	W45x2	180	M16	—	—	224	62	—	02511109	02591073	—	VQ
A6VM 160	W45x2	180	M16	—	—	224	62	—	02511109	02591073	—	VQ
A6VM 160	W50x2	180	M16	—	—	224	62	—	02511109	02591102	—	CT
A6VM 250	W50x2	200	M20	—	—	250	73	—	02511232	02591102	—	DB
AA6VM 55, 80	12/24-12	127	M14	—	—	162	29	—	02511108	40000672	—	BG
AA6VM 107, 160	8/16-13	152.4	M20	—	—	228.5	41	—	40001844	02241043	—	UX
AA2FM 10, 12, 16	16/32-13	101.6	M14	146	—	—	20	—	40000635	40000657	—	AZ
AA2FM 23, 28, 32	12/24-12	127	M12	—	—	—	29	—	02511108	40000672	—	BG
AA2FM 45, 56, 63	12/24-12	127	M12	—	—	162	29	—	02511108	40000672	—	BG
AA2FM 80, 90	12/24-12	127	M12	—	—	162	29	—	02511108	40000672	—	BG
AA2FM 56, 63	16/32-21	127	M12	—	—	162	29	—	02511108	40000654	—	BD
AA2FM 80, 90	16/32-21	127	M12	—	—	162	29	—	02511108	40000654	—	BD
AA2FM 107, 125	8/16-13	152.4	M20	—	—	228.5	41	—	40001844	02241043	—	UX
AA2FM 160, 180	8/16-13	152.4	M20	—	—	228.5	41	—	40001844	02241043	—	UX

SAE STANDARD	øA	øB	øC	øD	E	F	G	H	1	2	3	4
SAE A	ø 25	82.55	M12	106.4	—	—	26	—	20300047	40000649	—	—
	ø 25.4	82.55	M12	106.4	—	—	26	—	20300047	40000645	—	—
	ø 31.75	82.55	M12	106.4	—	—	26	—	20300047	40000664	—	—
	ø 32	82.55	M12	106.4	—	—	26	—	20300047	40000665	—	—
	1"6B	82.55	M12	106.4	—	—	26	—	20300047	40000648	—	—
	12/24-14	82.55	M12	106.4	—	—	26	—	20300047	40000672	—	—
SAE B	ø 25	101.6	M14	146	—	—	20	—	40000635	40000649	—	—
	ø 25.4	101.6	M14	148	—	—	20	—	40000635	40000645	—	—
	ø 31.75	101.6	M14	146	—	—	20	—	40000635	40000664	—	—
	ø 32	101.6	M14	146	—	—	20	—	40000635	40000665	—	—
	1" 6B	101.6	M14	146	—	—	20	—	40000635	40000648	—	—
	12/24-14	101.6	M14	146	—	—	20	—	40000635	40000672	—	—

SAE STANDARD	øA	øB	øC	øD	E	F	G	H	1	2	3	4
<b>MAGNETO</b>	ø 25	82.55	M12	—	106.4	—	26	—	40000680	40000649	—	—
	ø 25.4	82.55	M12	—	106.4	—	26	—	40000680	40000645	—	—
	ø 31.75	82.55	M12	—	106.4	—	26	—	40000680	40000664	—	—
	ø 32	82.55	M12	—	106.4	—	26	—	40000680	40000665	—	—
	1" 6B	82.55	M12	—	106.4	—	26	—	40000680	40000648	—	—
12/24-14	82.55	M12	—	106.4	—	26	—	40000680	40000672	—	—	
<b>SAE C</b>	ø 31.75	127	M12	—	—	162	29	—	02511108	40000664	—	—
	12/24-14	127	M12	—	—	162	29	—	02511108	40000672	—	—
	12/24-17	127	M12	—	—	162	29	—	02511108	40000674	—	—

SAMHYDRAULIK	øA	øB	øC	øD	E	F	G	H	1	2	3	4
<b>BGM 13-50</b>	ø16	63	M8	80	—	—	14	—	40000698	40000694	—	CE
<b>BG 40-400</b>	ø25	82.55	M12	106.4	—	—	26	—	20300047	40000649	—	AN
<b>BG 40-400</b>	ø25.4	82.55	M12	106.4	—	—	26	—	20300047	40000645	—	AI
<b>BG 40-400</b>	1" 6B	82.55	M12	106.4	—	—	26	—	20300047	40000648	—	AM
<b>AGF 50-400</b>	ø25	82.55	M12	106.4	—	—	26	—	20300047	40000649	—	AN
<b>ARF 50-400</b>	ø25	82.55	M12	106.4	—	—	26	—	20300047	40000649	—	AN
<b>BR 50-400</b>	ø25	82.55	M12	106.4	—	—	26	—	20300047	40000649	—	AN
<b>BR 50-400</b>	ø25.4	82.55	M12	106.4	—	—	26	—	20300047	40000645	—	AI
<b>BR 50-400</b>	ø31.75	82.55	M12	106.4	—	—	26	—	20300047	40000664	—	AR
<b>BR 50-400</b>	ø 32	82.55	M12	106.4	—	—	38	—	20300047	40000665	—	AS
<b>BR 50-400</b>	1" 6B	82.55	M12	106.4	—	—	26	—	20300047	40000648	—	AM
<b>H1C 12</b>	Ø20	80	M8	—	—	100	36.5	—	02971201	02591008	—	CS
<b>H1C 30</b>	W25x1,25	100	M10	—	—	125	31	—	02511221	40000668	—	DW
<b>H1C 55</b>	12/24-17	127	M14	—	—	162	29	—	40000653	40000672	—	UT
<b>H1C 55</b>	W30x2	125	M12	—	—	160	44	—	40000684	40000669	—	CA
<b>H1C 55</b>	Ø30	125	M12	—	—	160	44	—	40000684	02591040	—	DU
<b>H1C 75</b>	W35x2	140	M12	—	—	180	53	—	40001818	40000670	—	TQ
<b>H1C 90-108</b>	W40x2	160	M16	—	—	200	57	—	02511039	40001858	—	TP
<b>H1C 90-108</b>	Ø40	160	M16	—	—	200	56.5	—	02511039	02241057	—	EF
<b>H1C 160</b>	W45x2	180	M16	—	—	224	62	—	02511109	02591073	—	VQ
<b>HPR 80-400</b>	ø31.75	82.55	M12	106.4	—	—	38	—	02511001	40000664	—	AC
<b>HPR 80-400</b>	ø 32	82.55	M12	106.4	—	—	38	—	02511001	40000665	—	AD
<b>HPR 80-400</b>	12/24-14	82.55	M12	106.4	—	—	38	—	02511001	40000672	—	AE
<b>H2V 55</b>	W30x2	125	M12	—	—	160	44	—	40000684	40000669	—	CA
<b>H2V 160</b>	W45x2	180	M16	—	—	224	62	—	02511109	02591073	—	VQ

SAUER	øA	øB	øC	øD	E	F	G	H	1	2	3	4
<b>SMF2 033-070</b>	16/32-21	127	M12	—	—	162	29	—	02511108	40000654	—	BD
<b>SMF2 089</b>	16/32-23	127	M14	—	—	162	29	—	40000653	40000686	—	BI
<b>M25MF</b>	16/32-13	101.6	M14	146	—	—	20	—	40000635	40000657	—	AZ
<b>M35MF</b>	16/32-13	101.6	M14	146	—	—	20	—	40000635	40000657	—	AZ
<b>M35/M44 MF</b>	16/32-15	101.6	M14	146	—	—	20	—	40000635	40000671	—	BB
<b>M44MF</b>	16/32-13	101.6	M14	146	—	—	20	—	40000635	40000657	—	AZ
<b>M46MF</b>	16/32-13	101.6	M14	146	—	—	20	—	40000635	40000657	—	AZ
<b>51D 80</b>	W40x2	140	M12	—	—	180	53	—	40001818	40001858	—	CP
<b>51D 110</b>	W40x3	160	M16	—	—	200	56.5	—	02511039	40001858	—	TP
<b>51V 080</b>	12/24-14	127	M12	—	—	162	29	—	02511108	40000672	—	BG
<b>51V 080</b>	16/32-23	127	M12	—	—	162	29	—	02511108	40000686	—	BI
<b>51V 110/160A</b>	8/16-13	152.4	M20	—	—	228.5	40	—	02511164	02631152	—	8X
<b>51V 160/A</b>	8/16-13	152.4	M20	—	—	228.5	40	—	40001844	02241043	—	UX
<b>51V 250</b>	16/32-27	161.5	M20	—	—	317.15	35	—	02511147	02241123	—	EJ
<b>90M 030</b>	16/32-13	101.6	M14	146	—	—	20	—	40000635	40000657	—	AZ
<b>90M 030</b>	16/32-15	101.6	M14	146	—	—	20	—	40000635	40000671	—	BB
<b>90M 042</b>	16/32-13	101.6	M14	146	—	—	20	—	40000635	40000657	—	AZ
<b>90M 042</b>	16/32-15	101.6	M14	146	—	—	20	—	40000635	40000671	—	BB
<b>90M 055</b>	16/32-21	127	M12	—	—	162	29	—	02511108	40000654	—	BD
<b>90M 075</b>	16/32-21	127	M12	—	—	162	29	—	02511108	40000654	—	BD
<b>90M 100</b>	16/32-23	127	M12	—	—	162	29	—	02511108	40000686	—	BI
<b>90M 100</b>	8/16-13	127	M12	—	—	162	29	—	02511108	02241013	—	EV
<b>90M 130</b>	8/16-Z13	152.4	M20	—	—	228.5	40	—	40001844	022411043	—	UX

VOAC	øA	øB	øC	øD	E	F	G	H	1	2	3	4
F11-150 SAE	8/16-13	152.4	M20	228.5	—	—	41	—	40001844	02241043	—	UX
F12-30 SAE	ø25.4	101.6	M14	146	—	—	20	—	40000635	40000645	—	AV
F12-30 SAE	16/32-13	101.6	M14	146	—	—	20	—	40000635	40000657	—	AZ
F12-40 SAE	ø31.75	127	M12	—	—	162	29	—	02511108	40000664	—	BF
F12-40 SAE	12/24-14	127	M12	—	—	162	29	—	02511108	40000672	—	BG
F12-60 SAE	ø31.75	127	M12	—	—	162	29	—	02511108	40000664	—	BF
F12-60 SAE	12/24-14	127	M12	—	—	162	29	—	02511108	40000672	—	BG
F12-80 SAE	12/24-17	127	M12	—	—	162	29	—	02511108	40000674	—	BH
V12-60 SAE	12/24-14	127	M12	—	—	162	29	—	02511108	40000672	—	BG
V12-80 SAE	12/24-14	127	M12	—	—	162	29	—	02511108	40000672	—	BG
F12-110 SAE	8/16-13	152.4	M20	228.5	—	—	41	—	40001844	02241043	—	UX
V14-160 ISO	W45x2	180	M16	224	—	—	62	—	02511109	02591073	—	VQ
F12-80 ISO	ø40	140	M12	—	—	180	53	38	40001852	02241057	27311111	UW
TK	12/24-17	127	M12	—	—	162	29	14	02511108	40000674	2731096	CQ
F12-30 ISO	W30x2	100	M10	—	—	125	48	—	40000682	40000669	—	BU
F12-40 MF-HI ISO	W30x2	125	M12	160	—	—	44	—	40000684	40000669	—	CA
F12-60 ISO	W35x2	125	M12	—	—	160	44	—	40000684	40000670	—	CB
F12-80 ISO	W40x2	140	M12	—	—	180	53	—	40001852	40001858	—	CP
F12-110 ISO	W45x2	160	M16	200	—	—	56.5	—	02511039	02591073	—	VN

WHITE	øA	øB	øC	øD	E	F	G	H	1	2	3	4
RS 03-24	ø25	82.55	M12	106.4	—	—	26	—	20300047	40000649	—	AN
RS 03-24	ø25.4	82.55	M12	106.4	—	—	26	—	20300047	40000645	—	AI
RS 03-24	1" 6B	82.55	M12	106.4	—	—	26	—	20300047	40000648	—	AM
HB 03-24	ø25	82.55	M12	106.4	—	—	26	—	20300047	40000649	—	AN
HB 03-24	ø25.4	82.55	M12	106.4	—	—	26	—	20300047	40000645	—	AI
HB 03-24	ø31.75	82.55	M12	106.4	—	—	26	—	20300047	40000664	—	AR
HB 03-24	ø32	82.55	M12	106.4	—	—	26	—	20300047	40000665	—	AS
HB 03-24	1" 6B	82.55	M12	106.4	—	—	26	—	20300047	40000648	—	AM
HB 03-24	12/24-14	82.55	M12	106.4	—	—	26	—	20300047	40000672	—	AU
HB 03-24	16/32-13	82.55	M12	106.4	—	—	26	—	20300047	40000657	—	AP
RE 07-45	ø25	82.55	M12	—	106.4	—	26	—	40000680	40000649	—	BN
RE 07-45	ø25.4	82.55	M12	—	106.4	—	26	—	40000680	40000645	—	BL
RE 07-45	ø31.75	82.55	M12	—	106.4	—	26	—	40000680	40000664	—	BP
RE 07-45	ø32	82.55	M12	—	106.4	—	26	—	40000680	40000665	—	BQ
RE 07-45	1" 6B	82.55	M12	—	106.4	—	26	—	40000680	40000648	—	BM
RE 07-45	12/24-14	82.55	M12	—	106.4	—	26	—	40000680	40000672	—	BR
DR 12-46	ø25	82.55	M12	—	106.4	—	26	—	40000680	40000649	—	BN
DR 12-46	ø25.4	82.55	M12	—	106.4	—	26	—	40000680	40000645	—	BL
DR 12-46	ø31.75	82.55	M12	—	106.4	—	26	—	40000680	40000664	—	BP
DR 12-46	ø32	82.55	M12	—	106.4	—	26	—	40000680	40000665	—	BQ
DR 12-46	1" 6B	82.55	M12	—	106.4	—	26	—	40000680	40000648	—	BM
DR 12-46	12/24-14	82.55	M12	—	106.4	—	26	—	40000680	40000672	—	BR

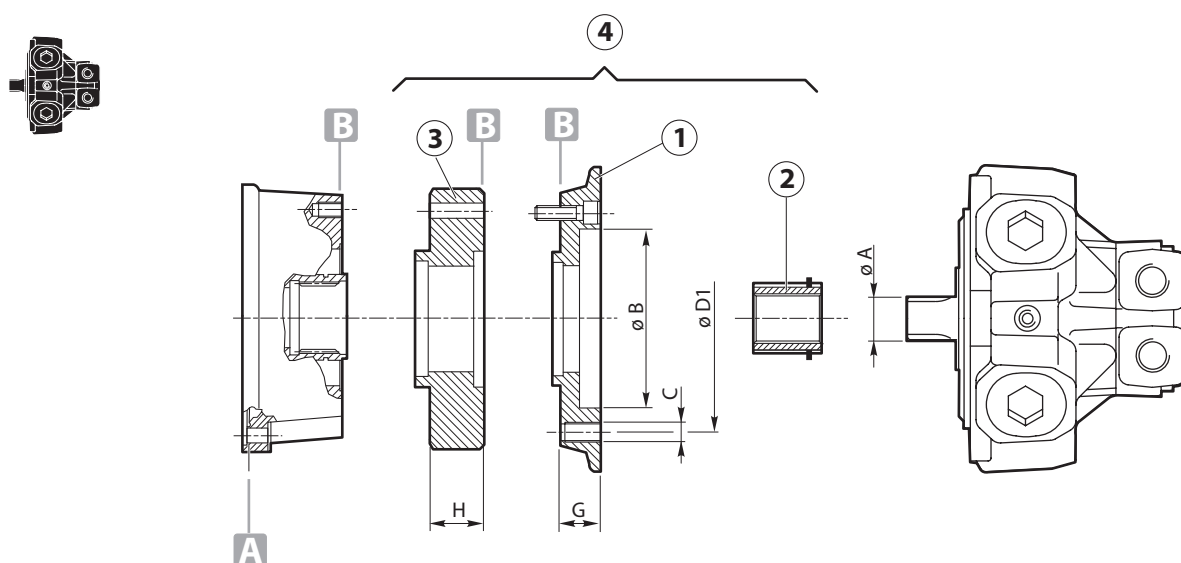

INTERMOT	øA	øB	C	øD1	E	F	G	H	1	2	3	4
G34/A-AA	ø30	82.55	M12	106.4	—	—	10.5	26	02511082	2591040	02511018	UM
G 100	W40x2	125	M8	175	—	—	44	—	02511282	40001858	—	EQ
G 100	A40x36	125	M8	175	—	—	44	—	02511282	40001858	—	ET
IAM 195	6x26x32	172	M10	190	—	—	39.5	—	02511170	40001829	—	DE

SAI	øA	øB	C	øD1	E	F	G	H	1	2	3	4
BD2	W40x2	150	M12	250	—	—	38	—	02511070	02591049	—	UE
BV2	W40x2	150	M12	250	—	—	38	—	02511070	02591049	—	UE
GM05 40-200	28x34x6	125	M10	160	—	—	40	—	02511045	40000646	—	TZ
GM05 40-200	35x2x16	125	M10	160	—	—	40	—	02511045	40000670	—	TT
GM05 40-200	ø30	125	M10	160	—	—	40	—	02511045	02591040	—	TM
GM1 100-320	28x34x6	175	M12	210	—	—	29	—	02971466	40000646	—	VB
GM1 100-320	35x2x16	175	M12	210	—	—	29	—	02971466	40000670	—	TJ
GM2 200-630	40x3x12	150	M12	250	—	—	38	—	02511070	02591044	—	UB
GM2 200-630	36x40	150	M12	250	—	—	38	—	02511070	02591063	—	VA
GM3	W40x3	265	M18	310	—	—	43.5	—	02511151	02591044	—	DS

CALZONI	øA	øB	øC	øD1	E	F	G	H	1	2	3	4
MR 250-300	42x48x8	175	M10	232	—	—	92	—	02511030	02591016	—	FA

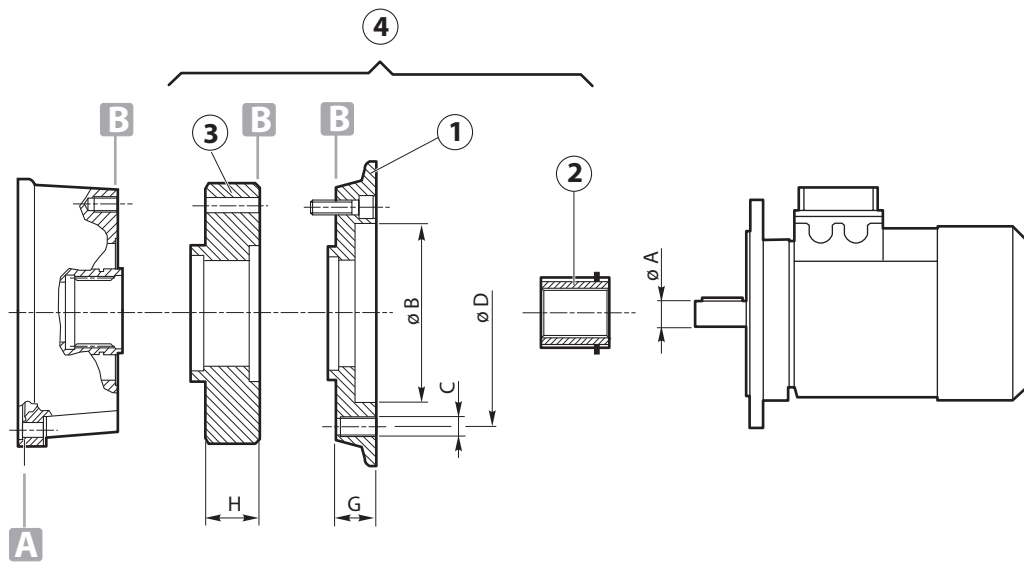

IEC	øA	øB	C	øD	E	F	G	H	1	2	3	4
<b>63 B5</b>	ø11	95	M8	115	—	—	20	—	02511000	02591001	—	TL
<b>71 B5</b>	ø14	110	M8	130	—	—	16	—	40000690	40000658	—	CC
<b>80 B5</b>	ø19	130	M10	165	—	—	16	—	40000683	40000659	—	BV
<b>90 B5</b>	ø24	130	M10	165	—	—	16	—	40000683	40000660	—	BZ
<b>100 B5 ø24</b>	ø24	180	M12	215	—	—	16	—	02511018	40000660	—	UÀ
<b>100/112 B5</b>	ø28	180	M12	215	—	—	24.5	—	02511018	40000661	—	AH
<b>112 B5</b>	ø38	180	M12	215	—	—	24	38	02511018	02241029	02731111	UU
<b>132 B5</b>	ø38	230	M12	265	—	—	49	—	02511016	—	—	AG
<b>132 B14</b>	ø38	130	ø 11	165	—	—	69	—	02511076	—	—	UF
<b>200 B5</b>	ø55	300	M18	350	—	—	130	—	02511067	02241066	—	TX

NEMA	øA	øB	C	øD	E	F	G	H	1	2	3	4
<b>56 H</b>	ø15.88 (0.625)	114.3 (4.500)	Ø10 (0.394)	149.2 (5.874)	—	—	53 (2.087)	—	02511122	02591085	—	VX
<b>143-145 TC</b>	ø22.22 (0.875)	114.3 (4.500)	Ø10 (0.394)	149.2 (5.874)	—	—	53 (2.087)	—	02511122	02591084	—	VZ
<b>182-184 TC</b>	ø28.57 (1.125)	215.9 (8.500)	Ø14 (0.551)	206 (8.110)	—	—	38 (1.496)	—	02511073	02591045	—	UC
<b>213-215 TC</b>	ø34.925 (1.375)	215.9 (8.500)	Ø14 (0.551)	184.5 (7.264)	—	—	55.5 (2.185)	—	02511037	02241048	—	VT
<b>254-256 TC</b>	ø41.275 (1.625)	215.9 (8.500)	Ø14 (0.551)	150 (5.906)	—	—	70 (2.756)	—	02511141	02241131	—	VJ
<b>284-286 TC</b>	ø47.625 (1.875)	266.7 (10.500)	Ø14 (0.551)	228.6 (9.000)	—	—	86 (3.386)	—	02511142	02241132	—	CR

mm (inch)

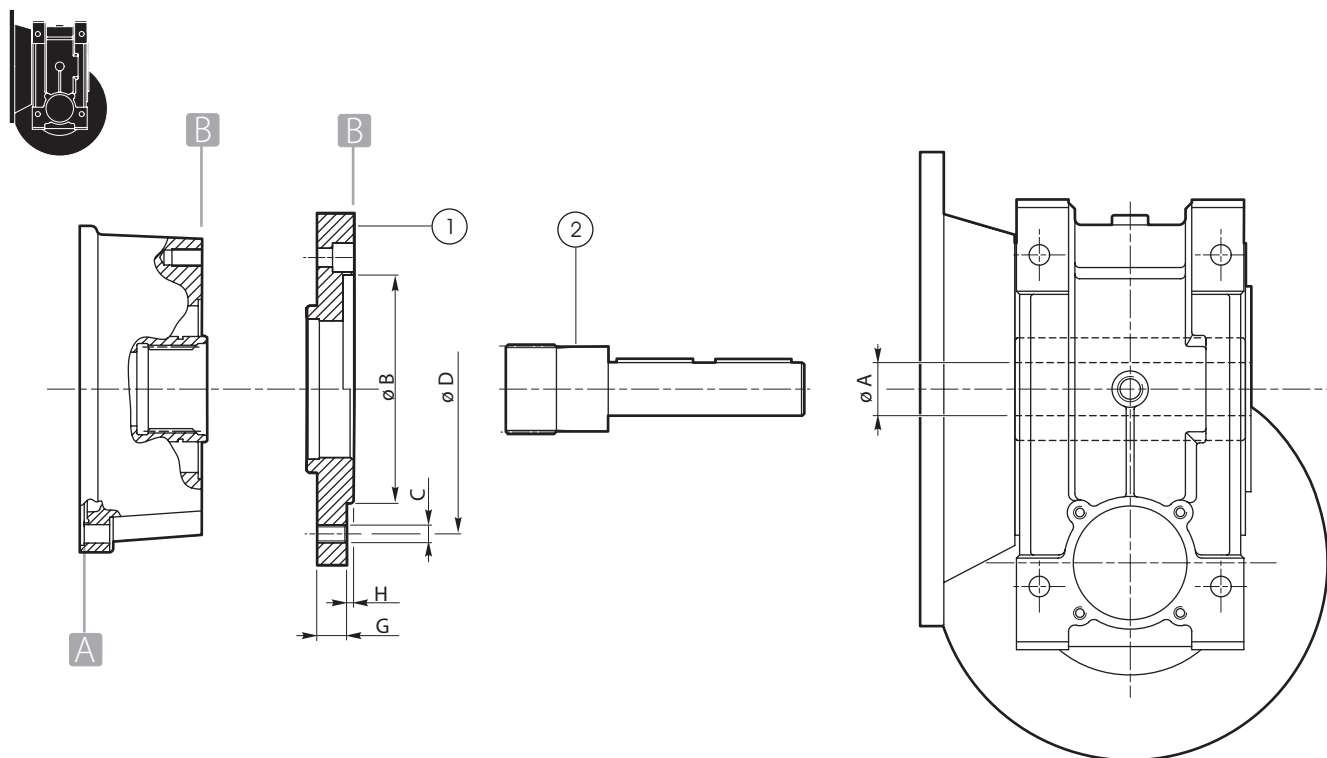

VARVEL	ØA	ØB	ØC	ØD	E	F	G	H	1	2	3	4
FRS 50 FL	Ø24	110	M10	130	—	—	16	—	02511022	40000660	—	VR
FRS 60 FL	Ø25	115	M10	150	—	—	16	—	02511095	40000649	—	UZ
FRS 70 FL	Ø28	130	M12	165	—	—	13.5	—	40000644	40000650	—	TI
FRS 85 FL	Ø32	130	M12	165	—	—	13.5	—	40000644	40000655	—	TG
FRS 130 PC	Ø48	180	Ø13	215	—	—	20	—	40001804	40000652	—	VI

STM	ØA	ØB	ØC	ØD	E	F	G	H	1	2	3	4
RMI 50 FL	Ø24	110	M10	130	—	—	16	—	02511022	40000660	—	VR
RMI 60 FL	Ø25	115	M10	150	—	—	16	—	02511095	40000649	—	UZ
RMI 70 FL	Ø28	130	M12	165	—	—	13.5	—	40000644	40000650	—	TI
RMI 85 FL	Ø32	130	M12	165	—	—	13.5	—	40000644	40000655	—	TG
RMI 110 F1	Ø42	130	M10	165	—	—	17	—	40001810	40001809	—	VH
RMI 130 P	Ø48	180	Ø13	215	—	—	20	—	40001804	40000652	—	VI
RMI 150 P	Ø55	180	Ø13	215	—	—	20	—	40001804	40001808	—	EN

MOTOVARIO	ØA	ØB	ØC	ØD	E	F	G	H	1	2	3	4
NMRV 110	Ø42	180	M12	215	—	—	24.5	—	02511018	40001890	—	FE
NMRV 90	Ø35	130	M10	165	—	—	17	4	40001810	02591038	—	UQ

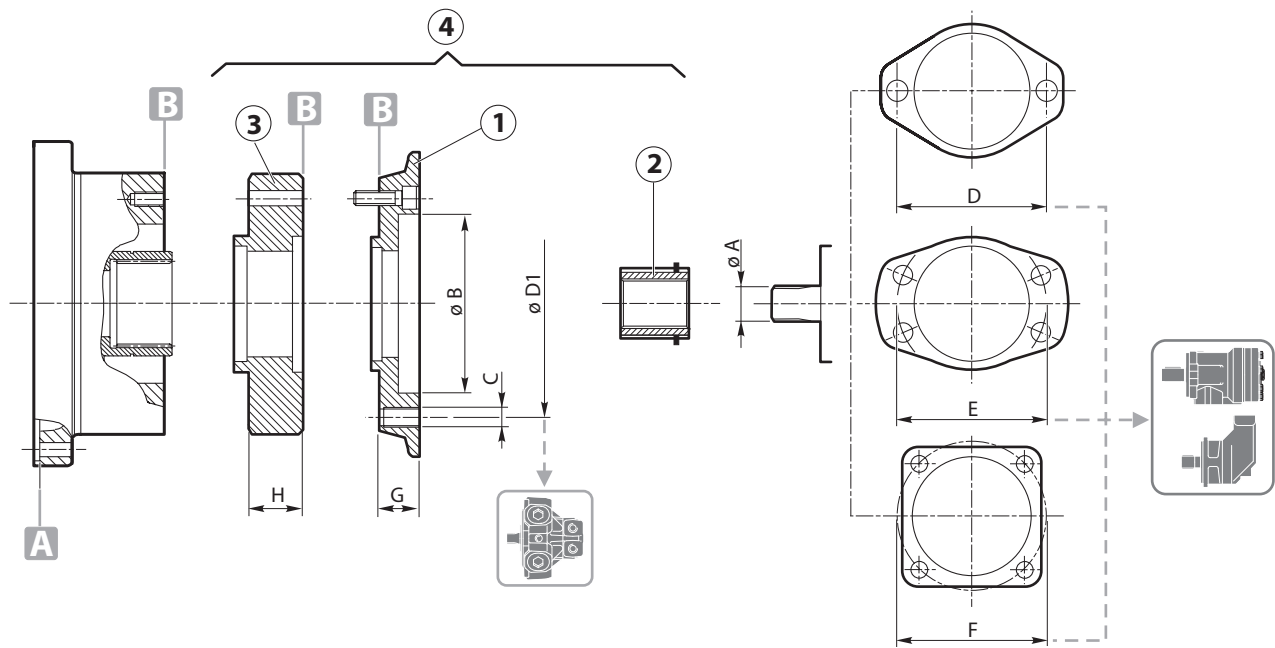

CALZONI	A	ØB	ØC	ØD1	E	F	G	H	1	2	3	4
MR700	8x52x60	220	M12	290	—	—	55.5	—	02511229	02591156	—	4J

DANFOSS	A	ØB	ØC	ØD	E	F	G	H	1	2	3	4
OMV	16/32-16	160	M16	—	—	200	73	—	025110102	025910102	—	5U
OMT 160-500	12/24-17	125	M12	—	—	160	66.5	—	025110117	02591123	—	3I
OMT 160-500	Ø40	125	M12	—	—	160	66.5	—	025110117	025910109	—	7W

EATON	A	ØB	ØC	ØD	E	F	G	H	1	2	3	4
SERIE 6000	12/24-17	127	M14	—	—	162	29	—	02511192	02591123	—	3Q
SERIE 6000	12/24-14	127	M12	—	—	162	37	—	02511192	02591163	—	2G

INTERMOT	A	ØB	ØC	ØD1	E	F	G	H	1	2	3	4
IAM H3 400-700	36x42x8	230	M14	254	—	—	43	—	02511197	02591128	—	8I
IAM300	8x32x38	190	M12	210	—	—	38.5	—	02511248	02591166	—	4N

LINDE	A	ØB	ØC	ØD	E	F	G	H	1	2	3	4
HMF 135	16/32-27	152.4	M20	228.5	—	—	35	—	02511164	02631166	—	3Z
HMR 135	16/32-27	152.4	M20	228.5	—	—	35	—	02511164	02631166	—	3Z
HMF 105	16/32-23	127	M16	181	—	—	34	—	02511192	02631203	—	3H

M+S	A	ØB	ØC	ØD	E	F	G	H	1	2	3	4
EPMT 160-500	12/24-17	125	M12	—	—	160	66.5	—	025110117	02591123	—	3I
EPMT 160-500	Ø40	125	M12	—	—	160	66.5	—	025110117	025910109	—	7W

REXROTH	A	ØB	ØC	ØD	E	F	G	H	1	2	3	4
A2FM 107	W40x2	160	M16	—	—	200	51.5	—	02511230	02631193	—	3U
A2FM 160	W50x2	180	M16	—	—	224	62	—	02511163	02631150	—	3T
A2FM 200	W50x2	200	M20	—	—	250	73	—	02511165	02631150	—	4B
A6VM 107	W45x2	160	M16	—	—	200	53	—	02511167	02631160	—	9N
A6VM 160	W45x2	180	M16	—	—	224	62	—	02511163	02631151	—	9Q
A6VM 160	W50x2	180	M16	—	—	224	62	—	02511163	02631150	—	3T
A6VM 250	W50x2	200	M 20	—	—	250	73	—	02511165	02631150	—	4B
A6VM 355	W60x2	280	M16	—	—	320	84.5	—	02511261	02631210	—	5L
AA6VM 107, 160	8/16-13	152.4	M20	—	—	228.5	40	—	02511164	02631152	—	8X
AA2FM 107, 125	8/16-13	152.4	M20	—	—	228.5	40	—	02511164	02631152	—	8X
AA2FM 160, 180	8/16-13	152.4	M20	—	—	228.5	40	—	02511164	02631152	—	8X

SAI	A	øB	øC	øD	E	F	G	H	1	2	3	4
GM1	28x34x6	175	M12	210	—	—	29	—	02511263	02591176	—	6B
GM2	36x40	150	M12	250	—	—	38	—	02511209	02591141	—	9A
GM2	W40x3	150	M12	250	—	—	38	—	02511209	02591170	—	8B
GM3	W40x3	265	M18	310	—	—	43.5	—	02511151	02591044	—	4S

SAMHYDRAULIK	A	øB	øC	øD	E	F	G	H	1	2	3	4
H1C 160 M	W45x2	180	M16	—	—	224	62	—	02511039	02631151	—	9Q
H1C 226 M	W50x2	200	M20	—	—	250	73	—	02511165	02631150	—	4B
H2V 160 M	W45x2	180	M16	—	—	224	62	—	02511163	02631151	—	9Q

SAUER	A	øB	øC	øD	E	F	G	H	1	2	3	4
51V250	16/32-27	165.1	M20	—	—	317.5	38	—	02511201	02631166	—	5J
90M 130	8/16-13	152.4	M 20	—	—	228.5	40	—	02511164	02631152	—	8X

VOAC	A	øB	øC	øD	E	F	G	H	1	2	3	4
F11-50 CETOP	W45x2	200	M20	250	—	—	73	—	02511165	02631151	—	5P
F11-150 SAE	8/16-13	152.4	M20	—	—	228.5	40	—	02511164	02631152	—	8X
F12-110 SAE	8/16-13	152.4	M20	—	—	228.5	40	—	02511164	02631152	—	8X
V14-160 ISO	W45x2	180	M16	—	—	224	62	—	02511163	02631151	—	9Q
F12-110 ISO	W45x2	160	M116	—	—	200	53	—	02511167	02631160	—	9N

### Direct motor adapters available for:

KAWASAKY	Shaft
KAWASAKY HMC 80	6/12-14
KAWASAKY HMC/HMB/HPC 125	6/12-20
KAWASAKY HMB 200	6/12 -14
KAWASAKY HMB 200	W85x3

SAI	Shaft
GM3	W40x3
GM3	8x46x54
GM4/5	8x56x65
GM4/5	W65x3
GM6	N80x3

POCLAIN	Shaft
MS08/MSE08	W70x3
MS18/MSE18	W90x3
MS18/MSE18	NF E-22 141 (m2.5 z34)
MS50	NF E-22 141 (m3.75 z33)
MS02/MSE02	W50x2

POCLAIN HYDROBASE	Shaft
MS18/MSE18	NF E-22 141 (m2.5 z34)
MS35	NF E-22 141 (m2.5 z34)
MS50	NF E-22 141 (m2.5 z38)

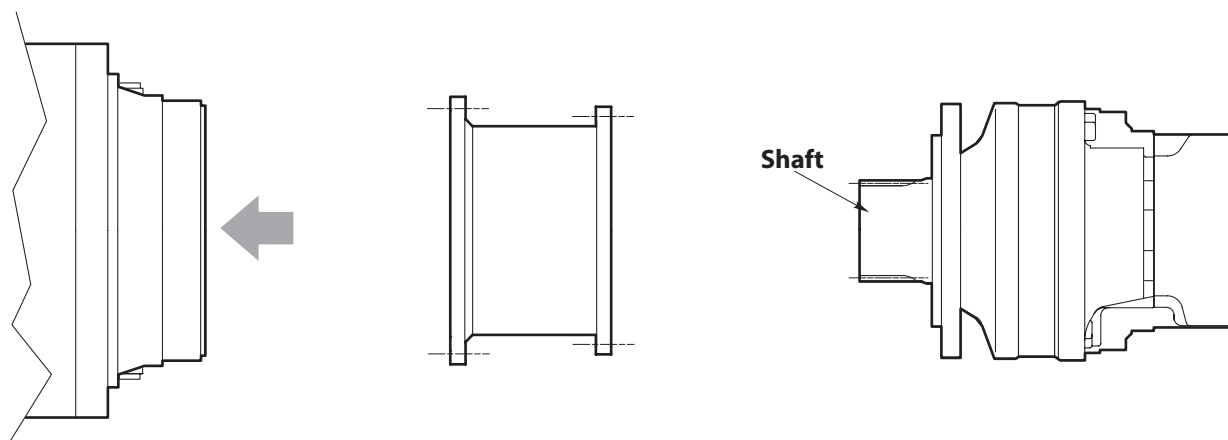

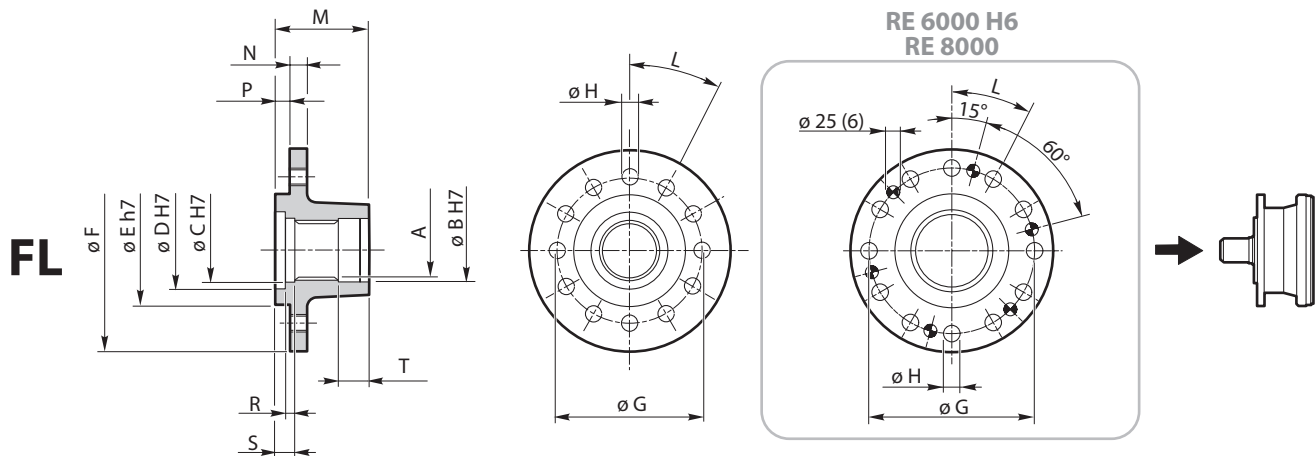

	VERSION	A	$\varnothing B$	$\varnothing C$	$\varnothing D$	$\varnothing E$	$\varnothing F$	$\varnothing G$	$\varnothing H$	L
RE 110-210	N-P-T-TR	A40x36 DIN 5482	42	42	52	75	135	98	M12x1.5 (4)	90°
RE 240	T-TR	A58x53 DIN 5482	60	60	—	95	165	145	12.5 (12)	30°
RE 310-510-610	N-P-T-TL	A58x53 DIN 5482	60	60	—	95	165	145	12.5 (12)	30°
RE 810	N-P-T	A70x64 DIN 5482	72	72	—	125	208	175	19(12)	30°
RE 1020-1520-2000	T-H	A80x74 DIN 5482	85	85	—	125	208	175	19(12)	30°
RE 2520-3000	H	A100x94 DIN 5482	105	105	—	170	254	212	21 (12)	30°
RE 3510-4800	H	N 120x3 DIN 5480	124	130	—	160	298	250	21 (12)	30°
RE 6000	H	N 120x3 DIN 5480	120	120	—	200	308	260	25 (12)	30°
RE 6000	H6	N 150x5 DIN 5480	151	151	—	240	385	320	32 (12)	30°
RE 8000	H	N 150x5 DIN 5480	151	151	—	240	385	320	32 (12)	30°
GB 12010-16000	H	N 170x5 DIN 5480	170	175	—	250	450	400	28 (18)	20°
GB 21000	H	N220x5 DIN 5480	220	230	—	315	500	450	32 (18)	20°

	VERSION	M	N	P	R	S	T	CODE
RE 110-210	N-P-T-TR	63	12	10	7.5	13.5	20.5	40000618
RE 240	T-TR	74	14	10	8	—	24	02571148
RE 310-510-610	N-P-T-TL	74	14	16	8	—	24	02571148
RE 810	N-P-T	90	21	14	10	—	29	40001838
RE 1020-1520-2000	T-H	90.5	21	14	9.5	—	30.5	40001848
RE 2520-3000	H	110	24	20	12	—	37	40001851
RE 3510-4800	H	150	30	20	28	—	29	02571068
RE 6000	H	125	31	19	11	—	30	02571054
RE 6000	H6	150	35	25	11	—	33	02571063
RE 8000	H	150	35	25	11	—	33	02571063
GB 12010-16000	H	163	42	48	14	—	42	02571048
GB 21000	H	205	47	70	16	—	51.5	02571049

On demand for different size

## BS

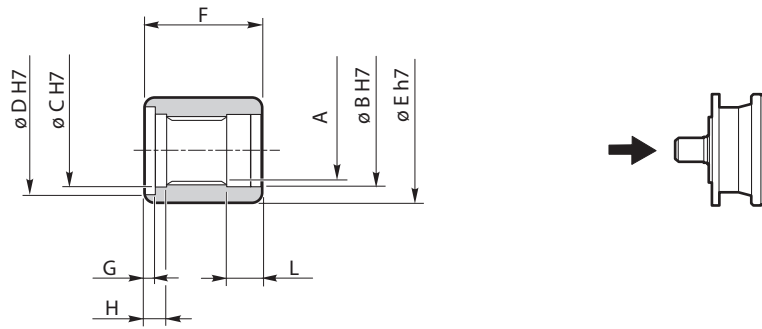

	VERSION	A	ø B	ø C	ø D	ø E	F	G	H	L	CODE
RE 110-210	N-P	A40x36 DIN 5482	42	42	—	60	55	—	7	20.5	40000608
RE 110-210	T-TR	A40x36 DIN 5482	42	42	51	60	67.5	5	12	20.5	40000617
RE 240	T-TR	A58x53 DIN 5482	60	60	72	94	85	16	23	25	40000642
RE 310-510-610	N-P-T-TL	A58x53 DIN 5482	60	60	72	94	85	16	23	25	40000642
RE 810	N-P-T	A70x64 DIN 5482	72	72	—	95	90	—	10	29	40001836
RE 1020-1520-2000	T-H	A80x74 DIN 5482	85	85	—	108	90.5	—	10.5	30.5	40001847
RE 2520-3000	H	A100x94 DIN 5482	105	105	—	136	110	—	12	33	40001850
RE 3510-4800	H	N120x3x9H DIN 5480	124	130	—	175	150	—	28	29	02631054
RE 6000	H	N120x3x9H DIN 5480	120	120	—	160	124.5	—	10.5	31	02631082
RE 6000	H6	N150x5x9H DIN 5480	151	151	—	220	150	—	11	33	02631092
RE 8000	H	N150x5x9H DIN 5480	151	151	—	220	150	—	11	33	02631092
GB 12010-16000	H	N170x5x9H DIN 5480	170	175	—	235	163	—	14	42	02631026
GB 21000	H	N220x5x9H DIN 5480	220	230	—	295	205	—	16	51.5	02631027

On demand for different size

## EP

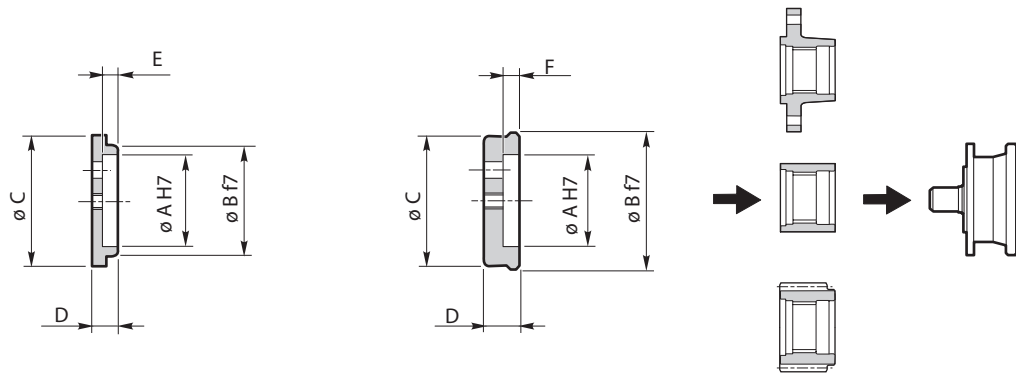

	VERSION	ø A	ø B	ø C	D	E	F	CODE
RE 110-210	N-P	35	42	50	9.5	4.5	—	40000609
RE 110-210	T-TR	35	52	50	14	—	6.8	40000614
RE 240	T-TR	50	60	70	13	5.5	—	40000613
RE 310-510	N-P	50	60	70	13	5.5	—	40000613
RE 310-510-610	T-TL	50	72	—	18	—	9	40000616
RE 810	N-P-T	62	72	80	18	9.25	—	40001832
RE 1020-1520-2000	T-H	70	85	98	19.5	8.5	—	40001840
RE 2520-3000	H	85	105	114	20	10	—	40001849
RE 3510-4800	H	90	130	—	26	—	14	02551072
RE 6000	H	100	120	135	21	9.5	—	02551060
RE 6000	H6	125	151	170	25	9	—	02551077
RE 8000	H	125	151	170	25	9	—	02551077
GB 12010-16000	H	150	175	198	31	13.5	—	02551044
GB 21000	H	200	230	260	43.5	19	—	02551046

On demand for different size

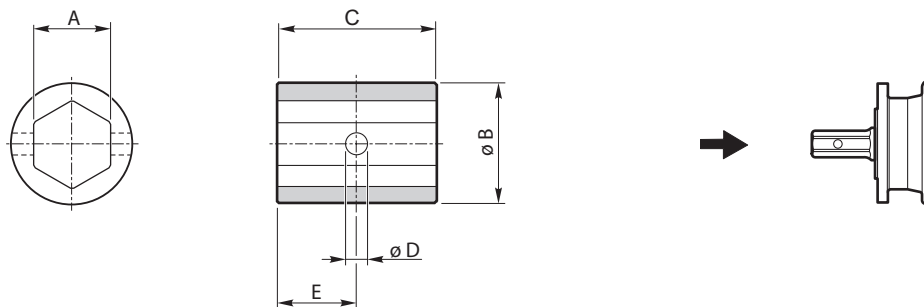
**ES**

	VERSION	A	øB	C	øD	E	CODE
<b>RE 110-210</b>	NE	50	80	108	18	54	40001831
<b>RE 240</b>	TE	50	80	108	18	54	40001831
<b>RE 310-510-610</b>	NE	50	80	108	18	54	40001831
<b>RE 310-510-610</b>	TE-TLE	70	100	115	—	—	40001813
<b>RE 810</b>	TE	70	100	115	—	—	40001813
<b>RE 1020-1520-2000</b>	TE	70	100	115	—	—	40001813

On demand for different size

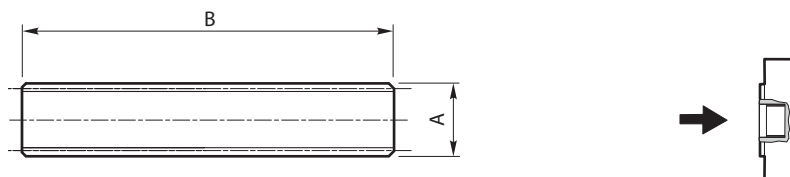
**BF**

	VERSION	A	B	CODE	Tmax [Nm]
<b>RE 110-210</b>	FS	B40x36 DIN 5482	250	40100901	2240
<b>RE 240</b>	FS	B45x41 DIN 5482	250	02631093	3255
<b>RE 310-510-610</b>	FS - NF	A58x53 DIN 5482	250	40100904	7055
<b>RE 810</b>	FS - NF	A70x64 DIN 548	250	40001855	12600
<b>RE 1020-1520-2000</b>	FS	A80x74 DIN 5482	250	40001856	19250
<b>RE 2520-3000</b>	FS	A100x94 DIN 5482	250	02631012	39450
<b>RE 3510-4800</b>	FS	W120x3x8f DIN 5480	250	02631086	97500
<b>RE 6000-8000</b>	FS	W140x5x8f DIN 5480	250	02631134	146000

On demand for different size

## VE

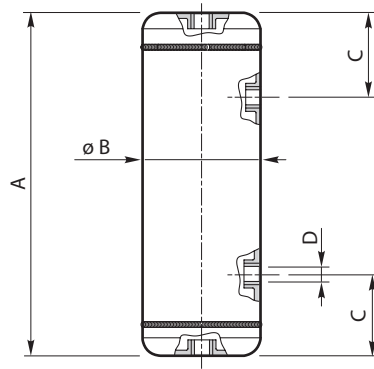

A	ø B	C	D	Capacity [Liters]	CODE
230	80	55	1/4" GAS (4)	1.0	40000712
330	130	85	1/4" GAS (4)	3.8	40000711
330	160	85	1/4" GAS (4)	5.5	40000710
510	150	85	1/4" GAS (4)	7.7	40000704
690	150	85	1/4" GAS (4)	10.7	40000706

On demand for different size

## GA

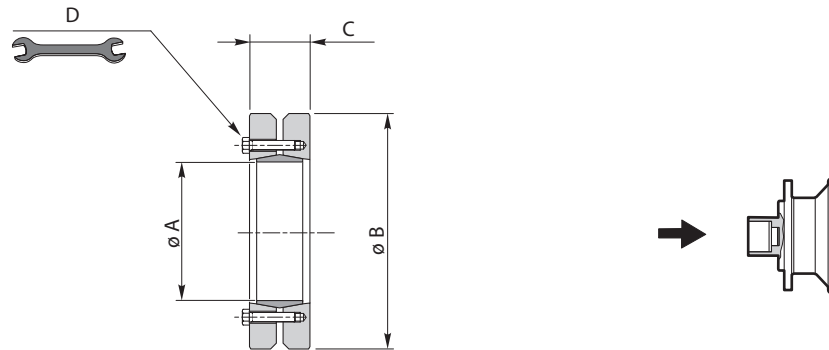

	VERSION	ø A	ø B	C	D	[Nm]	T max [Nm]
RE 110-210	NQ	62	110	29	M6-10.9 (10)	12	3000
RE 240-310-510-610	NQ-TQ	100	170	43	M8-10.9 (12)	30	9300
RE 810	TQ	125	215	53	M10-10.9 (12)	59	15800
RE 1020-1520-2000	HQ-TQ	165	290	68	M16-10.9 (8)	250	43600
RE 2520-3000	HQ	175	300	88	M16-10.9 (10)	250	59400
RE 3510-4800	HQ	185	330	85	M16-10.9 (10)	250	73100
RE 4800	HQ1	200	350	85	M16-10.9 (12)	250	94800
RE 6000-8000	HQ	195	350	112	M16-10.9 (15)	250	123000
RE 6000-8000	HQ1	240	405	108	M20-10.9 (12)	490	168000
GB 12010-16000	HQ	240	405	144	M20-10.9 (15)	490	236000
GB 12010-16000	HQ1	260	430	160	M20-10.9 (18)	490	325000
GB 21000-26000	HQ	280	460	172	M20-10.9 (20)	490	407000
GB 31000-40000	HQ	360	590	204	M24-10.9 (20)	840	753000
GB 45000	HQ	380	645	164	M24-10.9 (20)	840	739000
GB 53000-61000	HQ	390	660	212	M24-10.9 (24)	840	986000
GB 85000	HQ	460	770	252	M27-10.9 (28)	1250	1870000

On demand for different size

**BR**

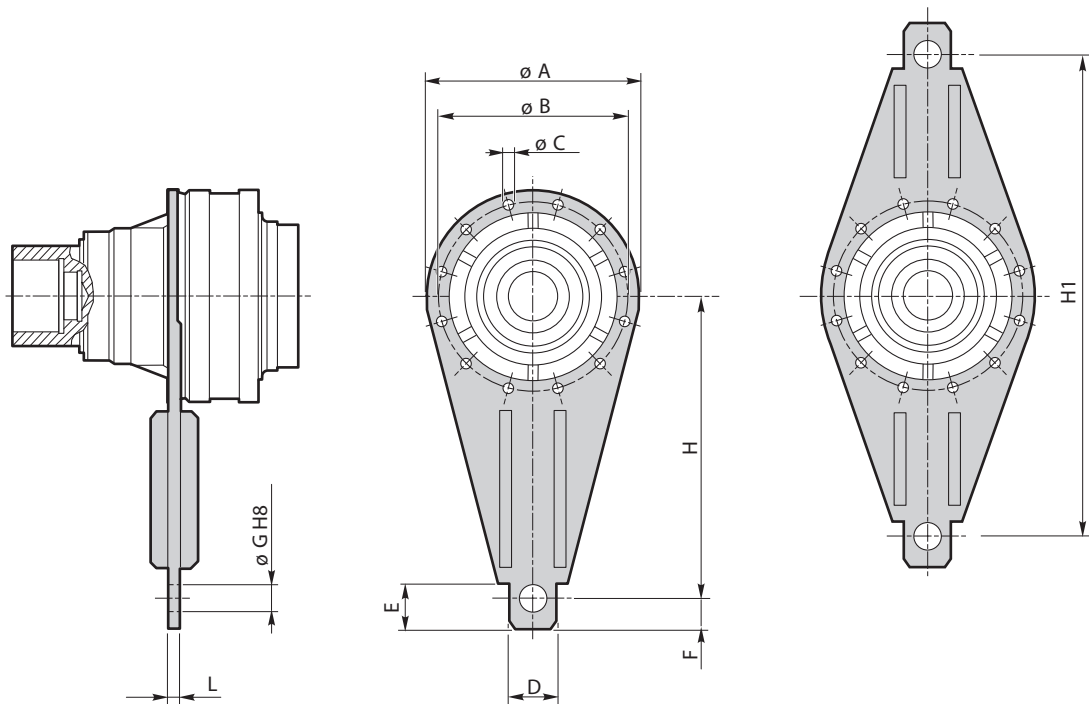

	VERSION	Ø A	Ø B	Ø C	D	E	F	Ø G	H	H1	L
RE 110-210	N	185	165	11 (8)	60	50	35	25	300	450	15
RE 110-210	T-TR	219	194	11 (10)	70	50	35	35	300	450	15
RE 240	TR	219	194	11 (10)	70	50	35	35	300	450	15
RE 240	T	219	195	13 (10)	60	50	35	30	350	500	15
RE 310-510-610	N-NU*	222	195	13 (10)	70	60	40	35	350	500	15
RE 810	T	280	250	15(12)	75	65	45	40	400	600	16
RE 1020	T	325	295	17 (10)	80	75	50	45	500	800	17
RE 1520-2000	T	325	295	17 (10)	80	75	50	45	500	800	17
RE 1520-2000	H	350	314	17(16)	80	75	50	45	500	800	17
RE 2520-3000	H	409	370	17(21)	95	125	60	50	700	1000	18
RE 3510-4800	H	452	424	17 (24)	100	130	65	50	800	1100	20
RE 6000-8000	H	490	445	19 (36)	110	140	70	55	900	1200	20
GB 12010-16000	H	610	560	25 (36)	120	120	80	60	1100	1400	22
GB 21000-26000	H	710	660	28 (36)	130	145	90	65	1300	1600	35
GB 31000	H	870	810	32 (36)	140	160	100	70	1500	2000	40
GB 40000-45000	H	870	810	32 (36)	140	160	100	70	1500	2000	40
GB 53000-61000-85000	H	1090	1020	39 (36)	160	170	110	75	1500	2000	80
GB 110000-130000	H	1540	1450	44 (40)	200	180	120	100	1800	2500	50

\* NU Torque arm code 02531016  
On demand for different size

P

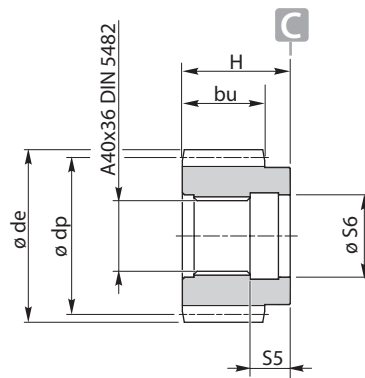

RE 110  
RE 210

M	z	x	$\varnothing de$	$\varnothing dp$	bu	H	S5	$\varnothing S6$	Code
4	20	0	88	80	42	55	20.5	$\varnothing 42 H7$	40100882
4	24	0	104	96	45	57	20.5	$\varnothing 42 H7$	40100889
4.5	14	0.5	76.5	63	55	55	20.5	$\varnothing 42 H7$	40100835
4.5	16	0	81	72	70	80	20.5	$\varnothing 42 H7$	40100802
4.5	16	0	81	72	45	55	20.5	$\varnothing 42 H7$	40100926
4.5	16	0	81	72	45	75	20.5	$\varnothing 42 H7$	40100943
5	14	0	80	70	60	60	20.5	$\varnothing 42 H7$	40100810
5	14	0	80	70	70	80	20.5	$\varnothing 42 H7$	40100812
5	14	0.5	85	70	65	65	20.5	$\varnothing 42 H7$	40100811
5	14	0.5	85	70	60	90	20.5	$\varnothing 42 H7$	40100885
5	14	0.5	85	70	55	78	20.5	$\varnothing 42 H7$	40100888
5	14	0.5	84.5	70	47	55	20.5	$\varnothing 42 H7$	02571014
5	16	0	90	80	70	80	20.5	$\varnothing 42 H7$	40100813
5	17	0	95	85	70	80	20.5	$\varnothing 42 H7$	40100815
5	18	0	100	90	70	80	20.5	$\varnothing 42 H7$	40100814
5	20	0	109.5	100	45	74	20.5	$\varnothing 42 H7$	40100918
5	22	0	120	110	50	76	20.5	$\varnothing 42 H7$	40100934
6	12	0.5	89	72	70	80	20.5	$\varnothing 42 H7$	40100825
6	13	0	90	78	60	85	20.5	$\varnothing 42 H7$	40100914
6	13	0	90	78	50	80	20.5	$\varnothing 42 H7$	40100915
6	13	0.5	95	78	61	97	20.5	$\varnothing 42 H7$	40100823
6	14	0	96	84	50	60	20.5	$\varnothing 42 H7$	40100824
6	14	0	96	84	70	80	20.5	$\varnothing 42 H7$	40100826
6	14	0	96	84	70	100	20.5	$\varnothing 42 H7$	40100827
6	15	0	102	90	60	82.5	20.5	$\varnothing 42 H7$	40100935
6	15	0.5	108	90	40	73	20.5	$\varnothing 42 H7$	40100819
6	17	0	114	102	80	110	20.5	$\varnothing 42 H7$	40100913
6	18	0	120	108	70	80	20.5	$\varnothing 42 H7$	40100830
6	20	0	132	120	60	85	20.5	$\varnothing 42 H7$	40100894
8	12	0.5	118	96	60	65	20.5	$\varnothing 42 H7$	40100841
8	14	0.5	136	112	80	110	20.5	$\varnothing 42 H7$	40100912
8	15	0	136	120	70	80	20.5	$\varnothing 42 H7$	40100846

On demand for different size

**P**

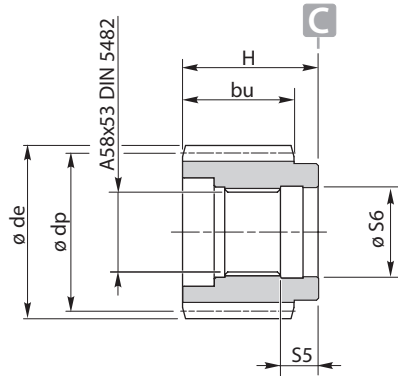

RE 240 / RE 310 / RE 510 / RE 610

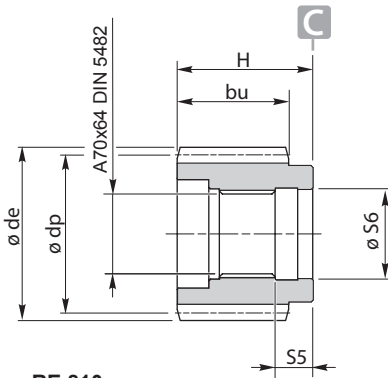

RE 810

	M	z	x	ø de	ø dp	bu	H	S5	ø S6	Code
<b>RE 240</b>	5	21	0	115	105	60	76	25	ø 60 H7	40100883
	5	22	0	120	110	50	76	25	ø 60 H7	02571051
	6	14	0.5	101.5	90	65	78	25	ø 60 H7	40100923
	6	16	0	108	96	70	80	25	ø 60 H7	40100867
	6	18	0	120	108	70	80	25	ø 60 H7	40100831
	6	20	0	132	120	75	80	25	ø 60 H7	40100873
	6	24	0	156	144	68	77.5	25	ø 60 H7	40100808
	7	14	0	112	98	78.5	78.5	25	ø 60 H7	40100874
	8	12	0.5	120	96	80	100	25	ø 60 H7	40100818
	8	13	0	120	104	68	78	25	ø 60 H7	02571111
	8	14	0	128	112	65	68	25	ø 60 H7	40100844
	8	14	0	128	112	75	85	25	ø 60 H7	40100845
	8	15	0	136	120	75	85	25	ø 60 H7	40100848
	8	16	0	144	128	75	85	25	ø 60 H7	40100849
	8	16	0.5	152	128	75	85	25	ø 60 H7	40100893
	8	17	0	149	136	78	110	25	ø 60 H7	40100937
	8	18	0	160	144	76	78	25	ø 60 H7	40100850
	8	18	0	160	144	96	98	25	ø 60 H7	40100898
	8	19	0	174	152	85	102	25	ø 60 H7	02571055
	<b>RE 310</b>	10	11	0.5	136	110	80	96.5	25	ø 60 H7
10		11	0.5	136	110	100	120.5	25	ø 60 H7	40100938
10		12	0.5	149	120	80	96.5	25	ø 60 H7	40100820
10		12	0.35	143	120	80	100	25	ø 60 H7	40100838
10		13	0	150	130	80	80	25	ø 60 H7	40100929
10		13	0	150	130	90	105	25	ø 60 H7	40100942
10		14	0	160	140	80	80	25	ø 60 H7	40100866
10		14	0	160	140	90	105	25	ø 60 H7	40100868
10		15	0	170	150	80	80	25	ø 60 H7	40100839
<b>RE 510</b>		10	11	0.5	136	110	80	96.5	25	ø 60 H7
	10	11	0.5	136	110	100	120.5	25	ø 60 H7	40100938
	10	12	0.5	149	120	80	96.5	25	ø 60 H7	40100820
	10	12	0.35	143	120	80	100	25	ø 60 H7	40100838
	10	13	0	150	130	80	80	25	ø 60 H7	40100929
	10	13	0	150	130	90	105	25	ø 60 H7	40100942
	10	14	0	160	140	80	80	25	ø 60 H7	40100866
	10	14	0	160	140	90	105	25	ø 60 H7	40100868
	10	15	0	170	150	80	80	25	ø 60 H7	40100839
	<b>RE 610</b>	10	11	0.5	136	110	80	96.5	25	ø 60 H7
10		11	0.5	136	110	100	120.5	25	ø 60 H7	40100938
10		12	0.5	149	120	80	96.5	25	ø 60 H7	40100820
10		12	0.35	143	120	80	100	25	ø 60 H7	40100838
10		13	0	150	130	80	80	25	ø 60 H7	40100929
10		13	0	150	130	90	105	25	ø 60 H7	40100942
10		14	0	160	140	80	80	25	ø 60 H7	40100866
10		14	0	160	140	90	105	25	ø 60 H7	40100868
10		15	0	170	150	80	80	25	ø 60 H7	40100839

	M	z	x	ø de	ø dp	bu	H	S5	ø S6	Code
<b>RE 810</b>	8	15	0.3	140.8	120	67	96	29	ø 72 H7	02571235
	8	17	0	152	136	80	99	29	ø 72 H7	02571121
	8	20	0	176	160	115	124	29	ø 72 H7	025710101
	8	23	0.5	208	184	86	131	29	ø 72 H7	40100853
	10	11	0.5	136	110	80	90	29	ø 72 H7	40100857
	10	12	0.5	150	120	90	90	29	ø 72 H7	02571110
	10	13	0.5	160	130	90	90	29	ø 72 H7	40100852
	10	13	0.5	160	130	99	99	29	ø 72 H7	02571000
	10	14	0	160	140	99	99	29	ø 72 H7	02571024
	10	14	0.5	170	140	67	96	29	ø 72 H7	02571236
	10	15	0	170	150	98	112	29	ø 72 H7	02571037
	10	15	0.5	180	150	98	112	29	ø 72 H7	02571183
	10	17	0.48	198	170	80	90	29	ø 72 H7	02571013
	12	11	0.5	167	132	90	120	29	ø 72 H7	40100821
	12	13	0.5	192	156	118	126	29	ø 72 H7	40100840
	12	13	0.3	187	156	75	90	29	ø 72 H7	02571019
	12	14	0.5	199	168	90	100	29	ø 72 H7	02571101
	14	12	0.3	205	168	80	110	29	ø 72 H7	02571102

On demand for different size

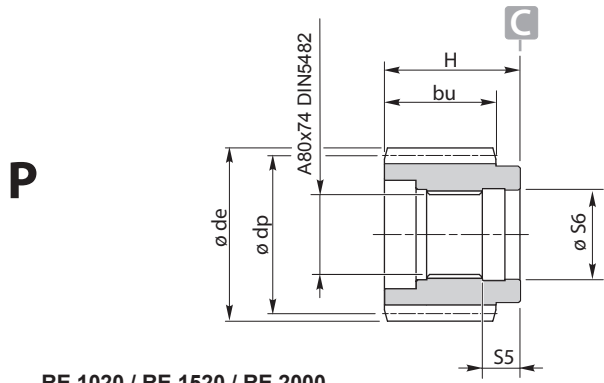

RE 1020 / RE 1520 / RE 2000

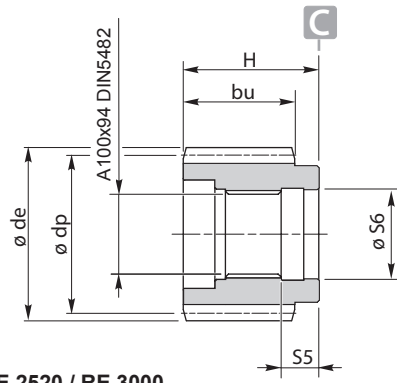

RE 2520 / RE 3000

	M	z	x	$\varnothing de$	$\varnothing dp$	bu	H	S5	$\varnothing S6$	Code
RE 1020 RE 1520 RE 2000	10	14	0.32	162.4	140	103	116	30.5	$\varnothing 85 H7$	02571001
	10	15	0	170	150	90	115	30.5	$\varnothing 85 H7$	40100940
	10	18	0	198	180	87	116	30.5	$\varnothing 85 H7$	40100822
	12	11	0.5	167	132	100	120	30.5	$\varnothing 85 H7$	02571136
	12	13	0.5	192	156	120	120	30.5	$\varnothing 85 H7$	02571173
	12	14	0.5	199	168	90.5	90.5	30.5	$\varnothing 85 H7$	40100856
	12	16	0	214	192	90	95	30.5	$\varnothing 85 H7$	40100850
	14	11	0.5	192.36	154	97	97	30.5	$\varnothing 85 H7$	025710113
	14	12	0.5	210	168	135	135	30.5	$\varnothing 85 H7$	02571182
	14	14	0.5	233.8	196	105	105	30.5	$\varnothing 85 H7$	02571103
	16	10	0.5	208	160	115	115	30.5	$\varnothing 85 H7$	025710126
	16	19	0	336	304	120	120	30.5	$\varnothing 85 H7$	02571006
	18	10	0.5	234	180	157	157	30.5	$\varnothing 85 H7$	02571152
	18	13	0.5	288	234	100	100	30.5	$\varnothing 85 H7$	02571208
20	14	0.5	340	280	125	140	30.5	$\varnothing 85 H7$	025710102	

	M	z	x	$\varnothing de$	$\varnothing dp$	bu	H	S5	$\varnothing S6$	Code
RE 2520 RE 3000	12	16	0.5	228.4	192	120	130	34	$\varnothing 105 H7$	02571044
	14	14	0	224	196	110	110	34	$\varnothing 105 H7$	02571030
	14	15	0.5	250.6	210	110	120	34	$\varnothing 105 H7$	02571221
	16	13	0.5	256	208	145	145	34	$\varnothing 105 H7$	02571201
	16	17	0.5	320	272	140	150	34	$\varnothing 105 H7$	02571159
	16	19	0.5	352	304	140	150	34	$\varnothing 105 H7$	02571167
	20	12	0.5	299	240	150	150	34	$\varnothing 105 H7$	02571176

On demand for different size

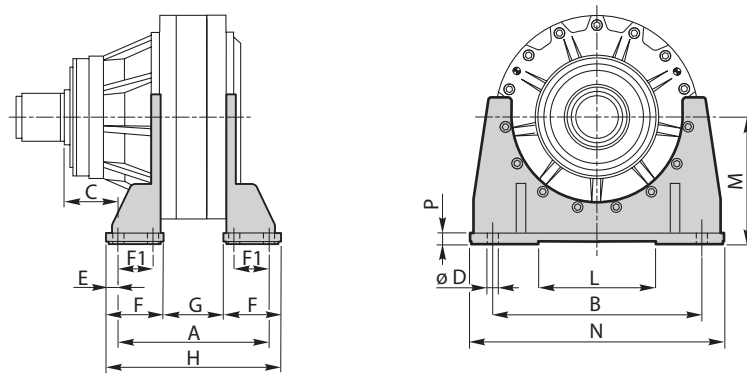

	A	B	C	øD	E	F	F1	G	H	L	M	N	P	Code
<b>RE 1520-2000</b>	310	356	80.5	25(8)	29.5	150.5	120.5	9	369	220	230	420	40	99448300
<b>RE 2520-3000</b>	334	457	78.5	33(8)	36	163.5	135	7	405	350	280	550	32.5	99448400

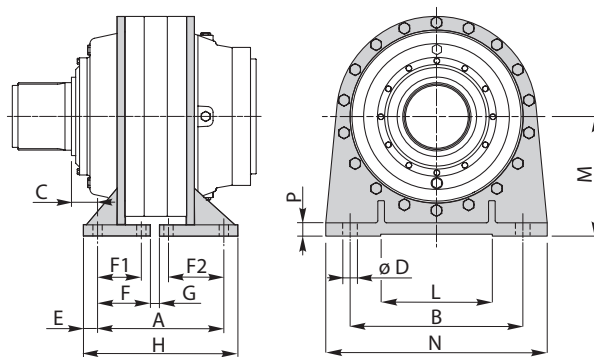

	A	B	C	øD	E	F	F1	F2	G	H	L	M	N	P	Code
<b>RE 3510-4800</b>	300	390	50	33(8)	35	116.5	92	154	5	370	235	270	500	29	99382000

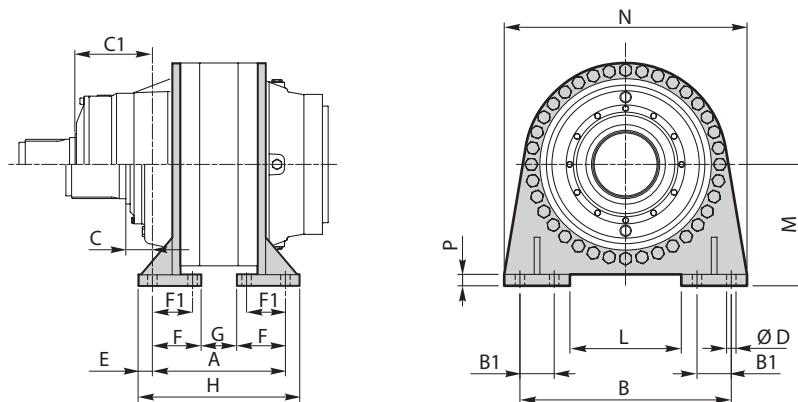

	A	B	B1	C	C1	øD	E	F	F1	G	H	L	M	N	P	Code
<b>RE 6000</b>	410	508	-	-	114.5	33(8)	43.5	194	160	22	497	340	315	610	35	99452100
<b>RE 6000 H6</b>	401.5	508		14.5	-	33(8)	43.5	194	160	13.5	488.5	340	315	610	35	99450600
<b>RE 8000</b>	404.5	508	--	14.5	-	33(8)	43.5	194	160	16.5	491.5	340	315	610	35	99450600
<b>GB 12010-16000</b>	416	630	100	52	-	32(12)	40	185	145	46	496	340	360	720	38	99335300
<b>GB 21000</b>	432	740	120	62	-	33(12)	50	150	170	37	532	390	425	850	42	99451200
<b>GB 26000</b>	452	740	120	62	-	33(12)	50	150	170	57	552	390	425	850	42	99451300
<b>GB 31000</b>	550	900	150	75	-	45(12)	75	262.5	214.5	25	700	480	530	1020	50	99352800
<b>GB 40000-45000</b>	590	900	150	75		45(12)	75	262.5	214.5	65	740	480	530	1020	50	99446400
<b>GB 53000-61000</b>	645	1100	200	81	—	52(8)	80	200	—	245	805	550	640	1250	60	99180000
<b>GB 85000</b>	693	1100	200	81	—	52(8)	80	200	—	293	853	550	640	1250	60	99180100
<b>GB110000-130000 150000</b>	865	1520	380	68	—	60(8)	72.5	245.5	—	354	1110	610	950	1750	80	—
<b>GB 205000-235000</b>	1090	1770	380	176	—	85(8)	99	326	—	438	1288	780	1050	2000	102	—

On demand for different size

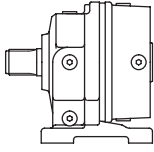
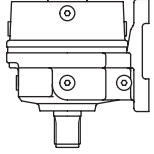
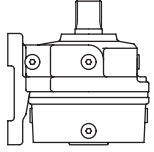
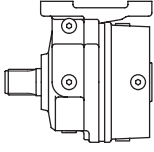
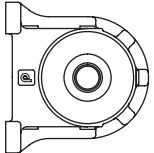
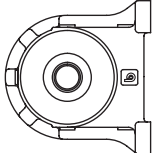
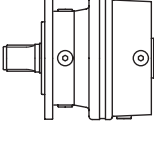
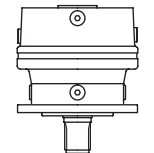
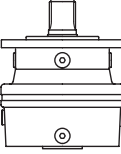
			
<b>B3</b>	<b>V5</b>	<b>V6</b>	<b>B8</b>
			
<b>B6</b>	<b>B7</b>	<b>B5</b>	<b>V1</b>
			
<b>V3</b>			

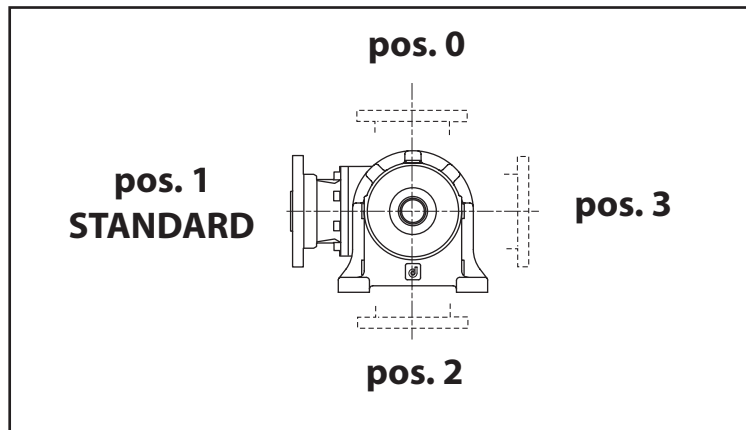

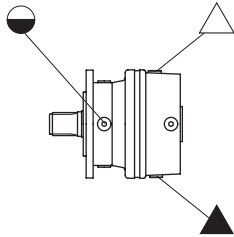
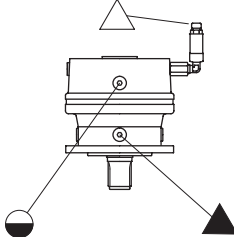
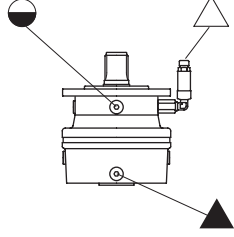
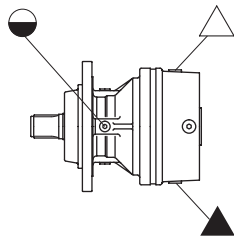
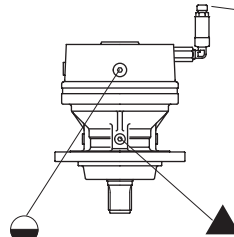
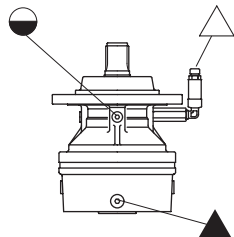
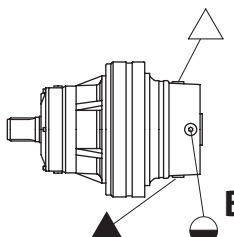
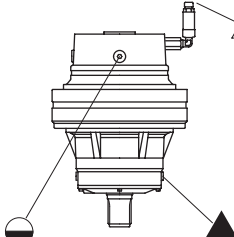
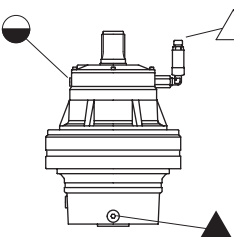
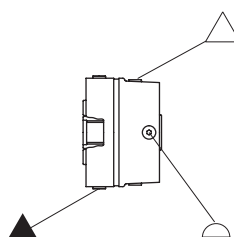
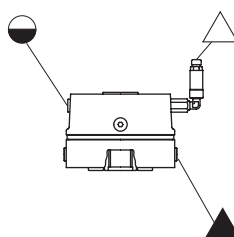
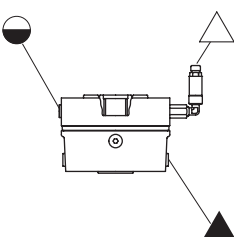
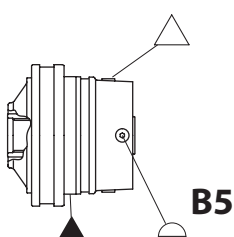
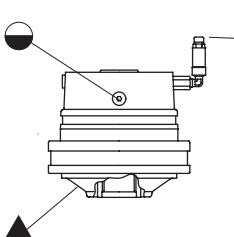
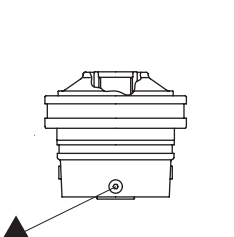
<b>N</b>	 <p><b>B5</b></p>	 <p><b>V1</b></p>	 <p><b>V3</b></p>
<b>110÷810</b>			
<b>T-TL-TR</b>	 <p><b>B5</b></p>	 <p><b>V1</b></p>	 <p><b>V3</b></p>
<b>110÷2000</b>			
<b>H</b>	 <p><b>B5</b></p>	 <p><b>V1</b></p>	 <p><b>V3</b></p>
<b>1520÷235000</b>			
<b>F</b>	 <p><b>B5</b></p>	 <p><b>V1</b></p>	 <p><b>V3</b></p>
<b>110÷240</b>			
<b>F</b>	 <p><b>B5</b></p>	 <p><b>V1</b></p>	 <p><b>V3</b></p>
<b>310÷2000</b>			

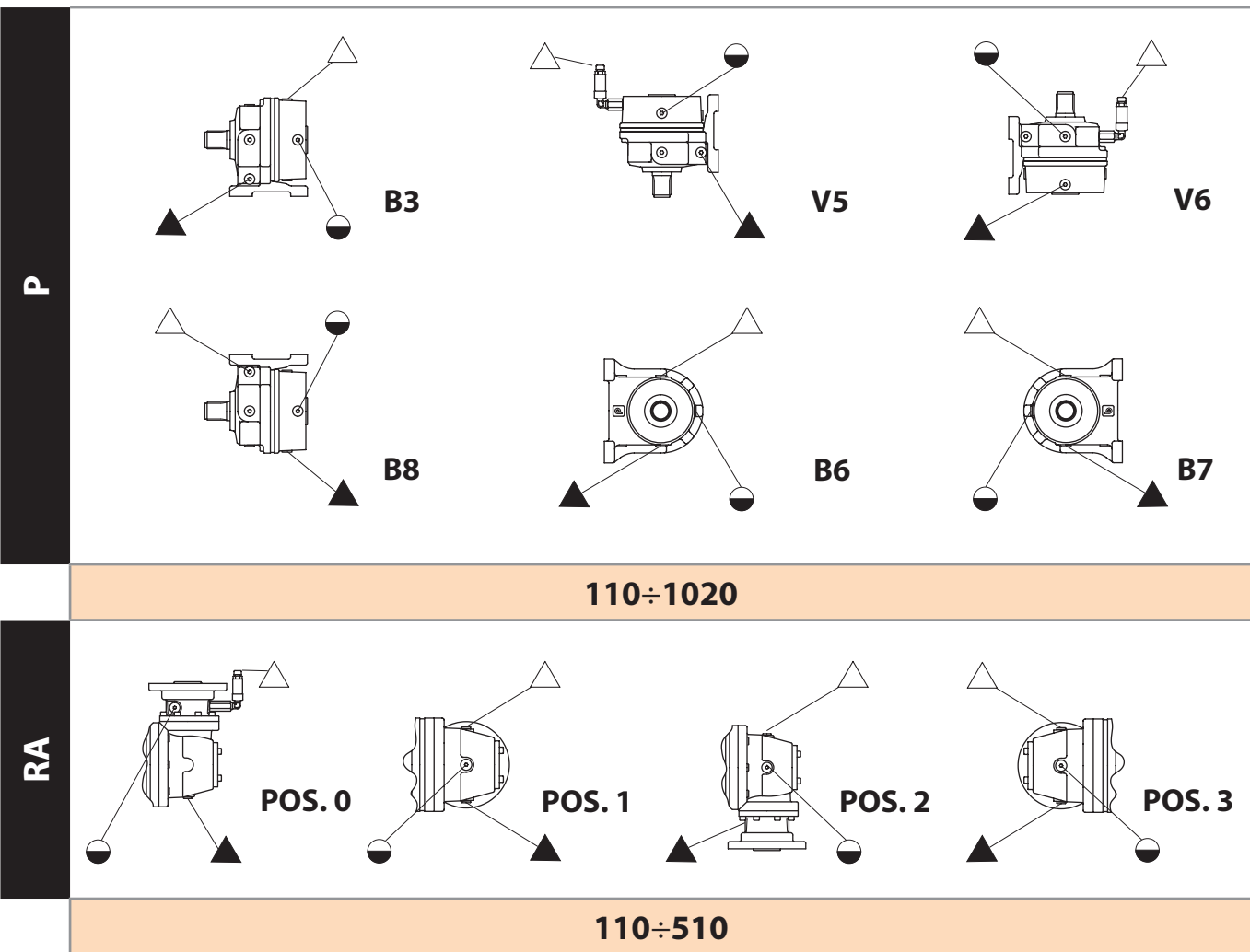

[Liters]

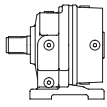
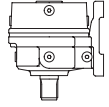
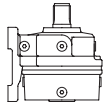
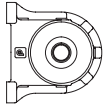
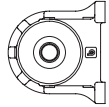
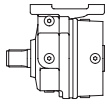
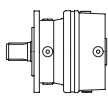
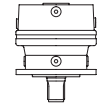
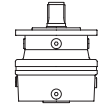

	B3	V5	V6	B6	B7	B8	B5	V1	V3
									
RE 111	0.7	1.4	1.4	0.7	0.7	0.7	0.4	0.8	0.8
RE 112	0.9	1.8	1.8	0.9	0.9	0.9	0.5	1	1
RE 113	1.1	2.2	2.2	1.1	1.1	1.1	0.7	1.4	1.4
RE 114	1.3	2.6	2.6	1.3	1.3	1.3	0.8	1.6	1.6
RE 211	0.8	1.6	1.6	0.8	0.8	0.8	0.5	1	1
RE 212	1	2	2	1	1	1	0.6	1.2	1.2
RE 213	1.2	2.4	2.4	1.2	1.2	1.2	0.7	1.4	1.4
RE 214	1.4	2.8	2.8	1.4	1.4	1.4	0.9	1.8	1.8
RE 241	0.8	1.6	1.6	0.8	0.8	0.8	0.5	1	1
RE 242	1	2	2	1	1	1	0.6	1.2	1.2
RE 243	1.2	2.4	2.4	1.2	1.2	1.2	0.7	1.4	1.4
RE 244	1.4	2.8	2.8	1.4	1.4	1.4	0.9	1.8	1.8
RE 311	1.4	2.8	2.8	1.4	1.4	1.4	1	2	2
RE 312	1.6	3.2	3.2	1.6	1.6	1.6	1.2	2.4	2.4
RE 313	1.7	3.4	3.4	1.7	1.7	1.7	1.3	2.6	2.6
RE 314	1.8	3.6	3.6	1.8	1.8	1.8	1.4	2.8	2.8
RE 511	1.5	3	3	1.5	1.5	1.5	1.1	2.2	2.2
RE 512	1.7	3.4	3.4	1.7	1.7	1.7	1.3	2.6	2.6
RE 513	1.8	3.6	3.6	1.8	1.8	1.8	1.5	3	3
RE 514	1.9	3.8	3.8	1.9	1.9	1.9	1.6	3.2	3.2
RE 611	1.6	3.2	3.2	1.6	1.6	1.6	1.2	2.4	2.4
RE 612	1.8	3.6	3.6	1.8	1.8	1.8	1.4	2.8	2.8
RE 613	1.9	3.8	3.8	1.9	1.9	1.9	1.6	3.2	3.2
RE 614	20	40	40	20	20	20	1.7	3.4	3.4
RE 811	1.8	3.6	3.6	1.8	1.8	1.8	1.5	3	3
RE 812	2	4	4	2	2	2	1.7	3.4	3.4
RE 813	2.2	4.4	4.4	2.2	2.2	2.2	1.9	3.8	3.8
RE 814	2.3	4.6	4.6	2.3	2.3	2.3	2	4	4
RE 1021	2.4	4.8	4.8	2.4	2.4	2.4	2.1	4.2	4.2
RE 1022	2.6	5.2	5.2	2.6	2.6	2.6	2.3	4.6	4.6
RE 1023	2.7	5.4	5.4	2.7	2.7	2.7	2.4	4.8	4.8
RE 1024	2.9	5.8	5.8	2.9	2.9	2.9	2.6	5.2	5.2

[Liters]	B5	V1	V3
RE 1521	2.7	5.4	5.4
RE 1522	3	6	6
RE 1523	3.2	6.4	6.4
RE 1524	3.4	6.8	6.8
RE 2001	2.7	5.4	5.4
RE 2002	3	6	6
RE 2003	3.3	6.6	6.6
RE 2004	3.4	6.8	6.8
RE 2002L	3	6	6
RE 2003L	3.1	6.2	6.2
RE 2004L	3.2	6.4	6.4
RE 2521	3.9	7.7	7.7
RE 2522	4.5	9	9
RE 2523	4.7	9.4	9.4
RE 2524	5	9.9	9.9
RE 3001	3.8	7.6	7.6
RE 3002	4.6	9.1	9.1
RE 3003	4.8	9.5	9.5
RE 3004	5	10	10
RE 3511	4.9	9.8	9.8
RE 3512	5.7	11.4	11.4
RE 3513	6	12	12
RE 3514	6.2	12.4	12.4
RE 4801	4.7	9.4	9.4
RE 4802	6.8	13.6	13.6
RE 4803	7.2	14.4	14.4
RE 4804	7.4	14.8	14.8
RE 6001	7.5	15	15
RE 6002	8.5	17	17
RE 6003	9	18	18
RE 6004	9.3	18.6	18.6
RE 6002L	8.5	17	17
RE 6003L	9	18	18

[Liters]	B5	V1	V3
RE 6004L	9.2	18.4	18.4
RE 8001	8.3	16.6	16.6
RE 8002	10.2	20.4	20.4
RE 8003	11	22	22
RE 8004	11.5	23	23
RE 8005	11.7	23.4	23.4
RE 8002L	10.2	20.4	20.4
RE 8003L	10.8	21.6	21.6
RE 8004L	11.4	22.8	22.8
RE 8005L	11.6	23.2	23.2
GB 12011	13.5	27	27
GB 12012	15.5	31	31
GB 12013	16.5	33	33
GB 12014	16.8	33.6	33.6
GB 12015	17	34	34
GB 12012L	15.5	31	31
GB 12013L	16.3	32.6	32.6
GB 12014L	16.7	33.4	33.4
GB 12015L	17	34	34
GB 16001	14.5	29	29
GB 16002	18	36	36
GB 16003	19.2	38.4	38.4
GB 16004	19.6	39.2	39.2
GB 16005	19.8	39.6	39.6
GB 16002L	17	34	34
GB 16003L	18	36	36
GB 16004L	18.5	37	37
GB 16005L	18.7	37.4	37.4
GB 21001	20	40	40
GB 21002	23.5	47	47
GB 21003	24.5	49	49
GB 21004	25	50	50
GB 21005	25.5	51	51

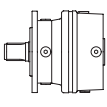
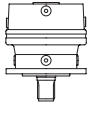
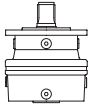
[Liters]	B5	V1	V3
			
<b>GB 26001</b>	20	40	40
<b>GB 26002</b>	25.5	51	51
<b>GB 26003</b>	27.5	55	55
<b>GB 26004</b>	28.5	57	57
<b>GB 26005</b>	29	58	58
<b>GB 31001</b>	38	76	76
<b>GB 31002</b>	46.5	93	93
<b>GB 31003</b>	48.5	97	97
<b>GB 31004</b>	49.5	99	99
<b>GB 31005</b>	50	100	100
<b>GB 40001</b>	41	82	82
<b>GB 40002</b>	49	98	98
<b>GB 40003</b>	51	102	102
<b>GB 40004</b>	52	104	104
<b>GB 40005</b>	52	104	104
<b>GB 45001</b>	41	82	82
<b>GB 45002</b>	50	100	100
<b>GB 45003</b>	53.5	107	107
<b>GB 45004</b>	55	110	110
<b>GB 45005</b>	55.5	111	111
<b>GB 53001</b>	70	140	140
<b>GB 53002</b>	80	160	160
<b>GB 53003</b>	85	170	170
<b>GB 53004</b>	86.5	173	173
<b>GB 53005</b>	87	174	174
<b>GB 61001</b>	70	140	140
<b>GB 61002</b>	80	160	160
<b>GB 61003</b>	85	170	170
<b>GB 61004</b>	86.5	173	173
<b>GB 61005</b>	87	174	174
<b>GB 85001</b>	75	150	150
<b>GB 85002</b>	87.5	175	175
<b>GB 85003</b>	93	186	186

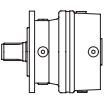
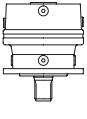
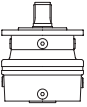
[Liters]	B5	V1	V3
			
<b>GB 85004</b>	95	190	190
<b>GB 85005</b>	95.5	191	191
<b>GB 110001</b>	145	290	290
<b>GB 110002</b>	170	340	340
<b>GB 110003</b>	180	360	360
<b>GB 110004</b>	183	366	366
<b>GB 110005</b>	185	370	370
<b>GB 130001</b>	144	288	288
<b>GB 130002</b>	172	344	344
<b>GB 130003</b>	181	362	362
<b>GB 130004</b>	185	370	370
<b>GB 130005</b>	186	372	372
<b>GB 150001</b>	143	286	286
<b>GB 150002</b>	172	344	344
<b>GB 150003</b>	185	370	370
<b>GB 150004</b>	187	374	374
<b>GB 150005</b>	188	376	376
<b>GB 205001</b>	255	510	510
<b>GB 205002</b>	300	600	600
<b>GB 205003</b>	318	636	636
<b>GB 205004</b>	326	652	652
<b>GB 205005</b>	329	658	658
<b>GB 235001</b>	255	510	510
<b>GB 235002</b>	300	600	600
<b>GB 235003</b>	335	670	670
<b>GB 235004</b>	345	690	690
<b>GB 235005</b>	247	494	494

[Liters]	B3-1	V5	V6	B6-1	B7	B8	B5-1	V1	V3
RA 112	1.5	3	3	1.5	3	3	1.2	2.4	2.4
RA 113	1.7	3.4	3.4	1.7	3.4	3.4	1.3	2.6	2.6
RA 114	1.9	3.8	3.8	1.9	3.8	3.8	1.5	3	3
RA 212	1.6	3.2	3.2	1.6	3.2	3.2	1.3	2.6	2.6
RA 213	1.8	3.6	3.6	1.8	3.6	3.6	1.4	2.8	2.8
RA 214	2	4	4	2	4	4	1.5	3	3
RA 242	1.6	3.2	3.2	1.6	3.2	3.2	1.3	2.6	2.6
RA 243	1.8	3.6	3.6	1.8	3.6	3.6	1.4	2.8	2.8
RA 244	2	4	4	2	4	4	1.5	3	3
RA 312	2.5	5	5	2.5	5	5	2.1	4.2	4.2
RA 313	2.4	4.8	4.8	2.4	4.8	4.8	2	4	4
RA 314	2.5	5	5	2.5	5	5	2.1	4.2	4.2
RA 512	2.6	5.2	5.2	2.6	5.2	5.2	2.2	4.4	4.4
RA 513	2.5	5	5	2.5	5	5	2.1	4.2	4.2
RA 514	2.6	5.2	5.2	2.6	5.2	5.2	2.3	4.6	4.6
RA 612	2.7	5.4	5.4	2.7	5.4	5.4	2.3	4.6	4.6
RA 613	2.9	5.8	5.8	2.9	5.8	5.8	2.5	5	5
RA 614	2.7	5.4	5.4	2.7	5.4	5.4	2.4	4.8	4.8
RA 812	3.8	7.6	7.6	3.8	7.6	7.6	3.5	7	7
RA 813	3.1	6.2	6.2	3.1	6.2	6.2	2.8	5.6	5.6
RA 814	3	6	6	3	6	6	2.7	5.4	5.4
RA 1022	4.4	8.8	8.8	4.4	8.8	8.8	4.1	8.2	8.2
RA 1023	3.7	7.4	7.4	3.7	7.4	7.4	3.4	6.8	6.8
RA 1024	3.5	7	7	3.5	7	7	3.2	6.4	6.4

[Liters]	B5-1	V1	V3
RA 1522	5.7	11.4	11.4
RA 1523	4.1	8.2	8.2
RA 1524	4	8	8
RA 2002	5.7	11.4	11.4
RA 2003	4.1	8.2	8.2
RA 2004	4.1	8.2	8.2
RA 2003L	4.1	8.2	8.2
RA 2004L	3.9	7.8	7.8
RA 2522	10.7	21.4	21.4
RA 2523	11	22	22
RA 2524	10.5	21	21
RA 3002	10.6	21.2	21.2
RA 3003	11.1	22.2	22.2
RA 3004	10.6	21.2	21.2
RA 3512	14.9	29.8	29.8
RA 3513	7.7	15.4	15.4
RA 3514	7.1	14.2	14.2
RA 4802	14.7	29.4	29.4
RA 4803	9.8	19.6	19.6
RA 4804	8.3	16.6	16.6
RA 6002	17.5	35	35
RA 6003	11.5	23	23
RA 6004	10.1	20.2	20.2
RA 6003L	11.5	23	23
RA 6004L	10.1	20.2	20.2
RA 8002	18.3	36.6	36.6
RA 8003	13.2	26.4	26.4
RA 8004	13	26	26
RA 8003L	13.2	26.4	26.4
RA 8004L	12.8	25.6	25.6
GBA 12013	18.5	37	37
GBA 12014	18.5	37	37
GBA 12015	17.9	35.8	35.8
GBA 12013L	18.5	37	37
GBA 12014L	18.3	36.6	36.6
GBA 12015L	18	36	36
GBA 16003	28	56	56
GBA 16004	22.2	44.4	44.4
GBA 16005	20.7	41.4	41.4

[Liters]	B5-1	V1	V3
GBA 16003L	27	54	54
GBA 16004L	21	42	42
GBA 16005L	19.6	39.2	39.2
GBA 21003	33.5	67	67
GBA 21004	27.5	55	55
GBA 21005	26.1	52.2	52.2
GBA 26003	35.5	71	71
GBA 26004	30.5	61	61
GBA 26005	30.5	61	61
GBA 31004	51.5	103	103
GBA 31005	51.5	103	103
GBA 40004	54	108	108
GBA 40005	54	108	108
GBA 45004	63.5	127	127
GBA 45005	58.5	117	117
GBA 53004	96.5	193	193
GBA 53005	90	180	180
GBA 61004	95	190	190
GBA 61005	89.5	179	179
GBA 61006	88	176	176
GBA 85004	103	206	206
GBA 85005	98	196	196
GBA 85006	97	194	194
GBA 110005	186	372	372
GBA 110006	187	374	374
GBA 130005	380	760	388
GBA 130006	189	378	378

CC		
[Liters]		
CC30	1.6	Complete filling
CC120	2.2	
CC350	4	
CC600	6	
CC1000	16	

	P	T	TL	TR	F	N	H
RE 111	23	20	—	20	14	17	—
RE 112	29.5	26.5	—	26.5	21	24	—
RE 113	36.5	33.5	—	33.5	27.5	30.5	—
RE 114	43	40	—	40	34	37	—
RE 211	25	22	—	22	16	19	—
RE 212	32	29	—	29	23	26	—
RE 213	38	35	—	35	30	32	—
RE 214	45	42	—	42	37	39	—
RE 241	25	22	—	22	16	—	—
RE 242	32	29	—	29	23	—	—
RE 243	38	35	—	35	30	—	—
RE 244	45	42	—	42	37	—	—
RE 311	52	47	47	—	24	35	—
RE 312	59	54	54	—	31	42	—
RE 313	66	61	61	—	38	49	—
RE 314	72	67	66	—	45	56	—
RE 511	57	52	52	—	29	40	—
RE 512	66	61	61	—	38	49	—
RE 513	73	68	68	—	45	56	—
RE 514	80	75	75	—	52	63	—
RE 611	58	53	53	—	30	41	—
RE 612	72	67	67	—	44	55	—
RE 613	79	74	74	—	51	62	—
RE 614	86	81	81	—	58	69	—
RE 811	80	70	—	—	—	67	—
RE 812	94	84	—	—	—	80	—
RE 813	100	90	—	—	—	87	—
RE 814	107	97	—	—	—	94	—
RE 1021	100	90	—	—	60	—	—
RE 1022	117	107	—	—	77	—	—

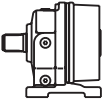
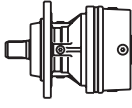
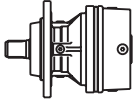
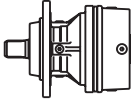
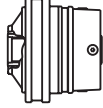
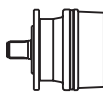
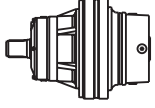
	P	T	TL	TR	F	N	H
							
RE 1023	126	116	—	—	86	—	—
RE 1024	133	123	—	—	93	—	—
RE 1521	—	123	—	—	84	—	130
RE 1522	—	141	—	—	102	—	148
RE 1523	—	149	—	—	110	—	156
RE 1524	—	156	—	—	117	—	163
RE 2001	—	124	—	—	85	—	131
RE 2002	—	142	—	—	104	—	150
RE 2003	—	156	—	—	118	—	163
RE 2004	—	163	—	—	125	—	170
RE 2002L	—	137	—	—	99	—	145
RE 2003L	—	149	—	—	111	—	156
RE 2004L	—	153	—	—	115	—	160
RE 2521	—	—	—	—	151	—	185
RE 2522	—	—	—	—	180	—	214
RE 2523	—	—	—	—	194	—	228
RE 2524	—	—	—	—	201	—	235
RE 3001	—	—	—	—	152	—	186
RE 3002	—	—	—	—	199	—	233
RE 3003	—	—	—	—	207	—	241
RE 3004	—	—	—	—	216	—	250
RE 3511	—	—	—	—	225	—	239
RE 3512	—	—	—	—	260	—	274
RE 3513	—	—	—	—	278	—	292
RE 3514	—	—	—	—	287	—	301
RE 4801	—	—	—	—	226	—	240
RE 4802	—	—	—	—	311	—	325
RE 4803	—	—	—	—	330	—	344
RE 4804	—	—	—	—	339	—	353

	H	F
RE 6002L	365	340
RE 6003L	375	350
RE 6004L	382	357
RE 6001	315	290
RE 6002	370	345
RE 6003	390	365
RE 6004	395	370
RE 8001	410	380
RE 8002	500	470
RE 8003	540	510
RE 8004	555	525
RE 8005	560	530
RE 8002L	485	455
RE 8003L	520	490
RE 8004L	530	500
RE 8005L	535	505
GB 12011	650	615
GB 12012	750	715
GB 12013	785	750
GB 12014	800	765
GB 12015	810	775
GB 12012L	700	665
GB 12013L	745	710
GB 12014L	750	715
GB 12015L	757	722
GB 16001	690	655
GB 16002	860	825
GB 16003	915	880
GB 16004	935	900
GB 16005	940	905
GB 16002L	860	825
GB 16003L	865	830
GB 16004L	885	850
GB 16005L	890	855
GB 21001	930	880
GB 21002	1115	1065
GB 21003	1165	1115
GB 21004	1190	1140
GB 21005	1205	1155
GB 26001	980	920
GB 26002	1230	1170
GB 26003	1330	1270
GB 26004	1360	1300
GB 26005	1380	1320
GB 31001	1900	1750
GB 31002	2280	2130
GB 31003	2375	2225
GB 31004	2410	2260
GB 31005	2425	2275
GB 40001	2030	1880

	H	F
GB 40002	2400	2250
GB 40003	2500	2350
GB 40004	2530	2380
GB 40005	2540	2390
GB 45001	2030	1880
GB 45002	2435	2285
GB 45003	2610	2460
GB 45004	2665	2515
GB 45005	2682	2532
GB 53001	3550	3200
GB 53002	4060	3710
GB 53003	4250	3900
GB 53004	4350	4000
GB 53005	4370	4020
GB 61001	3550	3200
GB 61002	4060	3710
GB 61003	4250	3900
GB 61004	4350	4000
GB 61005	4370	4020
GB 85001	3850	3450
GB 85002	4410	4010
GB 85003	4650	4250
GB 85004	4750	4350
GB 85005	4785	4385
GB 110001	7520	6620
GB 110002	8780	7880
GB 110003	9155	8255
GB 110004	9250	8350
GB 110005	9285	8385
GB 130001	7535	6635
GB 130002	8800	7900
GB 130003	9210	8310
GB 130004	9380	8480
GB 130005	9430	8530
GB 150001	7550	6650
GB 150002	8795	7895
GB 150003	9280	8380
GB 150004	9460	8560
GB 150005	9500	8600
GB 205001	12240	11790
GB 205002	14330	13880
GB 205003	15040	14590
GB 205004	15410	14960
GB 205005	15500	15050
GB 235001	12250	11800
GB 235002	14580	14130
GB 235003	15830	15380
GB 235004	16200	15750
GB 235005	16300	15850

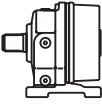
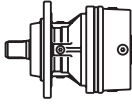
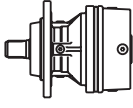
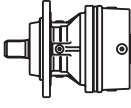
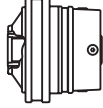
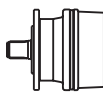
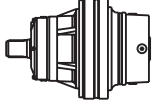
	P	T	TL	TR	F	N	H
							
RA 112	43	40	—	40	34	37	—
RA 113	49.5	46.5	—	46.5	41	44	—
RA 114	56.5	53.5	—	53.5	47.5	50.5	—
RA 212	45	42	—	42	36	39	—
RA 213	52	49	—	49	43	46	—
RA 214	58	55	—	55	50	52	—
RA 242	45	—	—	42	—	—	—
RA 243	52	—	—	49	—	—	—
RA 244	58	—	—	55	—	—	—
RA 312	102	97	97	—	74	85	—
RA 313		74	74	—	51	62	—
RA 314	86	81	81	—	58	69	—
RA 512	107	102	102	—	79	90	—
RA 513	86	81	81	—	58	69	—
RA 514	93	88	88	—	65	76	—
RA 612	108	103	103	—	80	91	—
RA 613	122	117	117	—	94	105	—
RA 614	99	94	94	—	71	82	—
RA 812	170	160	—	—	—	157	—
RA 813	144	134	—	—	—	130	—
RA 814	120	110	—	—	—	107	—
RA 1022	190	180	—	—	150	—	—
RA 1023	167	157	—	—	127	—	—
RA 1024	146	136	—	—	106	—	—
RA 1522	—	258	—	—	219	—	265
RA 1523	—	191	—	—	152	—	198
RA 1524	—	169	—	—	130	—	176
RA 2002	—	259	—	—	220	—	266
RA 2003	—	192	—	—	154	—	200
RA 2004	—	176	—	—	138	—	183
RA 2003L	—	187	—	—	149	—	195
RA 2004L	—	169	—	—	131	—	176
RA 2522	—	—	—	—	286	—	320
RA 2523	—	—	—	—	270	—	304
RA 2524	—	—	—	—	214	—	248
RA 3002	—	—	—	—	287	—	321
RA 3003	—	—	—	—	289	—	323
RA 3004	—	—	—	—	257	—	291
RA 3512	—	—	—	—	575	—	589
RA 3513	—	—	—	—	350	—	364
RA 3514	—	—	—	—	398	—	412
RA 4802	—	—	—	—	576	—	590
RA 4803	—	—	—	—	446	—	460
RA 4804	—	—	—	—	380	—	394

	H	F
<b>RA 6002</b>	665	640
<b>RA 6003</b>	505	480
<b>RA 6004</b>	440	415
<b>RA 6003L</b>	500	475
<b>RA 6004L</b>	425	400
<b>RA 8002</b>	760	730
<b>RA 8003</b>	635	605
<b>RA 8004</b>	630	600
<b>RA 8003L</b>	620	590
<b>RA 8004L</b>	610	580
<b>GBA 12013</b>	885	850
<b>GBA 12014</b>	875	840
<b>GBA 12015</b>	850	815
<b>GBA 12013L</b>	835	800
<b>GBA 12014L</b>	835	800
<b>GBA 12015L</b>	800	765
<b>GBA 16003</b>	1210	1175
<b>GBA 16004</b>	1050	1015
<b>GBA 16005</b>	985	950
<b>GBA 16003L</b>	1210	1175
<b>GBA 16004L</b>	1000	965
<b>GBA 16005L</b>	935	900
<b>GBA 21003</b>	1465	1415
<b>GBA 21004</b>	1300	1250
<b>GBA 21005</b>	1240	1190
<b>GBA 26003</b>	1580	1520
<b>GBA 26004</b>	1465	1405
<b>GBA 26005</b>	1450	1390
<b>GBA 31004</b>	2510	2360
<b>GBA 31005</b>	2500	2350
<b>GBA 40004</b>	2635	2485
<b>GBA 40005</b>	2620	2470
<b>GBA 45004</b>	2960	2810
<b>GBA 45005</b>	2800	2650
<b>GBA 53004</b>	4600	4250
<b>GBA 53005</b>	4485	4135
<b>GBA 61004</b>	4600	4250
<b>GBA 61005</b>	4485	4135
<b>GBA 61006</b>	4420	4070
<b>GBA 85004</b>	5000	4600
<b>GBA 85005</b>	4885	4485
<b>GBA 85006</b>	4875	4475
<b>GBA 110005</b>	9385	8485
<b>GBA 110006</b>	9375	8475
<b>GBA 130005</b>	9730	8830
<b>GBA 130006</b>	9365	8665

	CC
<b>CC30</b>	35
<b>CC120</b>	50
<b>CC350</b>	90
<b>CC600</b>	135
<b>CC1000</b>	350



